

CRYOPUMP CRYO-U[®] SERIES Instruction Manual

CRYO-U[®]20BLM

Export Control Policy

Vacuum pumps that pump nitrogen gas at pumping speed of 15000L/s or more fall under row 2(35) of appended table 1 of Japan's Export Trade Control Order, which is based on international export control regimes. Also, when applying a refrigerator system to a cryocooler for optical sensors, the cryocooler falls under row 10(2) of appended table 1 of Japan's Export Trade Control Order as well.

Customers must follow all related rules and regulations such as Foreign Exchange and Foreign Trade Act and take appropriate procedures when exporting or re-exporting those products.

Introduction

Thank you for choosing our products. This instruction manual gives information and precautions on handling, installation, operation, and maintenance of the product.

This product is intended for use by qualified personnel who recognize shock hazards and are familiar with the safety precautions required to avoid possible injury. To ensure proper use of this product, read this instruction manual carefully and keep this manual close at hand so that you can use for reference during operation.

If you purchased our other products and/or optional devices with this product, read relevant instruction manuals carefully.

1. About the personnel who are involved in handling our products

All personnel involved in handling our products should take a general safety education and training that is officially accepted in the country where our product is used. The personnel are also required to have specialized knowledge/skills and qualification on the electricity, the machinery, the cargo handling, and the vacuum. Especially, the personnel should be familiar with handling a cryopump in order to use it safely. Since we offer a training session (which is subject to fees) as needed for people who use cryopumps for the first time, please do not hesitate to contact our Service Engineering Division to join the training session.

2. Warranty

2.1 Gratis warranty period and Warranty coverage

【Gratis warranty period】

Note that an installation period of less than one year after installation in your company or your customer's premises or a period of less than 18 months (counted from the date of production) after shipment from our company, which is shorter, is selected.

【Coverage】

(1) Failure diagnosis

As a general rule, diagnosis of failure should be done on site by customer.

However, ULVAC CRYOGENICS or our service network can perform this service for an agreed fee upon the customer's request. There will be no charge if the cause

of the breakdown is found to be a fault of ULVAC CRYOGENICS.

(2) Damage during transportation

When damage by delivery/transportation is admitted, the product will be repaired free of charge within the range of the guarantee expressed in the sales contract.

(3) Breakdown repairs

There will be a charge for breakdown repairs, replacements and on-site visits for the following seven conditions. In those cases the cost shall be your own expense even though the product is within the warranty period.

- ① Breakdowns due to improper storage or handling, careless accident, software or hardware design by the customer.
- ② Breakdowns due to modifications of the product without consent of the manufacturer.
- ③ Breakdowns due to maintenance of the product without authentic parts or breakdowns resulting from using the product outside the specified specifications of the product.
- ④ Breakdowns due to contamination or corrosion caused by user's use conditions.
- ⑤ Breakdowns due to natural disasters (such as fire, earthquake, flood, lightning, salt damage, and so on) , environmental pollution, irregular voltage, and /or usage of undesignated power source.
- ⑥ Breakdowns that are outside the terms of warranty.
- ⑦ Consumables and/or replacement service.

Since the above services are limited to within Japan, diagnosis of failures, etc are not performed abroad. If you desire the after service abroad, please contact ULVAC CRYOGENICS and consult us for details in advance.

2.2 Exclusion of opportunity loss from warranty liability

Regardless of the gratis warranty term, compensation to opportunity losses incurred to your company or your customers by failures of ULVAC CRYOGENICS products and compensation for damages to products other than ULVAC CRYOGENICS products and other services are not covered under warranty.

2.3 Repair period after production is discontinued

ULVAC CRYOGENICS shall accept product repairs for seven years after production of the product is discontinued.

3. Service Form

After the products are delivered, please fill out the following information in the blanks. If you have any questions or technical problems, please feel free to contact the nearest Customer Support Center or headquarters. Please refer to "Service Network".

Cryopump/Super trap Model	:	_____
Cryopump/Super trap Serial No.	:	_____
Refrigerator Model	:	_____
Refrigerator Serial No.	:	_____
Compressor Model	:	_____
Compressor Serial No.	:	_____
Temperature controller/Thermal display Model	:	_____
Temperature controller/Thermal display Serial No.	:	_____
Option Part Model	:	_____
Optional Part Serial No.	:	_____

4. Notes for repair and maintenance requests

We may decline your request for the repair or the maintenance of our products if you refuse to give us information about the presence of the hazardous substance and/or contaminant.

Also, please be aware that we do not accept liability for damages by the contaminant, which might be caused during transportation to our office or the nearest customer support center. To avoid such accident, please pay careful attention to packing of the product

5. In case of breakdown and accident

When breakdown or accident occurs, we may ask for keeping the product on site as it is or retrieving the product to investigate its cause. Also we may ask for reporting the detailed process and/or the operating condition. When unidentified malfunction was generated, please contact our Service Engineering Division or

the nearest customer support center with reference to the chapter of Service Network. We ask for cooperation about the above.

6. General Precautions

- (1) It is strictly prohibited to duplicate, open, and transfer this instruction manual or any of its parts to a third person without written permission from ULVAC CRYOGENICS.
- (2) Information in this document might be revised without a previous notice for the specification change and the improvement of the product.
- (3) If you have any questions or comments on this document, please do not hesitate to contact us. The phone numbers of local customer support centers are listed at the end of this manual.

Safety Considerations

Our products have been designed to provide extremely safe and dependable operation when properly used. Following safety precautions must be observed during normal operation and when servicing them.

**WARNING**

A warning describes safety hazards or unsafe practices which could result in severe injury or loss of life.

**CAUTION**

A caution describes safety hazards or unsafe practices which could result in personal injury or equipment damage.

**Toxic gas or chemicals used.**

There is a risk of severe injury upon contact.

**Corrosive chemicals used.**

There is a risk of severe injury upon contact.

**Flammable gas used.**

There is a danger of fire or burn injury.

**Explosive gas used.**

There is a risk of fire or explosion.

**Hazardous voltage .**

Electric shock may cause severe injury or loss of life.

**Hot heating part present.**

There is a risk of burn injury.

This page intentionally left blank

TABLE OF CONTENTS

Safety Instructions	S-1
Disposal Consideration	IW-1
SECTION 1 Cryopump Description	
1.1 The General.....	1-1
1.2 Specifications.....	1-2
1.3 Environmental Requirements	1-3
SECTION 2 Inspection	
2.1 Shipping List.....	2-1
2.2 First Inspection of Cryopump	2-2
SECTION 3 Quick Installation	3-1
SECTION 4 Installation	
4.1 Auxiliary Equipments Required	4-1
4.2 Mounting Cryopump to Vacuum System	4-3
4.3 Connecting Roughing Pump	4-5
4.4 Connecting Purge Gas Line	4-5
4.5 Connecting Exhaust Pipe	4-6
4.6 Connecting Cooling Water Pipe	4-7
4.7 Laying Flexible Hoses.....	4-7
4.8 Connecting Cryopump and Compressor Unit	4-9
4.9 Connecting Remote Wiring	4-9
4.10 Connecting Electrical Cables	4-10
SECTION 5 Operation	
5.1 Prior to Startup	5-1
5.2 Rough Pumping.....	5-1
5.3 Pressure Buildup Test	5-2
5.4 Startup and Cooldown.....	5-2
5.5 Normal Operation.....	5-3
5.6 Crossover	5-4
5.7 Shutdown Procedures.....	5-5

5.8 Handling of Hazardous Materials 5-6

SECTION 6 Regeneration

6.1 The General 6-1
 6.2 Regeneration Time 6-2
 6.3 Warm-up Method 6-2
 6.4 Regeneration Flow Chart 6-4

SECTION 7 Disconnecting and Storage

7.1 Disconnecting Flexible Hose 7-1
 7.2 Storage 7-2

SECTION 8 Maintenance

8.1 Scheduled and Unscheduled Maintenance 8-1
 8.2 Consumables 8-3
 8.3 Cleaning the Cryopump 8-4
 8.4 Charging Helium Gas 8-5
 8.5 Helium Circuit Decontamination 8-8

APPENDICES

A. Troubleshooting A-1
 B. Flexible Hose B-1
 C. Conversion of Thermometer Readings C-1
 D. Principle of Cryopump Operation D-1
 E. Principle of Refrigerator Operation E-1
 F. Dew Condensation F-1

Service Network CS-1

FIGURES

Figure	1-1 Typical CRYO-U® Cryopump System	1-1
	1-2 External Drawing of CRYO-U® Cryopump	1-3
	1-3 Major Components	1-4
	3-1 Quick Installation Process Flow	3-2
	4-1 Example of CRYO-U® Cryopump Vacuum System.....	4-2
	4-2 Examples of Cryopump Installation.....	4-3
	4-3 Maintenance Space	4-4
	4-4 Pressure Loss of Regeneration Gas Purge PR Unit	4-6
	4-5 Laying Flexible Hoses	4-8
	4-6 Connecting Flexible Hoses	4-11
	7-1 Disconnecting Flexible Hose.....	7-2
	8-1 Charging Helium Gas	8-7
	8-2 Disconnecting Flexible Hose.....	8-9
	8-3 Connecting Charging Adapter	8-9
	8-4 Cryopump Decontamination Procedures (1)	8-10
	8-5 Cryopump Decontamination Procedures (2)	8-12
	8-6 Connecting Flexible Hoses	8-13
	D-1 Vapor Pressure of Various Kinds of Gas.....	D-2
	E-1 Principle of Refrigeration.....	E-1
	E-2 Principle of G-M Cycle Operation.....	E-4
	E-3 Two-stage Refrigerator	E-4

TABLES

Table	1-1 CRYO-U® Specifications.....	1-2
	2-1 Shipping List for Cryopump System.....	2-1
	2-2 Shipping List for Cryopump assembly	2-1
	3-1 Quick Installation	3-1
	4-1 Laying Flexible Hoses	4-8
	5-1 Cryopump Temperature Indication (When used at room temp.of 20°C)	5-3
	5-2 Maximum Quantity of Sucked Gas Processable by Cryopump (Guideline Quantity to the Air).....	5-5
	8-1 Maintenance Parts and Intervals	8-2
	8-2 CRYO-U® U20BLM Consumables	8-3

A-1 Cryopump Fault Diagnosis	A-2
A-2 Operating Log	A-7

Safety Instructions

The following precautions contain information regarding to safety of handling CRYO-U® Cryopump. For employing it correctly and safely, please read these precautions carefully and fully understand them before designing and setting up your entire pumping system with the cryopump.

1. Pressure Relief Valve



A cryopump captures gases and vapors by condensing them on a cryogenic surface within the vacuum chamber. In the warm-up process during regeneration, the captured gases vaporize again and the pressure inside the cryopump rises. The pressure changes depending on the kinds and the amounts of the gases captured, as well as the size of the cryopump. For example, when Argon is pumped to its pumping capacity shown in the catalog while the cryopump is sealed up, the pressure inside the cryopump becomes several MPaG. To prevent main valve failure, CRYO-U® cryopump is equipped with a pressure relief valve which releases this pressure rise.

The spring of the pressure relief valve opens when the internal pressure exceeds the set pressure between 10 and 20kPaG. The outlet of pressure relief valve must not be closed. In addition, never attempt to strengthen the spring of pressure relief valve, nor use a pressure relief valve for other purposes such as a roughing port or a gauge port as it is extremely dangerous.

For handling the pressure relief valve, take notice to the following matters as well;

- **While the pressure relief valve is working, dust in the cryopump may cause a leakage by sticking to the valve sheet. Clean the valve each time if used under the condition that the pressure relief valve works during regeneration. In addition, remove and clean the valve regularly to prevent sticking of O-ring even when used under the condition the valve does not work.**
- **When pumping toxic or flammable gases, the quantity of captured gas should be monitored and controlled to prevent the pressure relief valve from working during regeneration. Also, it is required to install an exhaust duct which is connected to the pressure relief valve in order to process the gases safely. If the use of such toxic or flammable gases is planned, please consult with us as necessary.**

KF25 flange is attached to the pressure relief valve for installing a duct.

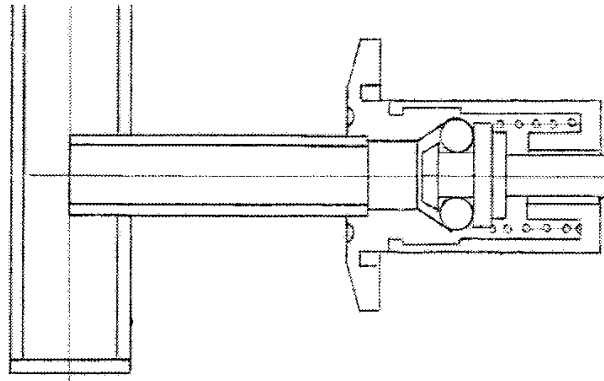

Figure 1 Pressure Relief Valve (from ULVAC CRYOGENICS)

2. Check the safety of secondary-generated gases in process



Some gases are generated in vacuum processes as by-products. They may include flammable, oxidizing, explosive, or toxic gases.

For example, water in vacuum chamber, which comes from the atmosphere or the substrate, dissociates into hydrogen and oxygen in plasma. Those gases may be also discharged in large volume from some vapor or sputter materials. **Oxygen is one of the gases which helps combustion, hydrogen is flammable and explosive.** At atmospheric pressure, the mixed gas with hydrogen of 4% or more and oxygen of 5% or more cause explosion momentarily if there is an ignition (refer to “2.Do not pump flammable or explosive gases”).

In addition, ozone might be secondarily generated when oxygen (O₂) or carbon dioxide (CO₂) is resolved in plasma. Ozone is a toxic gas, and liquefied ozone is extremely unstable and when in high density it may explode by reacting with organic substances or any impact.

It is necessary to check the safety of the secondarily generated gases as well as gases to be introduced in the vacuum chamber.

For handling flammable or explosive gases, refer to “4.When pumping flammable or explosive gases” and “5.When pumping oxygen” in this chapter. Implement safety precaution and preventive maintenance as necessary.

For handling toxic gases, specific safety measures to the gas may have to be taken as well as the safety precautions for flammable or explosive gases. For example, purge of pump or dilution of exhaust duct with inert gas corresponds to it.

Customers are requested to take safety measures for cryopump operation appropriate for the equipment or processes.

Table 1 Combustion range and detonation range of major gases
(Volume percentage against air)

Gas		Molecular Weight	Specific Gravity 0°C, 1atm	Boiling Point K	Combustion Range Vol. %	Detonation Range Vol. %
Hydrogen	H ₂	2.016	0.070	20.3	4.0-75.0	18.3- 59
Carbon Monoxide	CO	28.01	0.970	81.7	12.5-74.0	
Hydrogen Sulfide	H ₂ S	34.08	1.190	213.6	4.3-45.0	
Silane*	SiH ₄	32.14	1.107	161.2	0.8-98	
Arsine*	AsH ₃	77.94	2.692	210.7	0.8-98	
Phosphine*	PH ₃	34.00	1.146	185.5	1.3-98	
Diborane*	B ₂ H ₆	27.67	0.955	180.7	0.8-98	
Ammonium	NH ₃	17.03	0.590	239.8	15-28	
Methane	CH ₄	16.04	0.555	111.6	5.3-14	
Ethane	C ₂ H ₆	30.07	1.040	184.6	3.0-12.5	
Propane	C ₃ H ₈	44.10	1.550	231.1	2.2-9.5	
Etylene	C ₂ H ₄	28.05	0.978	169.5	3.1-32	
Acetylene	C ₂ H ₂	26.04	0.907	198.2	2.5-100	4.2- 50

(*): Hikaru Harada; "Handotai-gas Anzen-ka Souran 1st Edition" (The 1st edition of Semiconductor gas safing comprehensive manual) published by Science Forum Inc. 1984
Except (*): The high pressure gas safety institute of Japan; "Koatsu-gas Kogyo Gijyutu" (High pressure gas industrial technology) published by Kyoritsu Shuppan Co., Ltd. 1977

Table 2 Combustion range and detonation range of mixture of oxygen and flammable gas

Gas	Combustion Range (Vol. %)	Detonation Range (Vol. %)
Hydrogen	4 - 94	15 - 90
Acetylene	2.3 - 94.5	3.5 - 93
Methane	5.1 - 61	-
Propane	2.3 - 55	3.7 - 37
Carbon Monoxide	15.5 - 94	38 - 90
Ammonium	15 - 79	25.4 - 75

The high pressure gas safety institute of Japan; "Koatsu-gas Kogyo Gijyutu" (High pressure gas industrial technology) published by Kyoritsu Shuppan Co., Ltd. 1977

3. Perform regeneration immediately after shutting down cryopump



After shutting down the cryopump operation, proceed with warm-up and rough pumping as part of regeneration process in order to maintain the cryopump in clean vacuum.

In many vacuum pumping processes, large amount of moisture is often captured and condensed inside the cryopump. If the cryopump is left without appropriate care after shutdown, captured moisture will react with internal parts, resulting in corrosion. Moreover, if corrosion of internal parts continues, pumping performance may deteriorate resulting in extended cooling time or rise of ultimate temperature.

Make sure to perform regeneration immediately after shutting down the cryopump in order to remove water vapor. Following three steps in the regeneration sequence mentioned in Section 6.4 are required; 1) Warm-up, 2) Discharge (desorption) of captured gas, and 3) Pressure buildup check.

Such corrosion of inner kits might occur depending on the kind or amount of the process gases. Also, note that when the inner kits need to be replaced due to corrosion, such service should be paid even within the guaranteed term.

4. Cautions when pumping flammable or explosive gases



Hydrogen has both flammability and explosiveness. When a flammable or explosive gas is pumped with the cryopump, it must be removed safely from the pump in the warm-up process of regeneration. Be sure to take the following safety precautions.

- (1). Control and manage the process condition, the time period and method of regeneration in order to keep the concentration of the hazardous gases discharged to the exhaust duct below an allowable value.
- (2). Eliminate ignition factors completely from the pump and duct.
- (3). Make sure that the safety precautions mentioned above can work well even in any abnormal events.

Possible causes of ignition in the vacuum equipment are as follows:

- Ignition by a vacuum gauge filament being turned on
- Ignition by a heater with heating element(s) exposed into the process circumstance or the like

- Ignition by static electricity
- Ignition by liquid ozone

If a roughing pipe or exhaust line is made of plastic such as vinyl chloride, it may produce static electricity.

On the other hand, ozone may generate under the process utilizing plasma with oxygen or CO_x gas. Captured and condensed ozone in the pump liquefies in the warm-up process of regeneration. Note here is the following. The liquid ozone is so unstable that it might explode by impact or ignition resulting from the reaction with organic matter.

In case of a pumping flammable or explosive gas(es), appropriate safety precaution must be taken with reference to “6. Regeneration after pumping flammable, explosive, or combustion enhancing gas”.

5. When pumping oxygen



Mixing oxygen and flammable gas invites danger.

Oxygen enhances combustion. Use the cryopump after confirming the safety precautions or measures when pumping the mixture of oxygen and flammable gas into the cryopump. In particular, mixed gas of oxygen and hydrogen has a broad range of combustion/detonation and is extremely dangerous.

The mixed gas with hydrogen of 4% or more and oxygen of 5% or more at atmospheric pressure could cause explosion momentarily (refer to “4. When pumping flammable or explosive gases”).

When oxygen is used as a process gas, appropriate safety precautions must be taken with reference to “6. Regeneration after pumping flammable, explosive, or combustion enhancing gas”.

Oxygen may generate ozone.

Ozone may be unexpectedly generated in plasma production process (e.g., sputtering, etching, glow discharge, EB deposition). Ozone pumped and condensed in the cryopump liquefies in the warm-up process of regeneration. The liquid ozone at high concentrations might explode by impact or ignition by the reaction with organic matter. In case that large amount of ozone is generated in the process and accumulated in the cryopump, following may be observed at the time of regeneration:

- (1) Cracking/popping sounds (as in electrical arcing) is heard in the first few minutes of regeneration.

- (2) Gases exhausted from cryopump have pungent odor, similar to that produced in arc welding operation.

Large volume of ozone may invite an intense explosion. If ozone has been pumped with the cryopump, the following safety precautions must be taken.

1. Perform regeneration more frequently to minimize the amount of ozone captured in the cryopump. Required frequency varies depending on the oxygen flow rate or other process conditions.
2. Minimize the flow rate of oxygen gas to the extent it does not affect the process.
3. Make sure the safety again when the process is changed, as it might bring increase in ozone generation.

When using oxygen as a process gas, appropriate safety precaution and measures must be taken with reference to “6. Regeneration after pumping flammable, explosive, or combustion enhancing gas”.

6. Regeneration after pumping flammable, explosive, or combustion enhancing gas



When regenerating the cryopump after pumping flammable, explosive, or oxidizing gases, those gases must be safely vaporized again and exhausted. Following safety measures on the regeneration method are extremely important for employing the cryopump safely. Please take proper safety measures with both hardware and software. Also, note that such hazardous gases may be produced as by-product in the vacuum chamber as a result of plasma reaction.

1. Safety measures for regeneration

Following are the safety measures that customers are required to supply and implement regarding regeneration process after pumping flammable, explosive, or oxidizing gases. Refer to Figure 2 and take necessary measures. You may have to take additional safety measures depending on the kind of the gas used, the process conditions, or the environment used. Be sure to take required and sufficient safety precautions according to actual conditions.

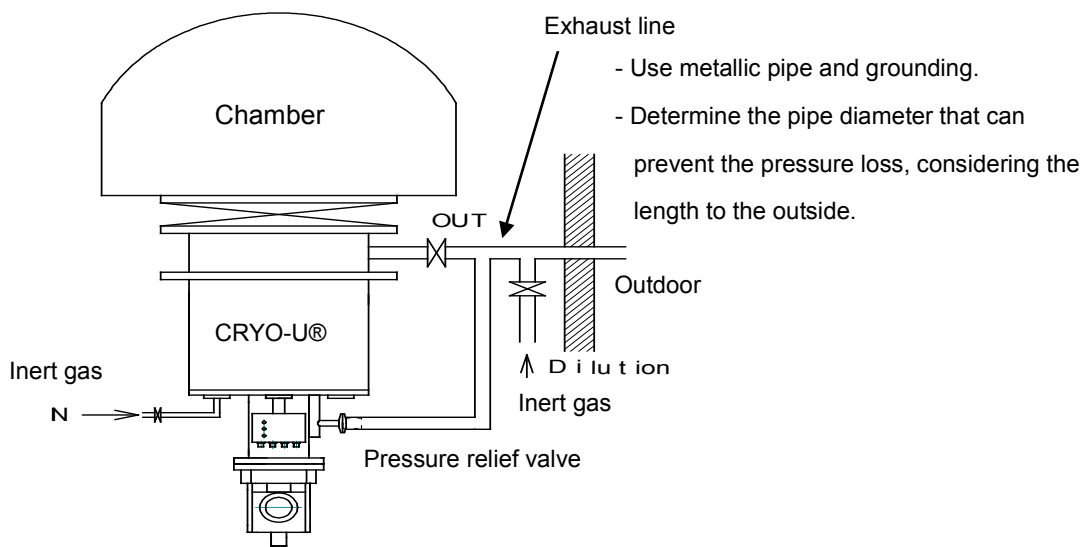

Figure 2 Dilution of Oxygen/Flammable Gas

- (1) Whenever a cryopump stops, it is required to perform assisted regeneration immediately to remove flammable, explosive or oxidizing gases from the cryopump regardless of the cause of shutdown. Use nitrogen gas with dew point temperature of below -40°C or argon as the inert gas. (In this book, the terms “inert gas” or “dry nitrogen or argon” mean “nitrogen gas with dew point temperature of -40°C or below or argon”.)

Both the purge of the cryopump and the dilution of the exhaust duct with the inert gas are required to reduce the concentration of hazardous gas and keep it under a certain level where the gas does not burn or explode even when it evaporates during warm-up.

Fix the purge flow rate, dilution flow rate, and regeneration cycle (pumping capacity of flammable gas) and take necessary safety measures before starting cryopump operation.

- (2) When the above regeneration is delayed or is not conducted, all the gases captured in the cryopump will evaporate by natural temperature rise. If the volume of such gases is large, cryopump pressure may easily reach or exceed the atmospheric pressure. Note that a roughing pump should not be used to pump such hazardous gases remaining inside the cryopump as it may lead to gas explosion.

In order to exhaust the vaporized gases from the cryopump safely, make sure to purge the cryopump with inert gas before initiating vacuum pumping.

- (3) Eliminate ignition factor. Insure that there are no sources of ignition (refer to “4. When pumping flammable or explosive gases”) on the cryopump side during

regeneration.

- (4) Be sure to use metallic pipes for the roughing system and exhaust lines in order to prevent generation of static electricity. Ground the pipes with the grounding resistance of 100 Ω or less.
- (5) In case that the gas to be exhausted is hazardous and lighter than the dilution gas (such as hydrogen gas), design and install the exhaust pipes so that its lighter gas should not be accumulated in the pipes.
- (6) Perform inert gas purge into the exhaust line in order to reduce the flammable gas concentration below its combustion range before exhausting them away to atmosphere.
- (7) Perform inert gas purge as the regeneration starts.
- (8) Assuming the pressure relief valve would work, connect the pressure relief valve to the exhaust line in order to dilute the gases which might spout out from the valve.
- (9) Be sure not to rough pump the cryopump without inspecting the state of the pump just after power failure. As mentioned in the above ②, reduce the concentration of hazardous gases in the pump and exhaust line by adding inert gas before rough pumping. It helps to exhaust the vaporized gas safely out of the pump in case power failure occurred.
- (10) When adopting an oil-sealed rotary pump as a roughing pump, change lubricating oils with Fomblin grease which is insensitive to oxygen. Instead, a drypump will be fully recommended.

2. Safety measures in emergency

If troubles such as blackout, water outage, or pneumatic abeyance cause suspension of a cryopump, take either among the following two actions.

- 1) When the cause of failure is eliminated before the temperature of the 2nd stage reaches 20K, restart the cryopump.
- 2) When the temperature of the 2nd stage exceeds 20K, perform regeneration even if the cause is eliminated. It is necessary to prepare some adequate devices to introduce an inert gas automatically into both the cryopump and exhaust duct. The devices include a thermometer, a valve for purge inert gas to the cryopump, a valve for exhausting gases from the cryopump, an atmospheric pressure sensor in the cryopump and a valve for introducing dilution gas into the exhaust line.

UPS (Uninterruptible Power Supply system) installation

In case that the cryopump stops because of blackout etc, hydrogen explosion or high-temperature combustion which must occur if high concentration of O₂ or H₂ is

filled up in the pump with some source(s) of ignition such as O₃.

UPS is necessary to prevent those hazards described in both cases of 1) and 2) above.

7. Rupture of refrigerator cylinder by corrosion



The cylinder of refrigerator is mainly made of stainless steel and copper.

Special precautions must be taken when pumping corrosive gas which may be produced by plasma reaction, sputtering, etc. in chamber, and corrodes cylinder materials.

For maximizing performance of the refrigerator, the stainless steel cylinder thickness is very thin. During normal operation, the pressure of helium gas in the refrigerator is approximately 2 - 2.5 MPaG and if the corrosion develops, the cylinder may rupture at weak portion.

- If the cryopump is used to pump corrosive gases, periodic pressure proof test is recommended.
- ULVAC CRYOGENICS INC. conducts the pressure proof test of the cylinder by increasing the gas pressure to 1.5 times as high as the operating pressure.

It is strongly advised to handle corrosive substances with sufficient caution to the toxicity and danger.

8. Assembly and disassembly of refrigerator



The refrigerator contains high-pressure and high-pure helium gas. When disassembling your refrigerator, please contact our Service Engineering Division or the nearest customer support center for technical assistance.

If you will perform maintenance or disassembly of the refrigerator by yourself, take the following special precautions for maintenance or disassembly of the refrigerator.

1. Exhaust helium gas completely from self-sealing couplings on both helium return and supply flexible hoses by using the charging adapter.
2. Make sure that the helium gas pressure has fallen on 0 MPaG and then loosen the bolts.

NOTE: Do not loosen all the fixed components such as bolts, plugs, and pressure relief valve pointed by arrows in Figure 3 before discharging the helium gas. Ignoring this note may cause severe injury or equipment damage by flying components due to residual pressure.

Take the following cautions when assembling the refrigerator by yourself.

1. Tighten the bolts of each part in the diagonal sequentially.
2. Because the heavy load of the high-pressure helium gas is applied, torque management for tightening the bolts up is important. As for cylinder bolts (M5 × 6pcs) used in the refrigerators of R10 to R50 series, the required torque is 6.9N·m (70kgf·cm). On the other hand, as for cylinder bolts (M6 × 6pcs) used in the refrigerators of R80 series, it is 11.6N·m (118kgf·cm).
3. Fill the refrigerator with the helium gas slowly confirming that there is no defect or abnormality.
4. When adding the helium gas, please follow the all instructions described in “8.4 Cryopump Decontamination Procedures” in this manual.

Ensure that the bolts are securely tightened. Loosened bolts or bolts tighten under the regulation torque may cause severe injury or equipment damage.

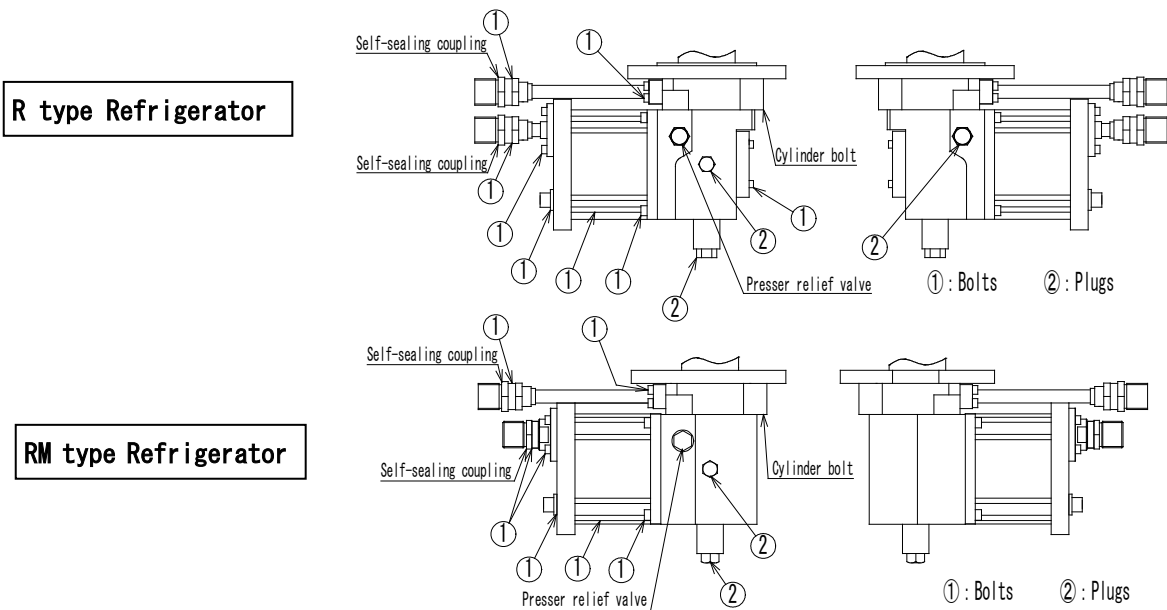

Figure 3 Bolt Locations

9. Do not charge the system with excessive helium gas



The refrigeration system in our cryopump systems circulates high-pressure helium gas to generate refrigeration cycle. Charging the system with helium gas more than appropriate value does not enhance the performance of refrigerator. Conversely, if helium gas pressure exceeds the specified level, the pressure relief valve may work, resulting in leakage caused by particles stuck in the vacuum seal in the valve. In addition, some compressor units activate pressure sensor which may lead to disabling cryopump operation.

Do not charge the system with helium gas exceeding the appropriate volume.

10. Power source of cryopump system



Refer to the instruction manual of the compressor unit to be utilized with the cryopump, and confirm the power source required for the system.

(1) Make sure to connect the earth wire to a ground terminal.

Earth : D-class grounding with the ground resistance of 100 Ω or less.

(2) Install ground-fault interrupter on the electric supply line for the compressor unit.

(3) Do not connect any devices except a cryopump system on the outlet of the ground-fault interrupter.

11. Contact us immediately when the self-sealing coupling is loosened.



When working with a self-sealing coupling, the connection may be accidentally loosened or loosened by co-rotation. In such cases, the refrigerator may encounter faults due to helium leakage or air invasion, resulting in serious failure such as abnormal noise or refrigerator motor malfunction.

At the time of shipment of our products, we conduct the inspection to ensure the connection of self-sealing coupling is appropriate and paste a sealing sticker. The sealing stickers are added to our refrigerators, compressor units, flexible hoses, branch pipes and straight pipe units.

Contact us when the self-sealing coupling is loosened or removed. Servicing for trouble is out of warranty if it occurs while the sealing sticker is not in the original state.

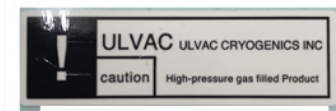
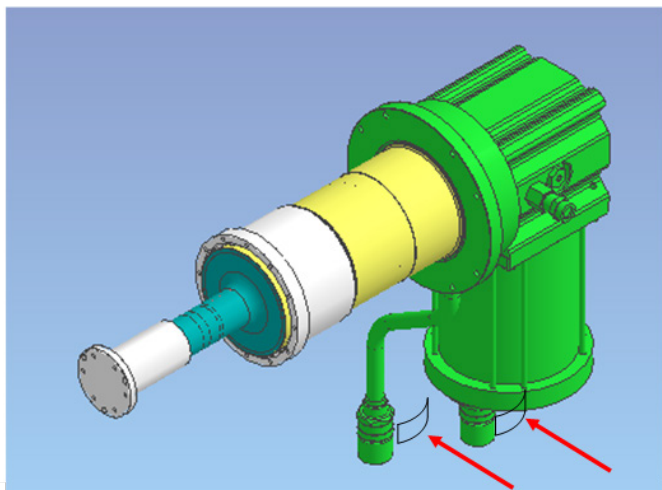

Sealing sticker

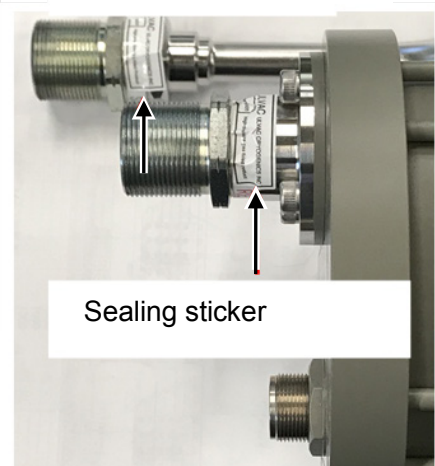

Figure 4 Examples of the sealing stickers

Disposal Considerations

Disposal of our products must be done in accordance with applicable national and local laws and regulations.

				WARNING
<p>The cryopumps or cryocoolers may contain residue of hazardous substances resulting from actual use. Contact your safety supervisor and follow the instructions to remove such toxic substances before disposing.</p>				

We provide Safety Data Sheet (SDS) of our products upon your request.
Please contact us if necessary.

This page intentionally left blank.

1. CRYOPUMP DESCRIPTION

1.1	The General	1-1
1.2	Specifications.....	1-2
1.3	Environmental Requirements.....	1-3

1.1 The General

CRYO-U® cryopump system condenses and adsorbs gas molecules on its cryogenic surface to capture and pump gases.

Our cryopumps can pump most gases rapidly in wide pressure range, yielding clean high and ultra-high vacuum.

This cryopump system employs two-stage closed cycle compact cryocooler cooled by helium gas to achieve ultra-low temperature surfaces of below 20K and below 80K, providing continuous operation for long hours with simple operation.

As shown in Figure 1-1, the cryopump system consists of a cryopump assembly (including refrigerator unit), a compressor unit, flexible hoses, and several cables.

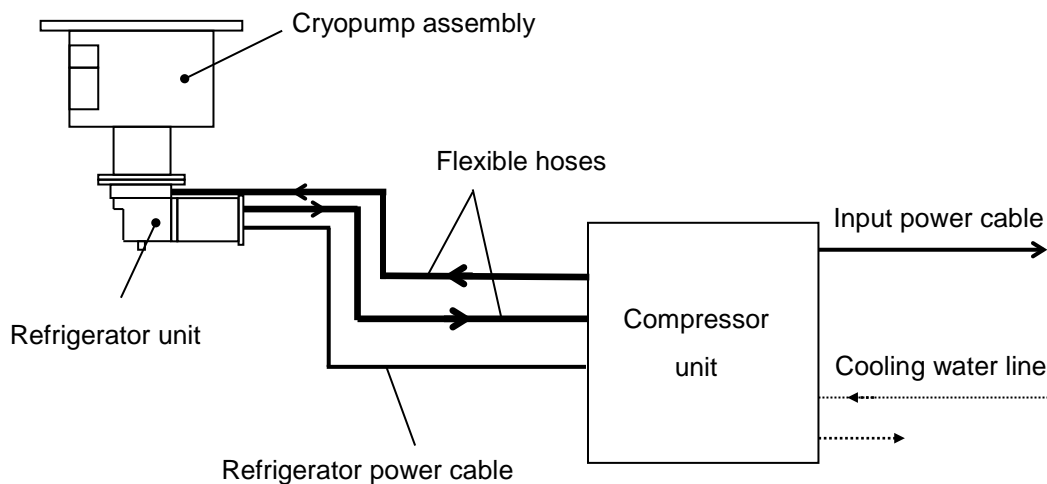

Figure 1-1 Typical CRYO-U® Cryopump System

1.2 Specifications

Table 1-1 CRYO-U® Specifications

		U20BLM (*1)
Pumping speed (L/s)		
	Nitrogen	10,500
	Hydrogen	14,000
	Argon	8,700
	Water	29,000
Ultimate pressure (Pa)		The order of 10^{-7}
Maximum throughput (Pa·L/s)	Argon	1.6×10^3
Pumping capacity (Pa·L)	Argon	5.8×10^8
	Hydrogen	4.6×10^6
Cool-down time (min)		200/180 (50Hz/60Hz)
Weight (kg) (*2)		100
Refrigerator unit		RM120ET
Compressor unit		C30HMVRT
Flexible hose		20A
Helium gas supply and return connectors		1/2B self-sealing couplings
Mounting orientation		Any (*3)

(*1) CRYO-U20BLM is designed for multiple operation.

Normally, run two units of CRYO-U20BLM at the same time.

It is safe to run single unit with power supply frequency of 50Hz, but with 60Hz, the compressor is overloaded, resulting in reduction of life.

Please contact us if you wish to run single unit with power supply frequency of 60Hz.

(*2) This is the weight of standard cryopump. The weight varies depending on customer's specifications.

(*3) Mounting orientation may be limited depending on the type or volume of gases to be captured.

1.3 Environmental Requirements

Table 1-2 Environmental Specifications

Condition	Requirement
Temperature when in operation(*1)	10 - 35 °C
Temperature when not in operation	-10 - 55 °C
Humidity (*1)	5 - 85% (non-condensing)
Altitude	< 1000m
Atmosphere	Free from metallic powder, dust, combustible gas, or corrosive gas

(*1) Depending on the ambient temperature and humidity, dew condensation may form on an operating cryopump as the surface of the pump case becomes colder than the dew-point (Refer to "Appendix F Dew Point Temperature"). Use an air conditioner to control temperature and humidity to prevent condensation.

◆ Thermometer

MBS-C CRYO METER

◆ Dimensions

The figures below show basic external dimensions of our cryopump. If any additional information is required, please contact us.

※ Mounting locations of optional parts such as thermometer or accessory flange may vary according to your request.

NOTE: UVG flange is equivalent to VG of JIS standard.

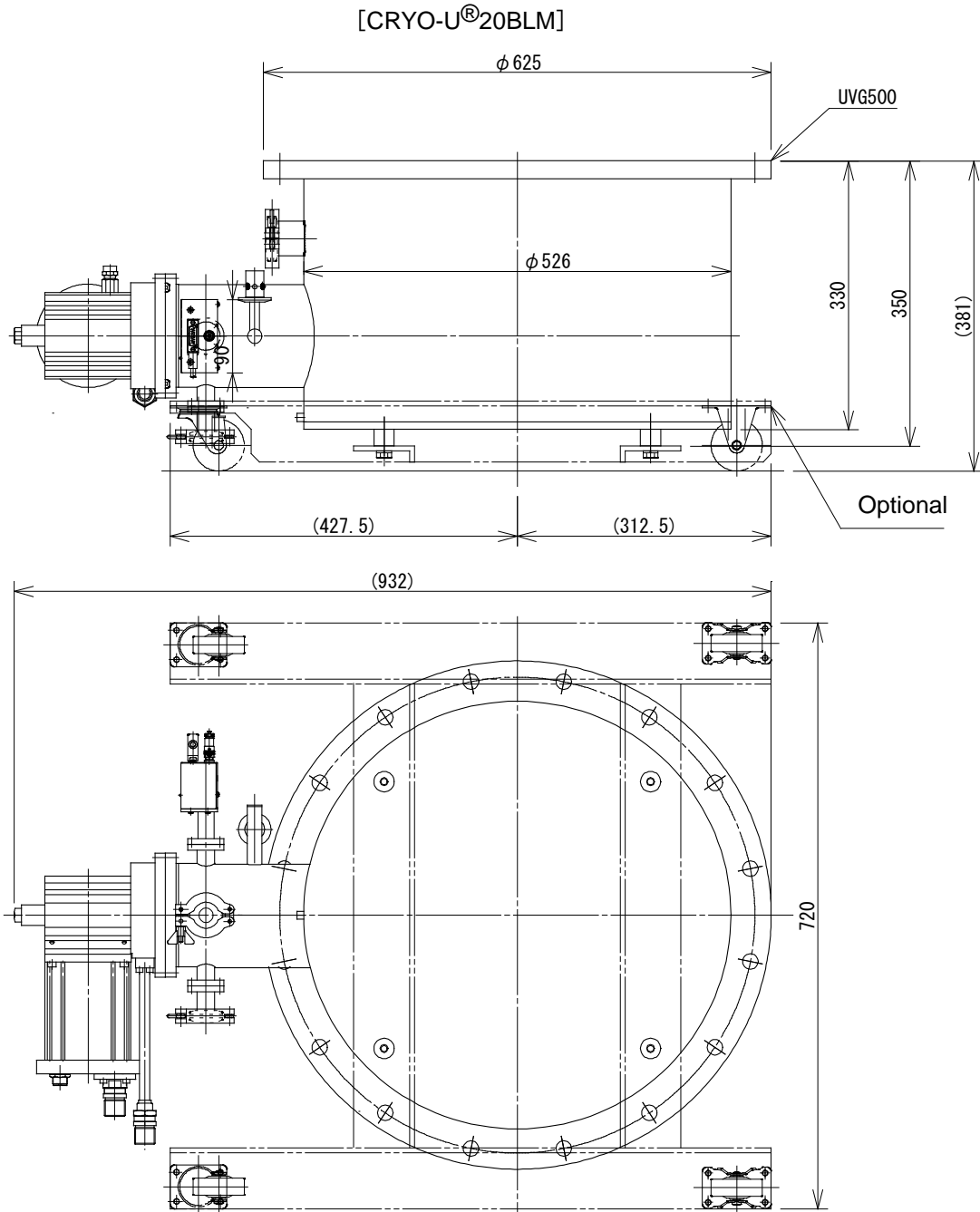
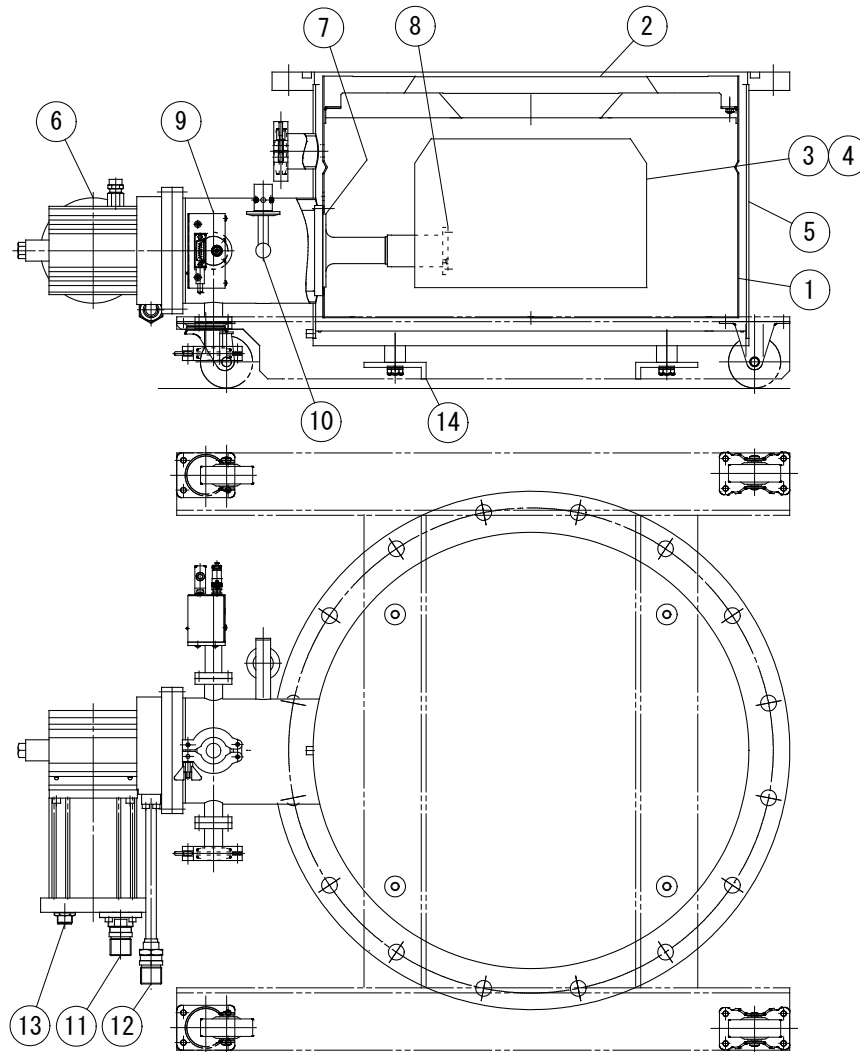

Figure 1-2 External Drawing of CRYO-U[®] Cryopump (Unit:mm)

* The following drawings show the outline of the structure and may differ from actual ones.

[CRYO-U®20BLM]



Inner kit①~④

- | | | |
|---|--------------------|--------------------------------------|
| ①80K shield | ⑤Pump case | ⑩Pressure relief valve |
| ②80K baffle | ⑥Refrigerator unit | ⑪Helium gas return connector |
| ③15K cryopanel(1)
(Condensation panel) | ⑦1st stage | ⑫Helium gas supply connector |
| ④15K cryopanel(2)
(Adsorption panel) | ⑧2nd stage | ⑬Refrigerator power supply connector |
| | ⑨MBS-C CRYO METER | ⑭Traveling base (Optional) |

Figure 1-3 Major Components

This page intentionally left blank.

2. INSPECTION

2.1	Shipping List	2-1
2.2	First Inspection of Cryopump	2-2

2.1 Shipping List

When the cryopump system is delivered, make sure that there is no damage or shortage of delivered items by checking the external view of the package and the shipping list attached.

Please see Table 2-1 if you purchased a CRYO-U® cryopump system, and Table 2-2 for CRYO-U® cryopump assembly alone.

Please read the enclosed cover letter for the details.

Table 2-1. Shipping List for Cryopump System

Item	Quantity
CRYO-U® cryopump	1
Compressor unit	1
Accessory of compressor unit ^{(*)1}	1
Optional devices for control system ^{(*)2}	1
Instruction manual <ul style="list-style-type: none"> ▪ This instruction manual ▪ Instruction manual of optional devices for cryopump ^{(*)3} ▪ Instruction manual of compressor unit ▪ Instruction manual of optional devices for control system 	1 each
^{(*)1} Input Power Cable, Refrigerator Power Cable, Remote Connector, Spanner kit, Flexible Hose, etc. Contents of accessories depend on the model of your compressor unit. Read the compressor unit instruction manual for the details ^{(*)2} CRYO-METER, Heater Controller, Diode Indicator, or the cables etc. Read the cover letter for the details. ^{(*)3} MBS-C CRYO-METER, RBH Band Heater, Regeneration Gas Purge PR Unit, etc.	

Table 2-2. Shipping List for Cryopump assembly

Item	Quantity
CRYO-U® cryopump	1
Instruction manual <ul style="list-style-type: none"> ▪ This instruction manual ▪ Instruction manual of optional devices for cryopump ^{(*)3} 	1 each
^{(*)3} MBS-C CRYO-METER, RBH Band Heater, Regeneration Gas Purge PR Unit, etc.	

2.2 First Inspection of Cryopump

Open the shipping carton and conduct the following.

1. Confirm there is neither damage nor a dent in externals and accessories of the pump, and is moreover no missing parts.
2. Remove the protective cover and confirm that there is no damage in the mounting flange or 80K baffle. (After the inspection, the protective cover should be put on again until the time of installation.)
3. Notice to "Hydrogen Vapor Pressure Gauge" users:
Make sure that the charge pressure shows 0.35 ± 0.02 MPaG at room temperature. The pressure depends on the room temperature. If it is lower than 0.3 MPaG in ambient temperature range of $20^{\circ}\text{C} \pm 10^{\circ}\text{C}$, there is a possibility of hydrogen leakage or defects of the pressure gauge.
4. For optional devices such as MBS-C CRYO-METER, please refer to instruction manuals of each device for more information.



If you find any missing parts or damages of the product, please contact our Service Engineering Division or the nearest Customer Support Center.

3. QUICK INSTALLATION

This section provides simple installation procedures for users who are already familiar with cryopump installation and operation.

If more details are required, please refer to the explanation of each section shown in the table below.

Table 3-1. Quick Installation

Steps	Procedures	For Details
	<div style="border: 2px solid black; padding: 5px;"> <div style="display: flex; justify-content: space-between; align-items: center;"> <div style="text-align: center;">  </div> <div style="text-align: center;">  WARNING </div> </div> <p>◆ Do not connect the compressor unit to its power source before the following installation processes finish.</p> </div>	
1	Mount the cryopump to the vacuum system.	Section 4.2
2	Connect the roughing system, regeneration gas purge unit, and exhaust duct line to the cryopump.	Section 4.3, 4.4 and 4.5
3	Connect the cooling water piping to the compressor unit.	Section 4.6
4	Connect the cryopump to the compressor unit with flexible hoses.	Section 4.7
5	In case of remote operation, remote wiring is necessary.	Section 4.8
6	Connect the refrigerator power cable from the cryopump to the compressor unit.	Section 4.9
7	Connect the input power cable from the compressor unit to its power source.	Section 4.9
8	Start the cryopump system according to the procedure described in "Section 5 Operation".	Section 5

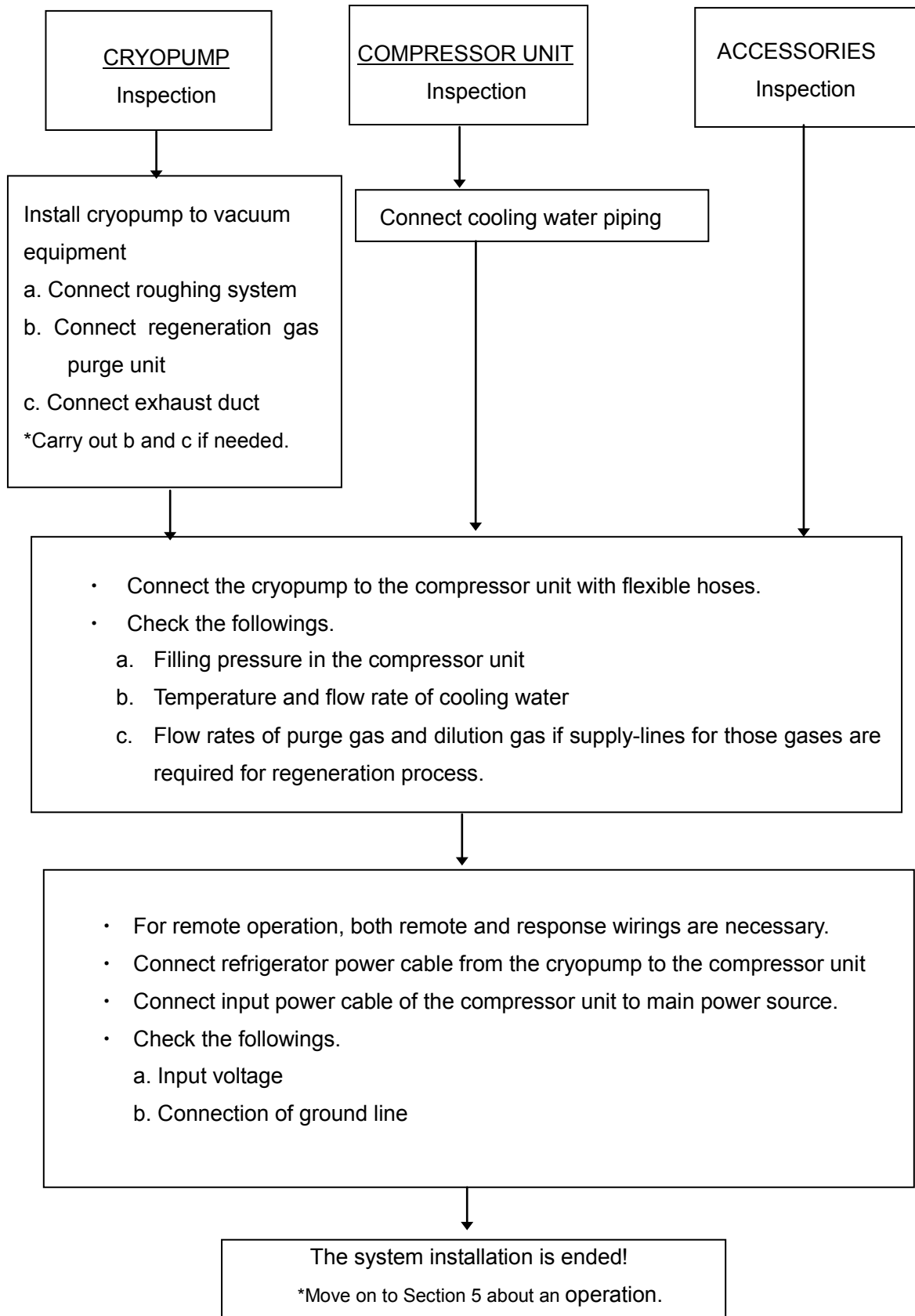

Figure 3-1. Quick Installation Process Flow

4. INSTALLATION

4.1	Auxiliary Equipments Required	4-1
4.2	Mounting Cryopump to Vacuum System	4-3
4.3	Connecting Roughing Pump	4-5
4.4	Connecting Purge Gas Line	4-5
4.5	Connecting Exhaust Pipe	4-7
4.6	Connecting Cooling Water Pipe	4-7
4.7	Laying Flexible Hoses	4-7
4.8	Connecting Cryopump and Compressor Unit	4-9
4.9	Connecting Remote Wiring	4-10
4.10	Connecting Electrical Cables	4-10

4.1 Auxiliary Equipment Required

For operating CRYO-U® cryopump system, following auxiliary devices are required.

- ◆ Roughing pump : Used to rough pump cryopumps or exhaust the gases released in the cryopump during regeneration process. A roughing pump system with a mechanical booster pump, which can rough pump the cryopump to 1Pa or less, is recommended.
- ◆ Roughing valve : Used to isolate the cryopump from the roughing pump during cryopump operation.
- ◆ Vacuum gauge for rough pumping
: Used to monitor the pressure during rough pumping and regeneration. Scale range: Atmospheric pressure - 1Pa.
- ◆ Vacuum gauge for high-vacuum pumping
: Used to monitor the pressure during cryopump operation. Ionization gauge is recommended. Scale range: 10^{-1} - 10^{-6} Pa
- ◆ Main valve : Used to isolate the vacuum chamber from the cryopump. The valve with large conductance, such as a gate valve, clapper valve, L-type valve and so on, are normally used.

< To prevent back stream of rotary pump oil >

If it would be concerned that the rotary pump oil might flow backward by rough pumping for a long time, the following measures are recommended:

- Insert a fore-line trap into the roughing line
- Adopt a drypump as the roughing pump

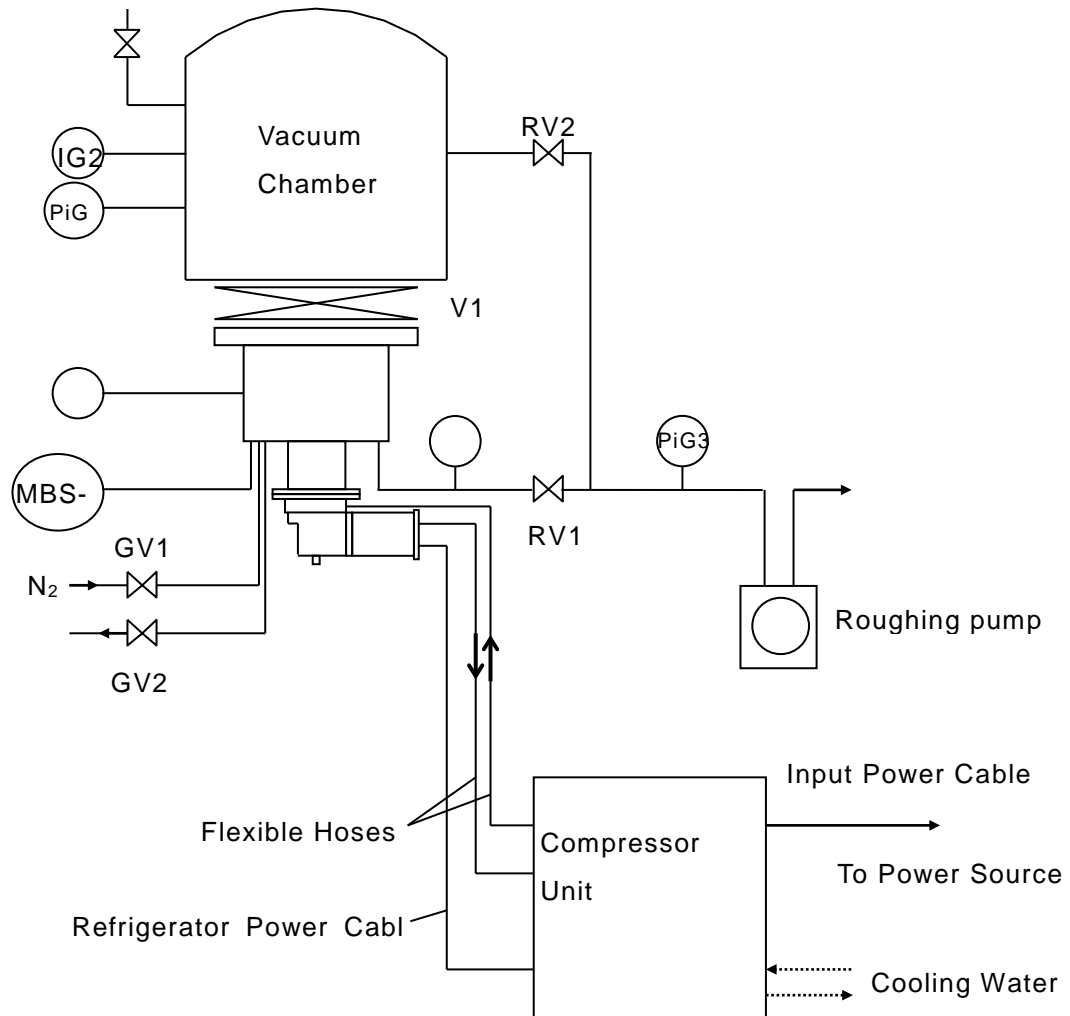

MBS-C : MBS-C CRYO METER

* Select a thermometer according to the model of your cryopump.

PiG1 : CRYOPUMP PIRANI GAUGE

IG1 : CRYOPUMP IONIZATION GAUGE

PiG2 : VACUUM CHAMBER PIRANI GAUGE

IG2 : VACUUM CHAMBER IONIZATION GAUGE

PiG3 : ROUGHING PUMP PIRANI GAUGE

V1 : MAIN VALVE

RV1 : CRYOPUMP ROUGHING VALVE

RV2 : VACUUM CHAMBER ROUGHING VALVE

GV1 * : PURGE GAS INTRODUCTION VALVE (if required)

GV2 * : PURGE GAS EXHAUST VALVE (if required)

* Refer to Section 4.4 for more details.

Figure 4-1 Example of CRYO-U® Cryopump Vacuum System

4.2 Mounting Cryopump to Vacuum System

- Our cryopumps may be installed in any orientation. However, the performance may slightly change depending on the mounting orientation (see Table 1-1 in Section 1.2).
- If the vacuum chamber has any heat source, install cryopump not to face directly to the heat source. Refer to Figure 4-2.
- Install cryopumps considering maintenance. Refer to Figure 4-3 for the recommended maintenance space for cryopump.
- Install the main valve between the cryopump and the vacuum chamber.
 1. Remove the protective cover from the cryopump.
 2. Clean the surface of the flange and insert O-ring or metal gasket.
 3. Mount the cryopump to main valve (or the vacuum chamber.)
 4. Make sure that all bolts are fastened tight enough.

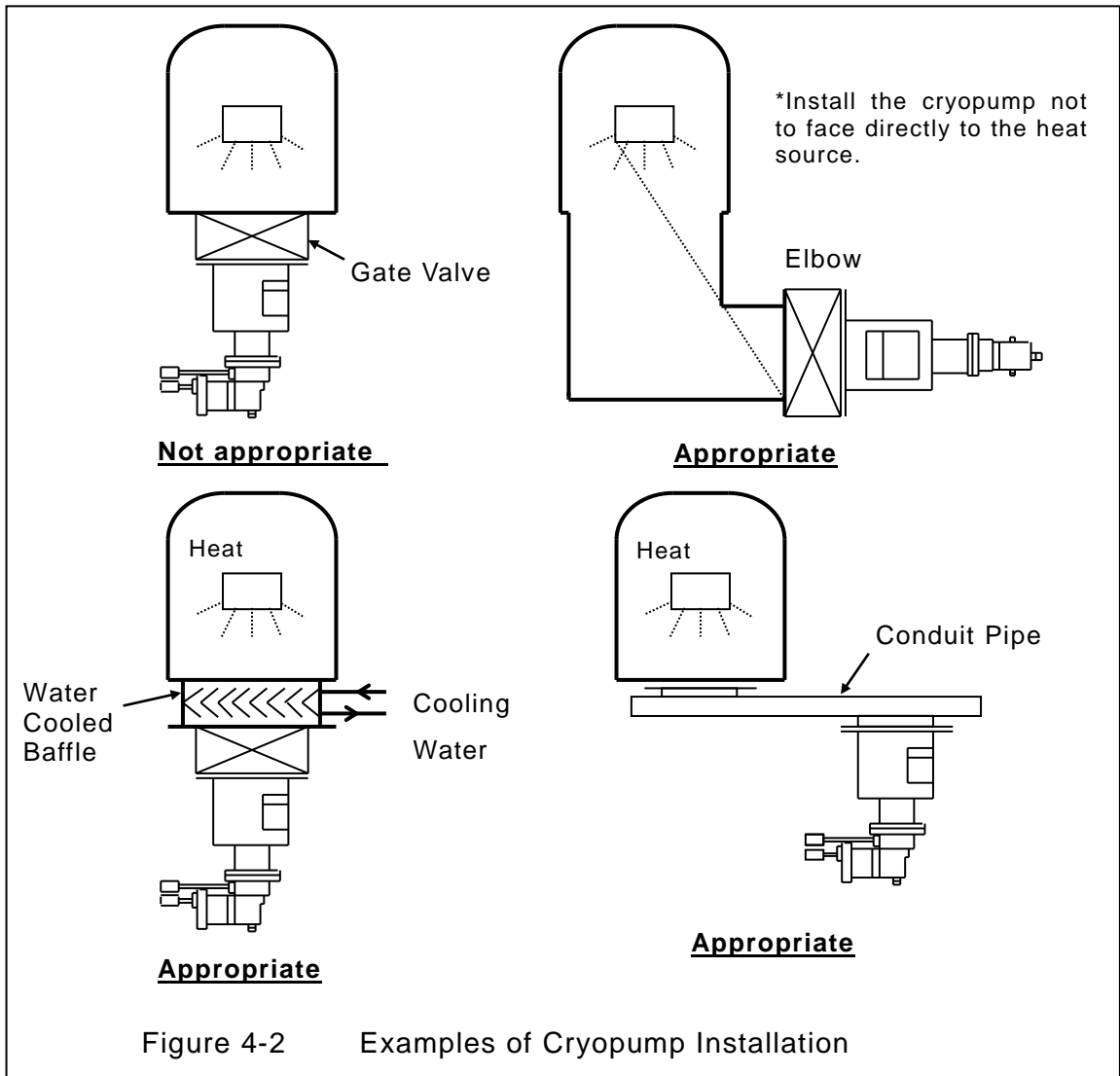

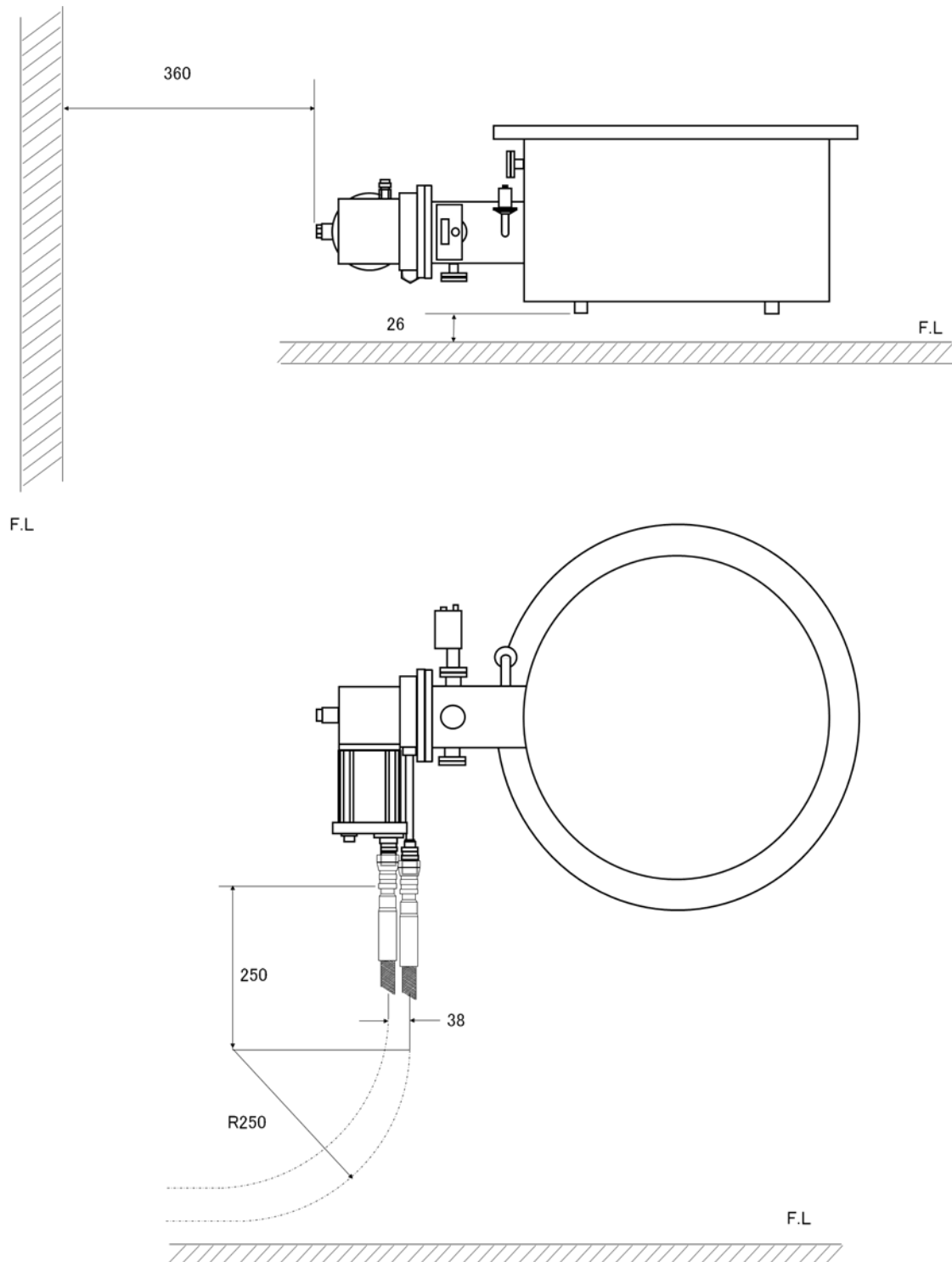

* This shows the minimal maintenance space required for a refrigerator unit with cryopump attached to the customers' system.

Figure 4-3 Maintenance Space

4.3 Connecting Roughing Pump

1. Connect roughing pump system to the cryopump accessory port or the manifold between cryopump and main valve. The roughing time can be shortened by using wider pipes.
2. Install a pirani gauge between cryopump and roughing pump. It is recommended to install it close to the cryopump.
3. Addition of a foreline trap in the roughing line is recommended in order to prevent the cryopump from back stream of oil when rough pumping to 40Pa or less by oil-sealed rotary pump. Regenerate the fore-line trap on a regular basis.

4.4 Connecting Purge Gas Line

Connect the gas purge line to the cryopump accessory port referring to Section 1.2, if needed for regeneration. Use nitrogen gas that its dew point temperature is -40°C or below or argon as the purge gas. Set its flow rate and supply pressure as follows;

Flow rate ^(*) : in the range from 20NL/min to 50NL/min

Supply pressure: 10kPaG or less

^(*) Larger flow rate may be demanded when pumping flammable gas or oxygen gas into the cryopump. Design and construct the flow pathway of the purge gas carefully to ensure the required flow rate.

In case of using our optional Regeneration Gas Purge PR Unit ^(*) ^(*), (not applicable for a certain type of cryopump), choose an appropriate size and length of the gas purge pipe in order to maintain the pressure loss in the entire purge gas introduction line to be 5kPaG or less at the set flow rate. (Refer to Figure 4-4 Pressure Loss of Regeneration Gas Purge PR Unit ΔP_{pr} .)

^(*) Regeneration Gas Purge PR Unit is an all-in-one unit equipped with Purge Gas Introduction Valve, Purge Gas Exhaust Valve, and Atmospheric Sensor, which makes it easier to connect gas purge pipe and exhaust pipe. It is also space-saving. The unit comes in three different types which are PR-1A, PR-2A, or PR-3A. Choose applicable type for your cryopump. Read the Regeneration Gas Purge PR Unit instruction manual for more details.

(*3) When regenerating flammable or oxygen gas, the inlet for purge gas and the outlet from the cryopump should be separated and be set up. In this case, our Regeneration Gas Purge PR Unit should not be used. Please design and construct the purge gas inlet and outlet lines so that dangerous gases can be smoothly exhausted.

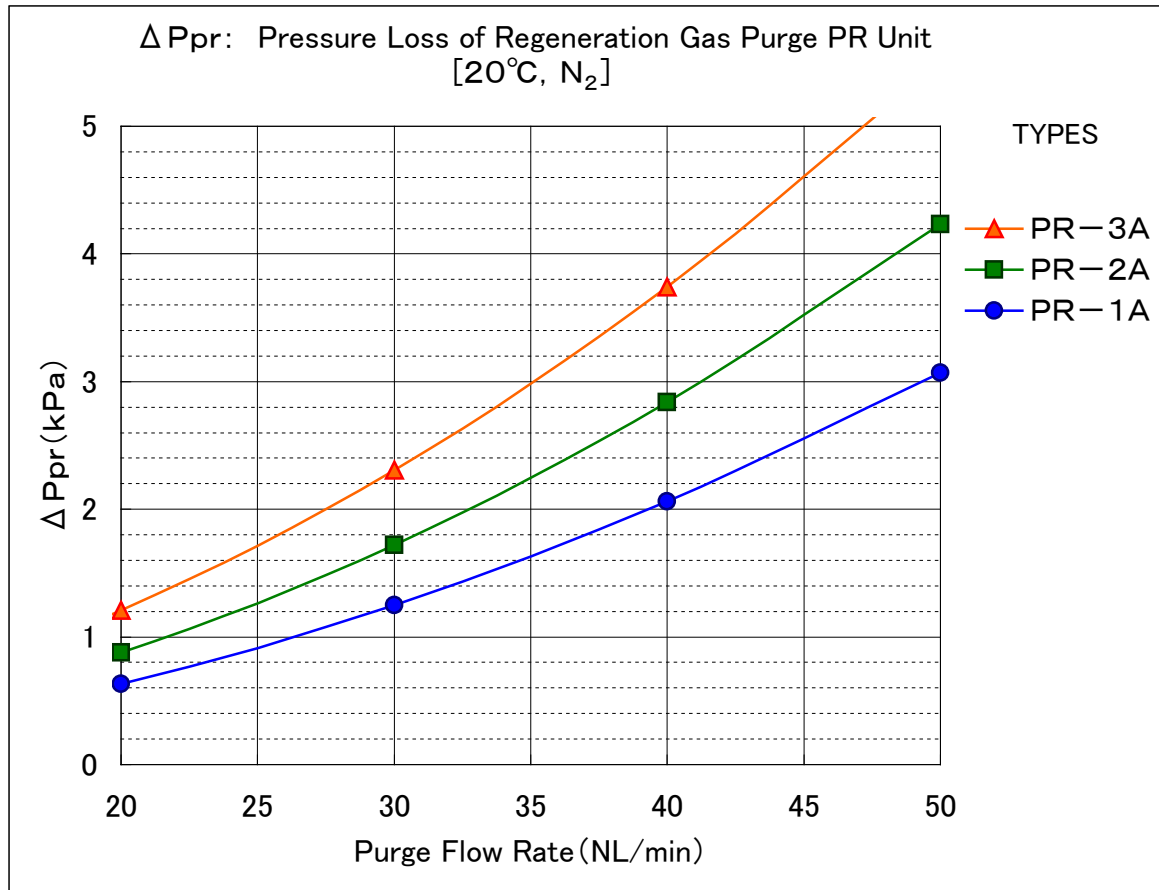







Figure 4-4 Pressure Loss of Regeneration Gas Purge PR Unit

4.5 Connecting Exhaust Pipe

					 WARNING
<p>◆ Toxic, corrosive, flammable, or explosive gases has to be vented to a safe place through exhaust pipe. In such cases, an exhaust pipe must also be connected to the cryopump pressure relief valve.</p> <p>◆ Do not block the pressure relief valve. See “Safety Instructions” for details.</p>					

CRYO-U® Cryopump pressure relief valve has KF25 flange to connect the exhaust pipe.

4.6 Connecting Cooling Water Pipe

 CAUTION
Observe the cooling water requirement described in the compressor unit instruction manual.

1. Connect the cooling water pipe to the compressor unit. The connector thread for both “COOLING WATER IN” and “COOLING WATER OUT” is Rc 3/8 female.
2. Use cautions to connect the cooling water pipes to inlet and outlet ports correctly.
3. Run cooling water with the actual flow conditions, and make sure that there is no water leakage.

Please read the compressor unit instruction manual for more information on the connecting method or the requirements for water pressure and flow rate.

4.7 Laying Flexible Hoses

 CAUTION
If flexible hoses are connected in an inappropriate manner, the compressor may be overloaded while in operation, resulting in reduction of life. Refer to the following procedure for connecting flexible hoses.

Follow the procedures below depending on the distance between compressor and cryopumps.

(a): Flexible hoses diverge from the connection ports with manifolds and are connected in parallel.

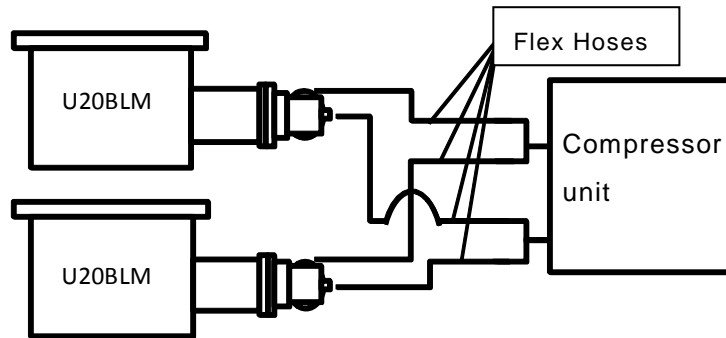

(b): Flexible hoses diverge from the middle with manifolds.

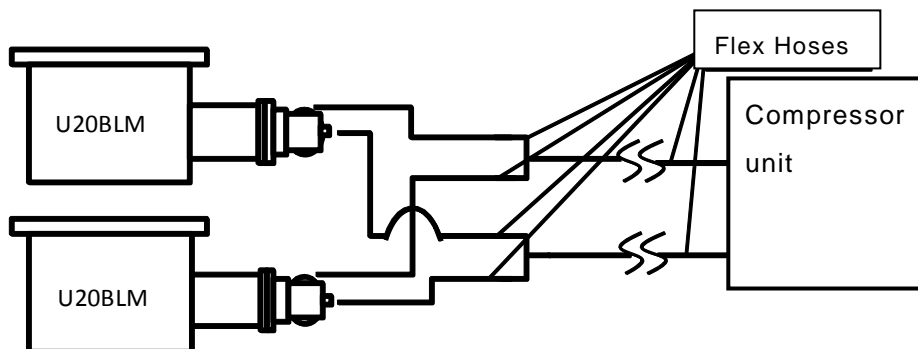

Figure 4-5 Laying flexible hoses

Table 4-1 Laying flexible hoses

Distance between cryopump and compressor	Connection	Note
Less than 10m	(a)	-
Longer than 10m	(b)	Parallel connection from manifolds should be less than 10m

4.8 Connecting Cryopump and Compressor Unit



CAUTION

- Use 20A flexible hoses. The CRYO-U22BLM cannot achieve the expected performance with 15A hose which is normally used for our other cryopumps.
- Read the handling notes in appendix B about the connection of the flexible hoses.
- When connecting flexible hoses, always use two single open end spanners with width across flat 26mm and 30mm.
- Do not forcibly bend flexible hoses. They may be damaged and cause helium leakage.
- Do not connect or disconnect self-sealing coupling frequently. It may cause gas leakage. Replacement with new one might be needed depending on the occurrence of leakage.

1. Remove all dust plugs and caps from supply and return flexible hoses, compressor unit and cryopump. Clean flat rubber gaskets on the self-sealing couplings to be free from dust or metallic powder.
2. Connect the flexible hoses between the compressor unit and the cryopump as follows (see Figure 4-5):
 - a. Connect one end of the "SUPPLY" labeled flexible hose to the helium-gas SUPPLY connector on the compressor unit, and connect the other end of the hose to the SUPPLY connector of the cryopump.
 - b. Connect one end of the "RETURN" labeled flexible hose to the helium-gas RETURN connector on the compressor unit, and connect the other end of the hose to the RETURN connector of the cryopump.
3. Check helium gas pressure on the compressor unit. If the pressure is higher than appropriate, release helium gas by opening the gas charge valve **slowly**. If the pressure is lower than appropriate, charge helium gas as described in Section 8.4 in this manual.

4.9 Connecting Remote Wiring

For remote operation, a remote wiring is necessary.

Please read the compressor unit instruction manual for the electric machine design specification concerning the remote operation.

4.10 Connecting Electrical Cables

	 WARNING
Connect the power supply cable of the compressor unit after all the other connections are made.	

1. Connect the refrigerator power cable from the compressor unit to the cryopump.
2. Connect the ground.
3. Connect the power supply cable from the compressor unit to its power source.
4. Refer to the compressor unit instruction manual for how to start up the compressor unit.

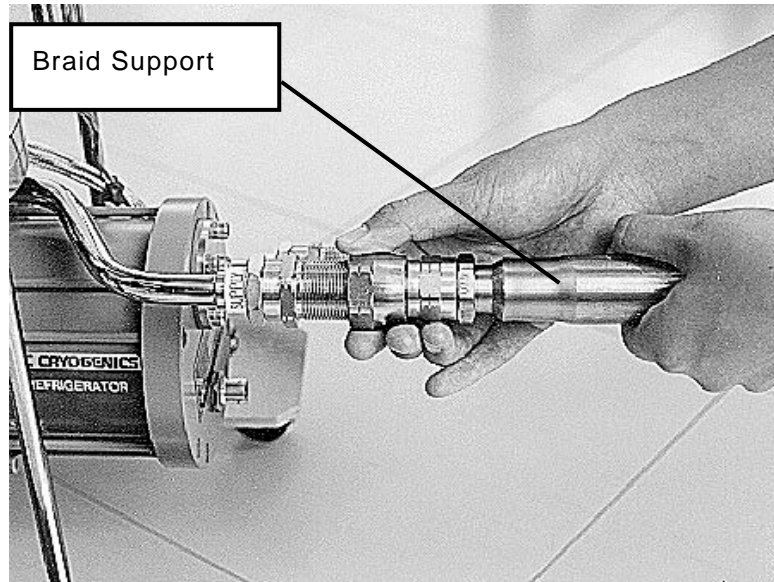

- ① Hold the braid support straight and tighten the self-sealing coupling by hand.

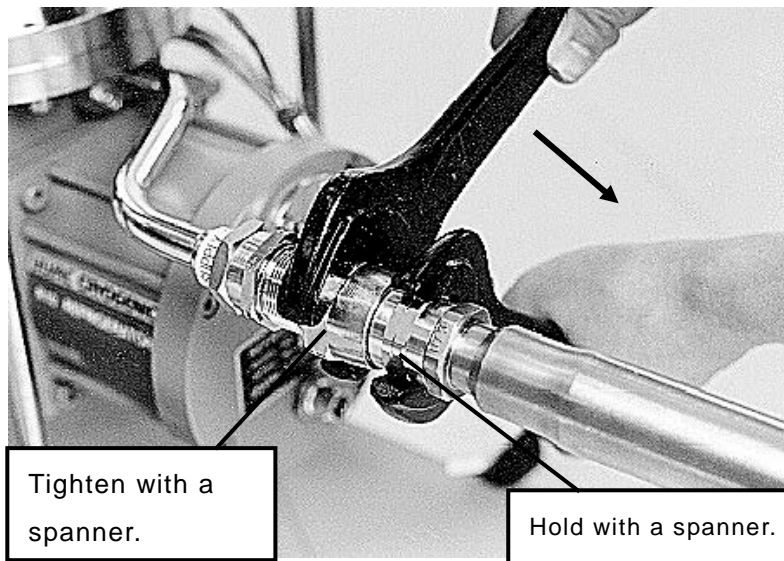

- ② Tighten the self-sealing coupling using two spanners **until the fittings are firmly sealed**. When using torque wrench, the recommended torque value is 20N·m.

Figure 4-6 Connecting Flexible Hoses

This page intentionally left blank

5. OPERATION

5.1	Prior to Startup	5-1
5.2	Rough Pumping.....	5-1
5.3	Pressure Buildup Test	5-2
5.4	Startup and Cooldown.....	5-2
5.5	Normal Operation	5-3
5.6	Crossover	5-4
5.7	Shutdown Procedures.....	5-5
5.8	Handling of Hazardous Materials.....	5-6

NOTE: The regeneration procedures described in this section is referring to a vacuum system shown in Figure 4-1 as an example.

5.1 Prior to Startup

Before starting operation, please check the followings:

1. The flexible hoses and cables are properly connected.
2. The gauges are mounted on each intended port.
3. The main valve (V1) is closed.
4. The roughing valves (RV1, RV2) are closed.
5. The helium charge pressure of the compressor unit is appropriate.

It is recommended to conduct daily check and keep operating log (See Appendix A) to find the first sign of a trouble in early stage. This will help you get prompt technical assistance from us. It also works out when troubles arise.

5.2 Rough Pumping

Before starting up, the cryopump needs to be rough pumped to approximately 40Pa. If pressure of 40Pa or lower is required, it is recommended to add a fore-line trap in the rough pumping system or use a dry pump instead of a oil-sealed rotary pump.

1. Start up the roughing pump.
2. Open the roughing valve (RV1) and rough pump the cryopump.

5.3 Pressure Buildup Test

1. When the pressure inside the cryopump reaches 40Pa, close the roughing valve (RV1) and check the pressure buildup.
If the pressure buildup stays less than 6.5Pa in five minutes, the roughing process has been completed. If it increased by 6.5Pa or more in five minutes, repeat the rough pumping procedure described in Section 5.2.
2. After the test has completed, rough pump the cryopump to 40Pa. Then close the roughing valves (RV1) and turn off the roughing pump.

5.4 Startup and Cooldown

1. Start up the compressor unit.

† For Your Information †

- Until the cooling process reaches the stable state, the rubbed sound is heard inside cold heads. When the stable state is reached, this sound become smaller, and the sound of inhaling or exhausting helium gas like choo-choo become louder instead.
- Cooldown time is longer by 20% if one cryopump is turned on later than another one than two cryopumps are turned on at the same time. It is recommended to turn on two cryopumps simultaneously.

2. When the 15K cryopanel is cooled to 20K or lower and the 80K shield is cooled to 130K or lower, the cryopump is ready to pump down. Refer to Table 1-1 for cooldown time of the cryopump. If MBS-C CRYO-METER is attached on your cryopump, the temperature of the 15K cryopanel is displayed as shown in Table 5-1. As MBS-C has the function by which the thermocouple electromotive force is output directly, the temperature of 80K shield can be measured with K thermocouple also. (Please refer to MBS-C instruction manual for more details.) When a 15K cryopanel is equipped with a hydrogen vapor pressure gauge and a K thermocouple is mounted on the 80K shield, the measurements are displayed as shown in table 5-1.

Table 5-1 Cryopump Temperature Indication (When used at room temp. of 20°C)

Thermometer		Suspended	No-load running
MBS-C CRYO METER (measures 15K cryopanel temp. with chromel-AuFe T.C.) (*1)	Indication (*1)	Red LED lights up	Green LED lights up
	Temperature	280K and more	Lights when 20K or lower
Hydrogen vapor pressure gauge (measures 15K cryopanel)	Indication	0.35±0.02MPaG	-0.09MPaG or lower
	Temperature	-	15K or lower
K thermocouple (measures 80K shield temp.)	Indication	0mV	-7.0mV or lower
	Temperature (*2)	293K	80K or lower

(*1) MBD CRYO-METER (optional) can display the temperature digitally.

(*2) The temperature of 80K shield refers to the temperature conversion table of the thermocouple electromotive force.



CAUTION

If a cryopump is cooled down at the higher vacuum pressure for a long time, the cryopump case may dew. It may cause short-circuit if an electrical device is put under the cryopump. Be careful about the operating condition of equipment, and surrounding safety.

† For Your Information †

In case the radiation heat load is high, or the partial pressure of helium, neon or hydrogen gas is 0.1Pa or more after rough pumping, the cooldown time will be prolonged.

- Record the cooldown time to reach 20K and the gas pressure of the compressor unit at 20K in your operating log.

5.5 Normal Operation

When cooldown is completed, the CRYO-U® cryopump system is able to pump inside the vacuum chamber. Follow the procedure below to start pumping. It is recommended to keep the operating log regularly.

- Make sure that the 15K cryopanel has reached 20K or lower and the 80K shield has reached 130K or lower. Then turn on the roughing pump and open the roughing valve (RV2).

2. When the pressure of vacuum chamber has reached 40Pa, close the roughing valve (RV2) and then turn off the roughing pump.

If you use an oil-sealed rotary pump as a roughing pump, and rough pumped for a long time at the pressure of 40Pa or less, it is recommended to add a fore-line trap in the rough pumping line.

To determine the crossover pressure, refer to Section 5.6.

3. Open the main valve (V1) for high vacuum pumping of the chamber by the cryopump.
4. When the pressure of the vacuum chamber has reached the required value, proceed with vacuum process such as deposition or sputtering. The time required to reach the intended pressure depends on the volume, contents, and the wall conditions of the chamber, etc.



CAUTION

If the abnormal rise of the pressure in the chamber breaks out during operation, the cryopump case may dew. It may cause short-circuit if an electrical device is put under the cryopump. Be careful about the operating condition of equipment, and surrounding safety.

5.6 Crossover

The pressure (roughing pressure) of the vacuum chamber immediately before opening the main valve for cryopumping the vacuum chamber after roughing is called the crossover pressure. The maximum allowable roughing pressure in this case is called the maximum allowable crossover pressure. The moment the main valve is opened, gases inside the vacuum chamber flows into the cryopump to be pumped, but when the flow rate of gases exceeds the limit, the cryopump cannot restore its pumping performance, resulting in temperature rise and release of the gases captured so far.

The maximum allowable crossover pressure is calculated as follows;

[Crossover Pressure Calculation]

$$\text{Maximum allowable crossover pressure (Pa)} \leq \frac{\text{Max. quantity of sucked gas instantaneously processable (Pa} \cdot \text{L)}}{\text{Volume of vacuum chamber (L)}}$$

The maximum quantity of sucked gas which is instantaneously processable is given by the limit value at which the cryopump can restore the pumping performance. Normally, a value which controls the cryopanel temperature not to exceed 20K is used as the maximum allowable crossover pressure.

The maximum quantity of sucked gas which is instantaneously processable varies with the heat load on the cryopump and the quantity of the gas condensed in the cryopump. (Refer to Table 5-2.)

Table 5-2 Maximum Quantity of Sucked Gas Processable by Cryopump
(Guideline Quantity to the Air)

Model	Maximum volume of sucked gas instantaneously processable (Pa·L) Maximum volume for the temperature of 20K or less
CRYO-U20BLM	66500

[Example] When U20BLM is used and the vacuum chamber volume is 100L, the maximum allowable crossover pressure is calculated as follows

$$\text{Maximum allowable crossover pressure (Pa)} \leq \frac{66500 \text{ (Pa} \cdot \text{L)}}{100 \text{ (L)}} = 665 \text{ Pa}$$

† For your information †

In order to restrict the stored quantity of gas and extend the regeneration cycle, it is recommended to control the actual crossover pressure to 40Pa or lower.

5.7 Shutdown Procedures

1. Close the main valve (V1).
2. Turn off the compressor unit and the refrigerator to exhaust gases in the cryopump in accordance with the regeneration procedures described in Section 6.
3. The cryopump reaches to suspended state as it returns to the room temperature.
4. If you continue to conduct inspection, replacement, or repair of the cryopump, turn off the main power supply and stop circulating cooling water before starting the work required.

Maintain cryopumps in good condition so that it can work any time when needed.



CAUTION

- ◆ After the cryopump is shut down, proceed with warm-up and rough pumping which are parts of regeneration process in order to maintain the cryopump in a clean vacuum.

Refer to Clause 3. Proceed with regeneration right after the cryopump is shut down in the "Safety Instructions" section.

5.8 Handling of Hazardous Materials



WARNING

- ◆ When pumping toxic, corrosive, combustible, or explosive gases, please be sure to take sufficient safety measures based on respectively required statute(s) and rule(s), and put it into effect under the user's responsibility.

In addition, be careful not to exceed atmospheric pressure with those gases during regeneration.

Please refer to Safety Instructions for these hazardous gases.

- ◆ When transporting the cryopump which has pumped the hazardous materials, please take appropriate disposal according to the regulation system of each area and a country.

6. REGENERATION

6.1	The General	6-1
6.2	Regeneration Time	6-2
6.3	Warm-up Method	6-2
6.4	Regeneration Flow Chart	6-4

6.1 The General

Regeneration is a process to make the cryopump recover to its early state of the pumping performance by releasing the condensed or absorbed gases out of the pump.

Regeneration consists of four operations such as warm-up, discharge (desorption) of the captured gas, pressure buildup check, and cool-down.



CAUTION

- ◆ After stopping the cryopump operation, proceed with warm-up and rough pumping which are parts of regeneration process in order to maintain the cryopump in a clean vacuum. Refer to Clause 3. Proceed with regeneration right after the cryopump stops in the Safety section.
- ◆ Do not block the pressure relief valve.
- ◆ Be careful of a burn when using a baking heater.



WARNING

- ◆ In case of regeneration after pumping flammable, explosive, or combustion enhancing gas, both the purge of the cryopump and the dilution of the exhaust duct with the inert gas are required in order to reduce the hazardous gas within the concentration where it does not burn or explode even if it evaporates during warm-up.
Refer to Paragraph 6.Regeneration after pumping flammable, explosive, or combustion enhancing gas in the Safety section.
- ◆ Regarding toxic, corrosive, or other dangerous gases, be sure to process them safely so as not to harm the human body etc. Refer to Section 5.8 Handling of Hazardous Materials for the details.

6.2 Regeneration Time

Regeneration is required when any of the following events occurs after the cryopump has been cooled down. In order to maintain the stable refrigeration performance, it is recommended to perform regeneration before these events occur. Especially when handling dangerous gases, perform regeneration regularly before these events occur.

- ① Temperature of 15K cryopanel : 20K or more
- ② Temperature of 80K shield : 130K or more
- ③ Ultimate pressure of the cryopump five minutes after closing the main valve
: 1.3×10^{-4} Pa or more
- ④ When the amount of pumped gases reaches the pumping capacity as shown in Table 1-1.
- ⑤ When the cryopump can not maintain the original performance

Note: For ① and ② above, temperature indicator(s) is(are) required.

6.3 Warm-up Method

There are three methods for warm-up.

◇ Unassisted warm-up

Switch off the cryopump and wait for the 80K shield, 80K baffle, and 15K cryopanel to warm up to room temperature naturally. If quantity of the gas captured in the cryopump is less than the volume of the cryopump and safety of the gas is proved, perform this process, "Unassisted warm-up".



CAUTION

If flammable gas, explosive gas, or combustion enhancing gas is pumped in the cryopump, be sure to treat the gas safely by diluting it with inert gas (nitrogen gas that its dew point temperature is -40°C or below or argon).

Refer to Paragraph 6.Regeneration after pumping flammable, explosive, or combustion enhancing gas in the Safety section.

◇ Assisted warm-up using inert gas

This is a heating method of which introduces inert gas (nitrogen that its dew point temperature is -40°C or below or argon) immediately after the cryopump has been stopped and make the temperature of the 80K shield, 80K baffle, and 15K cryopanel rise to room temperature. This enables more efficient regeneration compared to an unassisted warm-up in the following respects.

- Shortens the time period to warm up the 80K shield, 80K baffle, and 15K cryopanel to room temperature.
- Shortens the time period to check the pressure buildup, as the inert gas will reduce the amount of water adsorbed onto 15K cryopanel.

◇ Assisted warm-up using a heater

In addition to the method using inert gas described above, using an optional band heater or inner heater enables warm up time even shorter. (The band heater or inner heater is not applicable for certain types of cryopump.)

ULVAC CRYOGENICS INC. offers different types of standard band heaters such as RBH type and silicon rubber type. The RBH band heaters self control the temperature around $70 \sim 80^{\circ}\text{C}$. The silicon rubber heater turns its power ON/OFF by its thermostat setting. Please refer to the instruction manual of each heater that you use for more information.

When using an inner heater, make sure to control the temperature with our CRYO Heater Controller (optional) such as MBDI-H1 series. The warm-up completion temperature should be set at 300K both at the 1st and the 2nd stages. Refer to the controller instruction manual for more details.



CAUTION

Maximum allowable temperature of the refrigerator unit is 70°C . If you use a heater, make sure to control the heater temperature so that the temperature of the cold stages of the refrigerator does not exceed 70°C . If it exceeds 70°C , inside of the refrigerator may be damaged by the heat and a refrigerator replacement may be needed.

Our standard band heaters are self temperature control type so they can be used without any temperature control instrument. However, when using a heater other than our standard band heater, make sure to have a measure to keep the temperature lower than 70°C such as having a temperature controller, overheat alarm function, or by observing and controlling the energizing time.



WARNING

Since the temperature of the heater surface becomes very high, make sure to take necessary measures to prevent fire and burn injury and also display warnings to call attention for safety.

6.4 Regeneration Flow Chart

The following flow chart explains each regeneration method when using the unassisted warm-up and the assisted warm-up. The procedures described here are based on the CRYO-U® Cryopump Vacuum System shown in Figure 4-1.

◇ Regeneration through unassisted warm-up

I. Warm-up

Close the main valve (V1), then shut off the cryopump. The unassisted warm-up starts.

II. Discharge (desorption) of captured gas

Leave as it is until 80K shield, 80K baffle, and 15K cryopanel reach room temperature for exhausting the gas.

III. Pressure buildup check

Open the roughing valve (RV1) and rough pump the cryopump to 40Pa.

Then close the roughing valve (RV1) and check the buildup of pressure in the cryopump. If the pressure buildup value stayed less than 6.5Pa for five minutes, the check is completed.

If it increased 6.5Pa or more in five minutes, repeat the rough pumping procedures to 40 Pa and the pressure buildup check.

IV. Cool down

Open the roughing valve after the pressure buildup check. Then rough pump the cryopump to 40Pa.

After closing the roughing valve (RV1), start the cryopump. When the cryopump is cooled down to the prescribed temperature, the regeneration process is completed

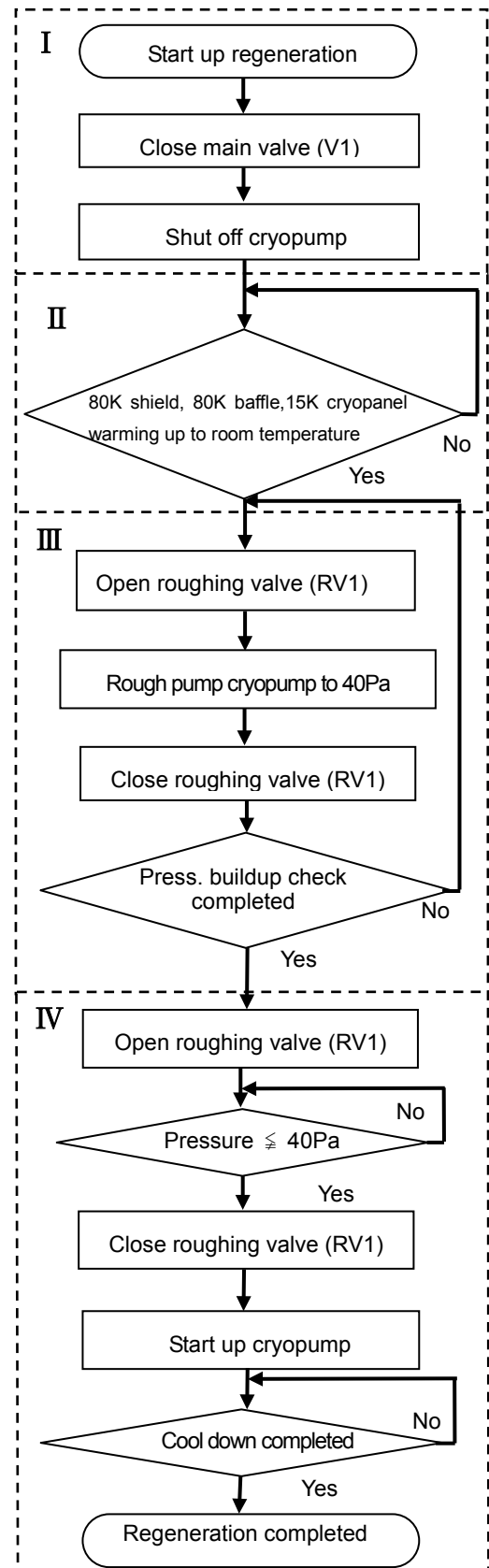

◇ **Regeneration through assisted warm-up**

I. Warm-up

Close the main valve (V1) and shut off the cryopump.

Then, open the purge gas introduction valve (GV1) to introduce the purge gas into the cryopump.

Power the heater (option) at the same time.

The assisted warm-up starts. Make sure the preset temperature of the heater is 300K.

II. Discharge (desorption) of captured gas

When the pressure inside of the cryopump reaches atmospheric pressure, open the purge gas exhaust valve (GV2) to exhaust the gas from the cryopump.

When the temperatures at 80K shield, 80K baffle and 15K cryopanel reach room temperature, close the purge gas introduction and exhaust valves (GV1, GV2).

NOTE: When flammable gas, explosive gas or oxygen is discharged, refer to Paragraph 6.Regeneration after pumping flammable, explosive, or combustion enhancing gas in the Safety section.

※¹ : The amount of gas captured in the cryopump depends on your process.

Set up the timer according to the process.

III. Pressure buildup check

Open the roughing valve (RV1), and rough pump cryopump to 40Pa. When it reaches 40Pa or less, turn OFF the heater (optional).

Then, close the roughing valve (RV1) and check the buildup of pressure in the cryopump. If the pressure buildup value stayed less than 6.5Pa

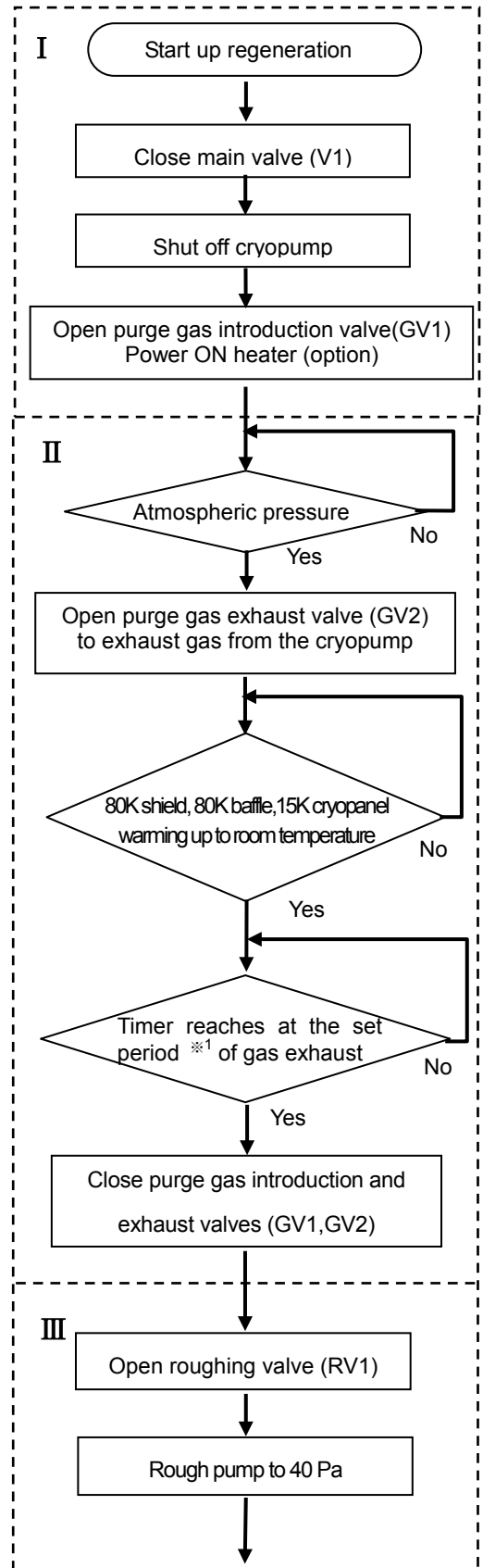

for five minutes, the roughing process has been completed. If it increased 6.5Pa or more in five minutes, repeat the rough pumping procedures to 40Pa and the pressure buildup check.

IV. Cool down

Open the roughing valve (RV1) after the pressure buildup check has completed.

Then rough pump the cryopump to 40Pa. Close the roughing valve (RV1) and start the cryopump. When the cryopump is cooled down to the prescribed temperature, the regeneration process is completed.

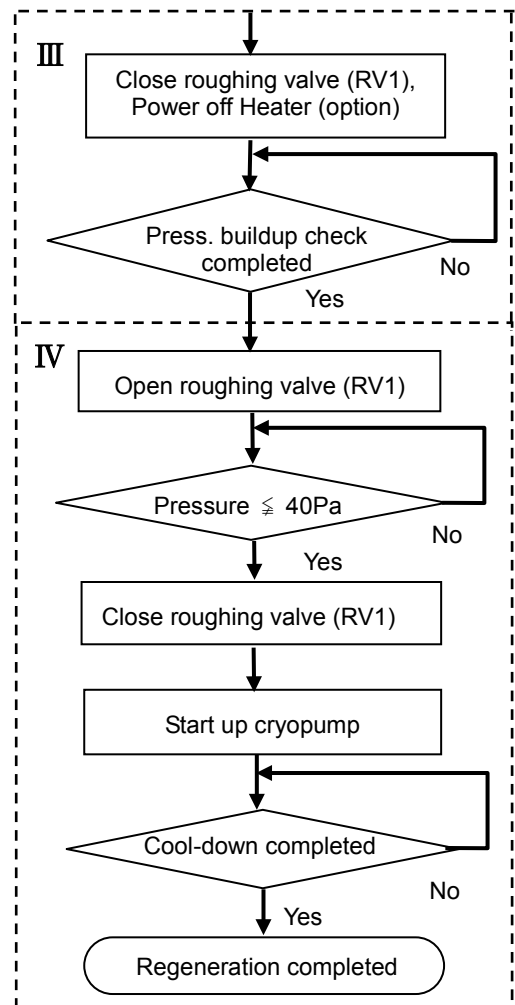

CAUTION

- When the main valve is not a reverse pressure compatible valve, start regeneration of the cryopump after returning the vacuum chamber to atmospheric pressure so that the main valve may not open during regeneration.
- A pump case might dew during warming up depending on the installation environment. In order to prevent a short circuit, please do not place an electric device under the cryopump.

† For Your Information †

- The warm-up time required for the 15K cryopanel to reach room temperature depends on the kind and quantity of the gas captured in the cryopump, or the warm-up method.
- If a large amount of the gas is amassed by the cryopump, the inner pressure of the cryopump may become higher than atmospheric pressure during warm-up process in the regeneration because most captured gas evaporates for a short time.

In this case, the pressure relief valve will open according to the following condition to release the gas. The pressure at which the pressure relief valve begins to open is 10 kPaG, and full open is 20 kPaG.

This page intentionally left blank.

7. DISCONNECTION and STORAGE

7.1	Disconnecting Flexible Hose	7-1
7.2	Storage	7-2

7.1 Disconnecting Flexible Hose



CAUTION

When disconnecting flexible hoses, be sure to use two single open end spanners with width across flat 26mm and 30mm.

1. Shut down the compressor unit.
2. After the cryopump has been warmed up to room temperature, disconnect the flexible hoses.



CAUTION

- If removing the flexible hoses before the refrigerator reaches room temperature, helium gas shut up into the refrigerator increases pressure with the rise of temperature, and may blow off from a pressure relief valve finally. It might cause a helium leakage also.
- However, only when carrying out helium circuit decontamination procedures for the refrigerator unit, disconnect the flexible hoses from helium gas supply and return connectors at the compressor unit side right after shutdown. Refer to Section 8.5 for more details.

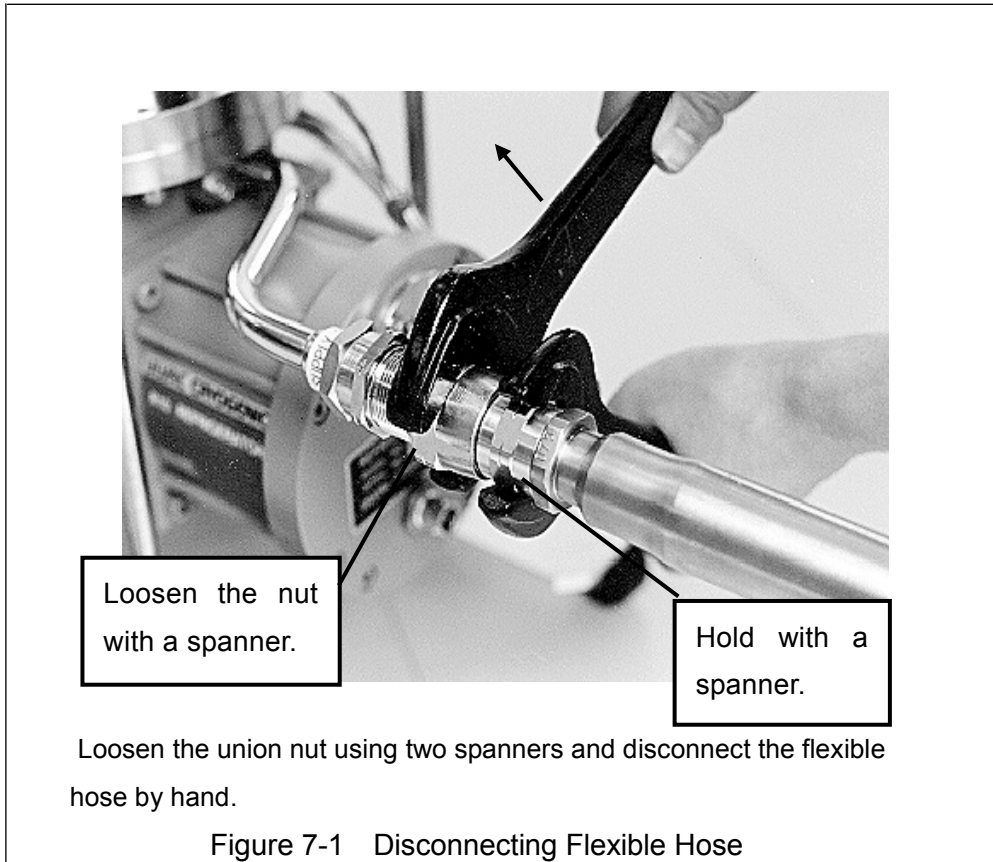

7.2 Storage



CAUTION

Do not expose the cryopump to atmosphere for a long time. It may adsorb moisture in the atmosphere and result in performance degradation.

- ◆ If the cryopump is stored in the state attached to your vacuum system, the cryopump should be kept in a vacuum (of 100Pa or less) or under the atmospheric pressure replaced with dry nitrogen.
- ◆ If the cryopump is removed from your vacuum system,
 1. After the cryopump has reached room temperature completely, disconnect the flexible hoses.

2. Before removing the cryopump from the vacuum chamber, make sure that the cryopump has reached room temperature after regeneration.
3. Put the protective cover on the mounting flange of the cryopump. Put the protective cap on the helium gas connector of the refrigerator.
4. Cover the entire body of the cryopump with vinyl sheet like the state when being delivered.
5. Fix the traveling base to the floor not to move around.
6. Cryopumps should be kept away from direct sun light, high temperature, humidity, dust, vibration, radiation, wind and rain.

◆ Shipment of the cryopump

Put all covers and caps as it was delivered and avoid excessive shock.

◆ Connect the refrigerator cable and operate the cryopump about 10 minutes biannually.

This work is effective in maintaining the grease lubrication of the bearings used in the refrigerator.

When the cryopump has been placed without operating for one year or more, perform cryopump decontamination before resumption of operation.

This page intentionally left blank.

8. MAINTENANCE

8.1	Scheduled and Unscheduled Maintenance	8-1
8.2	Consumables.....	8-3
8.3	Cleaning the Cryopump.....	8-4
8.4	Charging Helium Gas	8-5
8.5	Helium Circuit Decontamination	8-8

8.1 Scheduled and Unscheduled Maintenance

◇ Scheduled Maintenance:

- Check electrical insulation of the heater for regeneration
- Replace refrigerator parts
- Replace compressor adsorber

◇ Unscheduled Maintenance:

- Cleaning the cryopump
- Adding helium gas
- Decontaminating helium gas line
- Calibration of cryometer

Following items and helium gas are necessary for charging helium gas or helium line decontamination.

	Item	Volume	Item code
1	Helium charging adapter kit (Regulator, Charging hose 2.4M, Charging adapter)	1	A700B5101000
2	<Items independently available> Regulator (for helium gas) Charging hose 2.4M Charging adapter	1 1 1	A700A5101700 A700A5101800 A700B5101100
3	Helium gas (with purity of 99.999% or above)	—	—

Table 8-1 Maintenance Parts and Intervals

S: Scheduled maintenance **U:** Unscheduled maintenance or part replacement at fault

Item	Parts	Interval	Remarks
Cryopump			
U 80K baffle			When reassembling, be sure to use new indium gasket.
U 15K cryopanel replacement	15K cryopanel	At fault	
U Cryopump cleaning			
S Insulation properties of heater for regeneration (*1)	Heater	Every month	Replace when 10MΩ or less
S Pressure relief valve	Pressure relief valve	Once or twice per month	Check the safety of pumped gases.
U Calibration of cryometer	MBS-C Cryometer	At fault	Use the (paid) calibration service.
Refrigerator unit		RM120ET	
S Seal kit replacement	Seal kit	16,000h	The maintenance interval may vary depending on the frequency of use.
S Driver assembly Replacement	Driver bearing Valve bearing Set screw		
S Motor bearing replacement	Motor bearing		
S Cylinder bolt replacement	Cylinder bolt		
S Locking pin replacement	Locking pin	16,000h	
S Compression spring	Compression spring		
S Displacer replacement	1st /2nd stage displacer	16,000h	
S Valve body replacement	Intake/Exhaust valve body	16,000h	
U Other parts replacement	Other parts	At fault	
Compressor unit			
S Adsorber replacement	Adsorber	Refer to the compressor unit instruction manual.	

(*1): Only applicable to a cryopump system with heater.

8.2 Consumables

Following O-rings and gaskets are consumables for the cryopump.

Replace them with new ones as necessary.

Table 8-2 CRYO-U®20BLM Consumables ():type

	UVG-500	ISO500
Mounting flange	O-ring (V530)	O-ring (ISO530)
Accessory flange (C-type)	O-ring (AS568-020)	
Refrigerator flange	O-ring (G115)	
Pressure relief valve	O-ring (N5)	
KF25 port	O-ring with center ring for KF25	
KF40 port	O-ring with center ring for KF40	

- Notes:
- 1) Recommended material of O-ring: Viton
 - 2) Type N O-rings comply with the standard enacted by ULVAC Inc.
Other types of O-ring comply with JIS, ANSI or ISO standard.

8.3 Cleaning the Cryopump

   	WARNING
<p>When it seems that the cryopump has been used to pump toxic or dangerous materials, you must contact the safety supervisor for appropriate measures.</p>	

Deterioration of cryopump performance is mainly caused by contamination on the 80K shield and the 80K baffle. It is recommended to check the temperatures of these parts once a week with the main valve closed in order to observe the degree of contamination. When removing the cryopump from the vacuum chamber for purposes such as coldhead maintenance, inspect the 80K shield and the 80K baffle at the same time.

◆Cleaning the Inner kit

The 80K baffle is likely to be contaminated the most among the inner kit. Perform the 80K baffle cleaning as follows:

1. Remove the cryopump from the vacuum chamber and put the cryopump on the floor with the mounting flange up. At this time, be sure to support the cryopump not to fall down.
2. Wipe the 80K baffle with clean cloth dipped in alcohol.

When the 15K cryopanel is seriously corroded or contaminated, replace with new one.

15K cryopanel is soft and easily deformed. Handle them with care.

	CAUTION
<p>Do not wipe the blackened surface of the 80K shield with alcohol. The blackened surface may be peeled off with a solvent.</p>	

◆Maintenance of the pressure relief valve

	WARNING
<p>If the pressure relief valve is left capped for a long time, it may not be activated at required pressure.</p>	

We recommend maintenance procedures of the pressure relief valve as follows.



This maintenance is required once or twice a month. Check the safety of the gases captured in the cryopump before beginning the maintenance, since the inner kit in the cryopump is exposed to atmosphere when cleaning the pressure relief valve.

1. Remove the cap from the pressure relief valve.
2. Clean the pressure relief valve and the cap using the cloth moistened with alcohol.
Reinstall the valve and the cap after they dry.
3. O-rings will deteriorate by aging. It is recommended to replace them periodically.

◆ Maintenance of heater for regeneration

(Applicable only to a cryopump system with heater)

Periodical maintenance is required as shown in Table 8-1.

		WARNING
<p>Heaters for regeneration, either band heaters (RBH type, silicone rubber), sheathed or cartridge type, may deteriorate in nonconductivity with ageing. Be sure to install a ground-fault circuit interrupter, and conduct periodic inspections of the nonconductivity to prevent a short circuit.</p>		

8.4 Charging Helium Gas

The tools for charging helium gas (regulators, charging hoses) that can be used at 2.0MPaG or above are required

	CAUTION
<p>If the helium pressure gauge of the compressor unit shows 0 MPaG, contamination caused by air or moisture may have occurred in the system. If it occurs, contact our Service Engineering Division or customer support center.</p>	

When helium gas pressure is lowered, it is necessary to replenish the gas. Investigate the cause of the pressure reduction before adding helium gas. If there is a leakage, take an adequate measure before charging. Improperly connected self-sealing coupling might be one of the causes of the leakage.

◇ Recommended regulator is the one designed for helium gas (left-hand thread) and has the

pressure gauge of 4-6MPaG on low pressure side.

- ◇The gas charge inlet of the compressor unit is 1/4B male flare.
- ◇Use helium gas with purity of 99.999% or more.

Charge helium gas as follows:

1. When mounting the regulator on a new helium bottle, perform the following procedures in order to remove air and fill helium gas in the gas line between the regulator and the bottle valve first.
 - a. Turn the regulator handle clockwise to open the regulator a little.
 - b. Slowly open the bottle valve, and purge the regulator and gas line for several seconds.
 - c. Turn the regulator handle counter-clockwise to close the regulator.

**CAUTION**

Do not open the bottle valve immediately after attaching a regulator, as it diffuses the air between the regulator and bottle valve into the helium bottle and contaminates helium gas. Be sure to perform the above step 1.

**WARNING**

Never bring your face in front of the pressure gauge when opening the bottle valve or turning the regulator handle.

2. Remove the front panel of the compressor unit.
3. Connect the helium charging hose as follows:
 - a. Connect the charging hose to the regulator.
 - b. Loosely connect the charging hose to the charge inlet on the compressor unit so that helium gas can be slightly blown out here.
 - c. Open the regulator until the outlet pressure reaches 0.1 to 0.2 MPaG. Allow helium gas to flow out from the charging hose for about half a minute. Meanwhile, open the charge valve slightly in order to drive out the air that exists between the charge valve and the charge inlet.
 - d. Tighten the flair nut at the end of charging hose and close the charge valve. Helium gas has now been charged in the line between the regulator and the charge valve.

4. Adjust the outlet pressure of the regulator at 1.8 MPaG. Pressure relief valve has to be mounted as well as the regulator. The set pressure of the pressure relief valve is 2.4MPaG.
5. Open the charge valve slowly and follow the steps below according to the state of the compressor.
 - a. If the compressor unit is running under normal operating conditions, charge pure helium gas until it reaches the operation pressure described in the compressor instruction manual.
 - b. If the compressor unit is suspended, replenish it with the pure helium gas until it reaches to the static pressure which is indicated on the front panel.



CAUTION

If helium gas has been charged more than the appropriate pressure and above 1.9MPaG, the pressure relief valve on the refrigerator may work. Charge helium gas slowly to prevent the pressure relief valve from being activated. The pressure relief valve in the compressor unit is set at 2.5MPaG.

6. Close the charge valve after charging helium gas.
7. Close the regulator and remove the charging hose from the charge inlet.

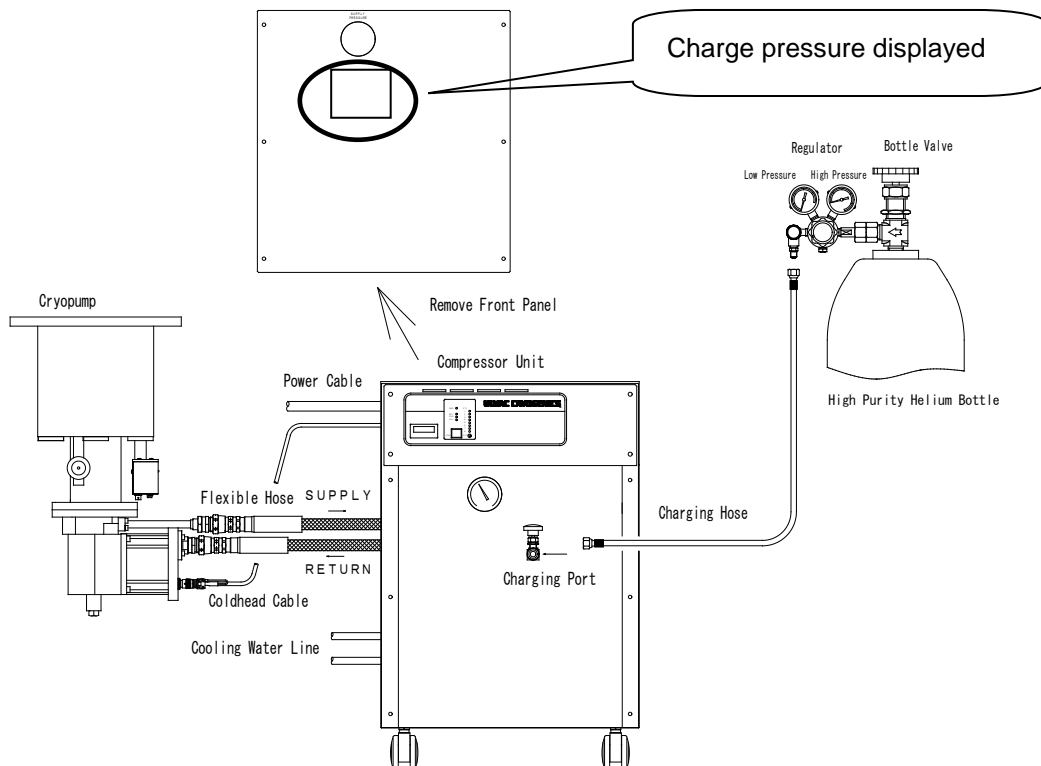

Figure 8-1 Charging Helium Gas

8.5 Helium Circuit Decontamination

The tools required for charging helium gas (regulators, charging hoses, adapters) should be able to be used at 2.0MPaG or above.

When helium gas in the cryopump system is contaminated, it is necessary to replace the gas inside with pure helium gas. (Refer to Appendix A- Troubleshooting.)

Contamination of helium gas in the cryopump system is caused by inadequacy of helium charge at the time of refrigerator unit maintenance. If impurities in helium gas are coagulated and deposited into the refrigerator, the performance of refrigerator could be deteriorated and abnormal vibration of the motor (called Step-out*) may occur. Follow the steps below to perform helium decontamination.

*Step-out: means that a refrigerator motor has an irregular or intermittent movement.

1. Turn on the cryopump system (refrigerator unit) and keep the running for three to four hours.

NOTE:

Since all impurities in the helium gas are condensed and solidified within the refrigerator during operation of the cryopump (refrigerator), a certain amount of cooldown time is required before beginning the decontamination procedures. If an irregular and abnormal sound or a big vibration arises during the operation, proceed to the next step (2).

2. Shut down the cryopump (refrigerator unit) as follows:
 - a. Close the main valve of your vacuum system.
 - b. Turn off the compressor unit.

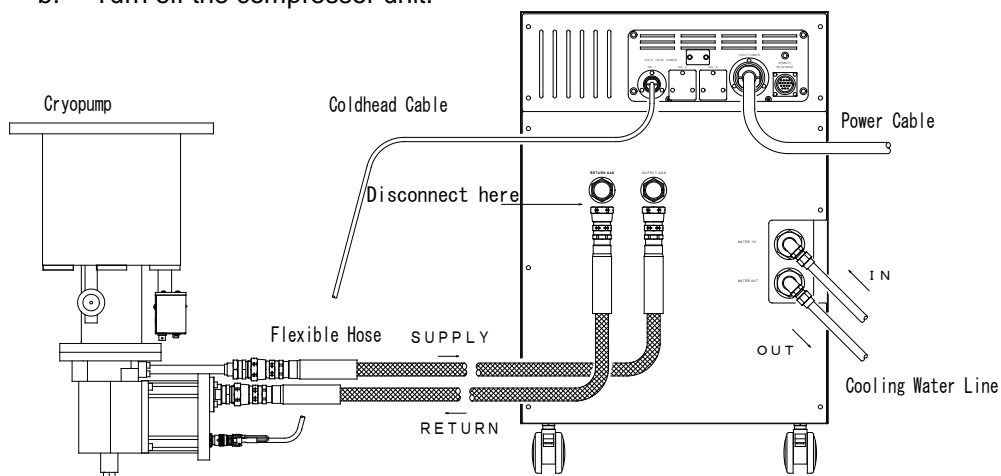

Figure 8-2 Disconnecting Flexible Hoses

3. Right after shutdown of the system, disconnect the helium SUPPLY and RETURN flexible hoses at rear of the compressor unit. (See Figure 8-2.)

NOTE:

It is important to remove flexible hoses right after shutdown in order to prevent the impurities condensed and solidified inside the refrigerator unit from being evaporated and diffused, resulting in deterioration of helium purity inside the compressor unit.

4. Connect SUPPLY and RETURN flexible hoses to the charging adaptor. (See Figure 8-3)
5. Reduce the pressure in the refrigerator unit and the flexible hoses to a level of 0.3MPaG by opening the valve(V1) of the charging adaptor.

NOTE:

As refrigeration lowers the temperature of helium gas in the refrigerator unit, the density of the gas increases. After the refrigerator is shut down, helium gas inside the refrigerator warms up and returns to room temperature, and the inner pressure rises as well. The unit has a pressure relief valve which opens at 1.9MPaG or above. Once the pressure relief valve opens, it is likely to cause leakage depending on the ambient conditions such as dust. Take measures to reduce the inner pressure immediately after refrigerator shutdown to prevent the pressure relief valve from being activated.

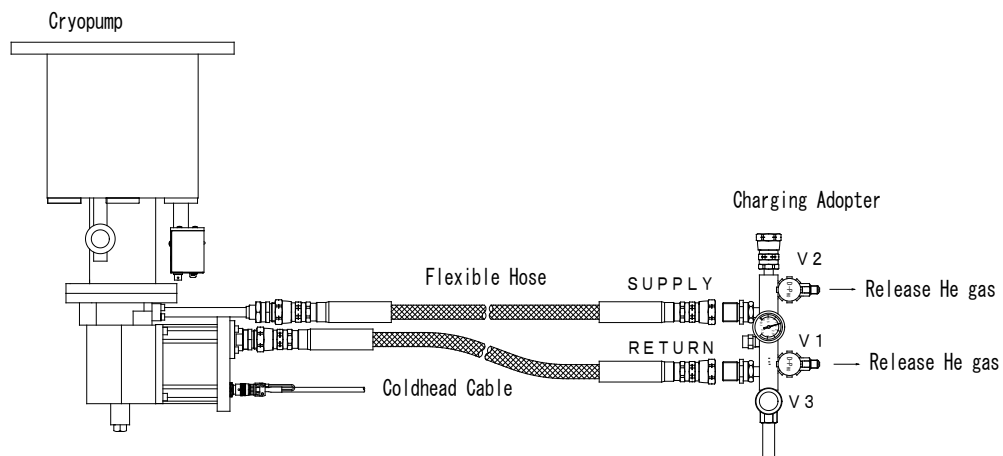

Figure 8-3 Connecting Charging Adaptor

- Warm up the cryopump (refrigerator unit). Allow the 15K cryopanel (the second stage) to reach to room temperature and further wait until the inside of the refrigerator unit reaches to room temperature. Normally it takes several hours and it is recommended to wait for eight hours or more.



CAUTION

If a cryopump is exposed to the atmosphere while warming up, charcoal on the 15K cryopanel will adsorb large amount of moisture, resulting in extended regeneration time.

† For Your Information †

Performing the assisted warm-up procedures described in Section 6.3 of this manual can shorten the time required for warm-up.

Before proceeding to the next steps, make sure that the 15K cryopanel has reached room temperature.

- Connect the helium bottle and the regulator. Replace the air remained between the helium bottle valve and the regulator with helium gas as instructed in Section 8.4 – Charging Helium Gas.

Use helium gas with purity of 99.999% or above.

- Perform decontamination procedures as follows:

Rough pumping system as indicated in Figure 8-4 and a roughing pump are required. A roughing pump with pumping speed of 20L/min or above and the ultimate pressure of 10Pa is recommended.

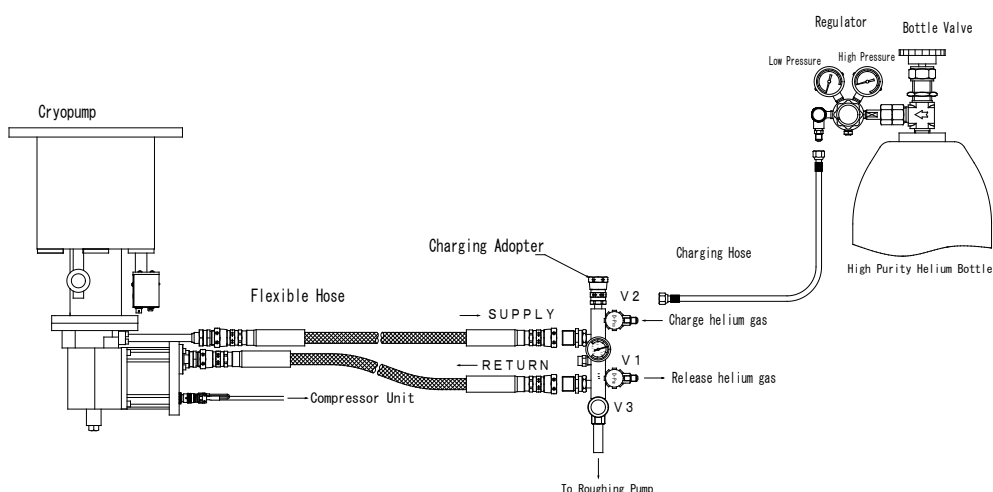

Figure 8-4 Cryopump Decontamination Procedure (1)

- a. Loosely connect the charging hose to the charge valve (V2) on the charging adapter.
- b. Open the regulator until the outlet pressure reaches 0.1 to 0.2 MPaG. Allow helium gas to flow out from the charging hose for about half a minute. Meanwhile, open the charge valve (V2) slightly in order to drive out the air trapped in the charge valve.
- c. Tighten the flair nut at the end of charging hose and close the valve (V2).
- d. Turn on the roughing pump and open the valve (V3) slowly. Rough pump helium gas inside the refrigerator unit while maintaining pressure below the maximum allowable level of the roughing pump. When the pressure becomes below the atmospheric pressure, fully open the V3 valve. Maximum allowable pressure of ULVAC's small oil-sealed rotary pump and drypump is 0.01MPaG. Check the pressure with an appropriate pressure gauge.

**CAUTION**

Make sure to open the valve slowly when exhausting the gas beyond the atmospheric pressure in order to maintain the pressure of the pump head below an allowable value. If you open it quickly and widely, the roughing pump may break down.

- e. After rough pumping for more than 30 minutes, close the valve (V3). Shut off the roughing pump to bring it back to the atmospheric pressure.
- f. Adjust the outlet pressure of the regulator at 1.8MPaG. Then open the valve (V2). Charge helium gas until the pressure gauge on the charging adapter reaches 1.5MPaG and then close the valve (V2).
- g. Startup the compressor unit to operate the refrigerator unit. By operating the refrigerator unit, helium gas is circulated through the refrigerator and the flexible hoses. See Figure 8-5.

**CAUTION**

Do not operate the refrigerator unit when it is at a negative pressure. It may invite vacuum discharge in the refrigerator motor, resulting in equipment failure. Helium gas charge has to be completed before starting the refrigerator.

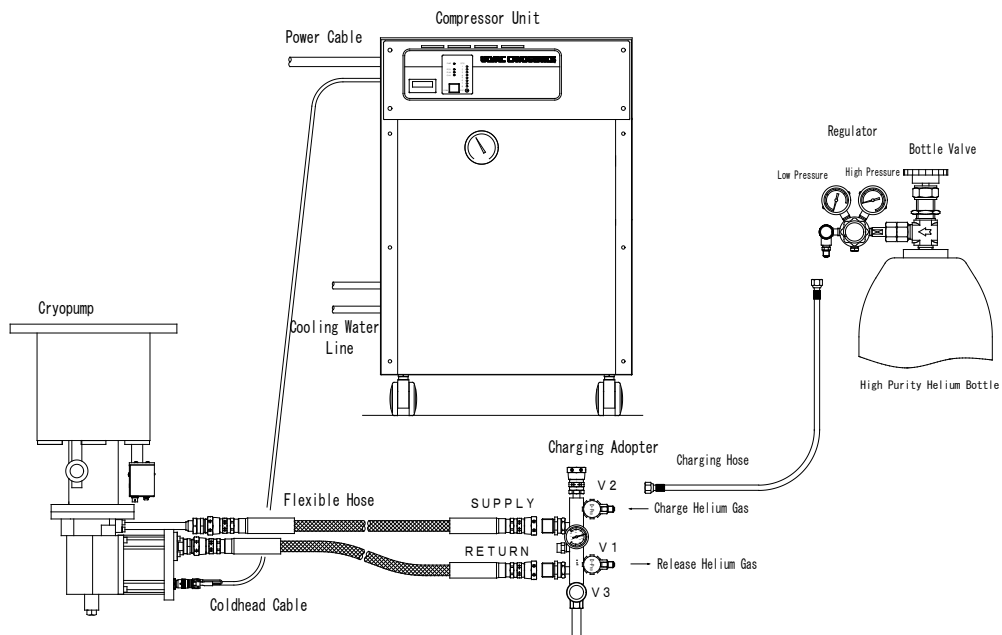

Figure 8-5 Cryopump Decontamination Procedure (2)

- h. Open the valve (V1) to discharge helium gas while operating the refrigerator unit, and then close the valve (V1) when the pressure is reduced to 0.4MPaG
- i. While running the refrigerator, open the V2 of the charging adaptor, charge helium until 1.5MPaG and close the valve. Open the V1 and release gases until 0.4MPaG. Repeat these steps slowly for 25 times. This improves helium quality between refrigerator unit and flexible hoses.
9. Shutdown the refrigerator unit. Charge helium gas to the refrigerator unit and the flexible hose until they reach the appropriate value static charge pressure of the compressor unit.
10. Remove both SUPPLY and RETURN flexible hoses from the charging adaptor.
11. Connect the SUPPLY and RETURN flexible hoses to the compressor unit again (See Figure 8-6)..

Make sure that the flat rubber gasket of the self-sealing coupling is not removed nor twisted. Then connect the flexible hoses to the compressor unit.

**CAUTION**

The pressure relief valve on the refrigerator unit may work if the charge inlet of SUPPLY /RETURN at the compressor unit and SUPPLY /RETURN flexible hoses are connected reversely, and this requires maintenance servicing. Make sure that they are connected correctly.

12. Confirm that the pressure gauge on the front panel of compressor unit indicates the appropriate pressure (indicated on the front panel). If not, charge helium gas through the charging valve of the compressor unit again, or adjust the pressure by discharging the helium gas.
13. Restart the cryopump (refrigerator unit).

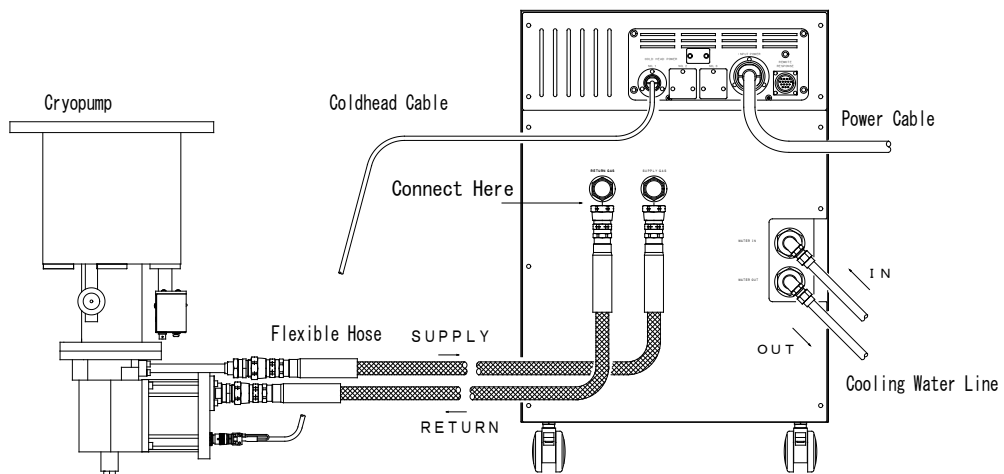

Figure 8-6 Connecting Flexible Hoses

This page intentionally left blank.

Appendix A

Troubleshooting

Most of breakdowns of CRYO-U® cryopump come to light as a rise in temperature and/or pressure through the following two routes.

(1) Refrigerator broken down → Cryogenic performance lowers → Temperature rises → Pressure rises



(In case of the breakdown of the refrigerator, the rise in temperature or pressure will rapidly occur in minutes or hours)

(2) 80K shield and 15K cryopanel contaminated → Thermal load increases → Temperature rises → Pressure rises

(In this case, the rise in temperature or pressure will usually slowly occur in months or years according to the use environment.)

Regarding various potential failures, the item I to VII in Table A-1 explains its cause and measure respectively. When the trouble cannot be solved, please contact our Service Engineering Division or the nearest customer support center.

Table A-1 Cryopump Fault Diagnosis

Problem	Possible cause	Corrective action
<p>I . It takes too long to rough pump the cryopump. Or, the pressure buildup speed from 40Pa is greater than 1.3Pa/min.</p>	<p>1) A leakage through a pressure relief valve.</p>	<p>Remove a cap of the pressure relief valve rotating in anticlockwise direction. Clean the O-ring and O-ring sheet.</p> <div style="border: 1px solid black; padding: 5px;">  <p>WARNING</p> <p>Confirm the safety of the gas which may blow off from the pump before removing the pressure relief valve. Do not block the pressure relief valve.</p> </div>
	<p>2) A large amount of gas with low vapor pressure, such as water is adsorbed on the charcoal of 15K cryopanel (2).</p>	<p>Introduce dry nitrogen or argon into the cryopump and repeat rough pumping.</p>
	<p>3) Inner kit is contaminated with oil or deposition material.</p>	<p>Clean the inner kit or replace it with a new one.</p>
	<p>4) There is a leakage in the cryopump or the vacuum system.</p>	<p>Find and stop the leak.</p>
<p>II . Neither the compressor unit nor the cryopump start.</p>	<p>Consult the instruction manual of compressor unit for details.</p>	
<p>III . A compressor unit starts, but a cryopump doesn't start. Or the cryopump is stopped, but the compressor unit is running continuously.</p>	<p>1) A refrigerator power cable is not connected to the refrigerator unit. 2) In case of multi-operation of the refrigerator unit, ON/OFF state of the refrigerator is decided with the control signal of the system that a user prepares. Therefore, check your control method to judge whether the halt condition of the refrigerator is normal or not.</p>	<p>Turn off the compressor unit and connect the refrigerator power cable to the refrigerator unit.</p> <div style="border: 1px solid black; padding: 5px;">  <p>CAUTION</p> <p>Do not connect the refrigerator power cable to the refrigerator unit without turning off the compressor unit. The refrigerator motor may be damaged if this caution is not followed.</p> </div>

Problem	Possible cause	Corrective action
<p>III. (Continued)</p> <p>A compressor unit starts, but a cryopump doesn't start. Or the cryopump is stopped, but the compressor unit is running continuously.</p>	<p>3) The drive motor of a refrigerator unit has mechanical damage.</p> <p>① Motor shaft failure or bearing defects.</p> <p>② Drive motor circuit failure.</p>	<p>Check whether there is sound which shows a motion of a motor by turning on and off the switch of the refrigerator.</p> <p>When no sound or irregular beat comes from the motor, contact our Service Engineering Division or the nearest CS center.</p> <p>Measure resistance and insulation resistance between the drive motor connector pins (Impressed voltage: DC 500V) and inform us the measured values with S/N of the refrigerator unit.</p>
<p>IV.</p> <p>The cryopump fails to cool down to 20K or lower at the time of startup.</p>	<p>1) Helium Supply/Return line incorrectly connected.</p> <p>Self-sealing coupling is not fully tightened.</p>	<p>Properly connect the flexible hoses referring to Sec. 4.7.</p> <p>Check that all self-sealing couplings are fully connected referring to Figure 4-5.</p>
	<p>2) Pressure in the cryopump is too high.</p>	<p>Make sure that there is no leakage.</p> <p>The cryopump may fail to cool down due to thermal load of the gas caused by a leakage.</p>
	<p>3) Heat load to the cryopump is too high.</p>	<p>If the temperature of the cryopump rises when opening the main valve, heat input amount from the user's device is over the acceptable value. In this case, take measures to reduce the heat load.</p> <p>If the cryopump still fails to cool down to 20K or lower even when the main valve is closed, the refrigerator unit may be out of order. Contact our Service Engineering Division or the nearest CS center.</p>

Problem	Possible cause	Corrective action
(Continued)	4) Failure of the refrigerator unit or the compressor unit.	Contact our Service Engineering Division or the nearest CS center.
<p>V.</p> <p>Pumping performance of the cryopump is lowered.</p> <p><u>Examples</u></p> <ul style="list-style-type: none"> • Temperature is higher than the normal value. • Pumping speed is falling. • Vacuum level has worsened. • Helium gas filling pressure is lower than the specified value. 	1) The ultimate pressure of the vacuum chamber after roughing is still high.	Rough pump to the maximum allowable crossover pressure or less (Recommended value: 40Pa). Refer to Sec. 5.6 for details.
	2) A large amount of gas has been captured.	Regenerate the cryopump as described in Sec.6.
	3) High partial pressure of helium remained in the cryopump.	Purge helium with dry nitrogen gas to reduce the partial pressure of helium.
	<p>4) Leakage</p> <p>① Air-to-vacuum leakage at attaching parts or ports on the cryopump.</p> <p>② Helium leakage caused by the slack of helium gas joint.</p>	<p>Detect the leakage by the evacuation method using a helium leak detector or mass analyzer, and stop the leakage.</p> <p>Detect the leak point by Sniffer method using a helium leak detect or or by the bubbling method with soap, and stop the leakage.</p> <p>If no leak is found, contact our Service Engineering Division or the nearest CS center.</p>
<p>5) Internal equipments of the cryopump becomes loose in the following parts:</p> <p>① Thermometer mounting bolts.</p> <p>② Mounting bolts of 80K shield, 80K baffle, and 15K cryopanel.</p>	<p>If necessary, disassemble the cryopump and remount the temperature sensing part firmly to the second stage of the refrigerator unit. Replacement of the indium sheet is required.</p> <p>If necessary, disassemble the cryopump and retighten all screws. Replacement of the indium sheet is required.</p>	

Problem	Possible cause	Corrective action
V. (Continued) Pumping performance of the cryopump is lowered.	6) Performance of the refrigerator is deteriorated. ① Helium gas is heavily contaminated. ② Helium filling pressure is deficient.	Perform decontamination procedures described in Sec.8.5. Use helium gas with purity of 99.999% or more. Add helium gas with purity of 99.999% or more to the specified value. If no cause is found, contact our Service Engineering Division or the nearest CS center.
	7) Performance of 15K cryopanel is deteriorated. ① Excessive water vapor adsorption . ② Since the roughing valve was accidentally opened in the cold condition of the cryopump, the panel has been contaminated with impurities gas. ③ Since rough pumping was performed at 13Pa or less for a long time using the oil-sealed rotary pump, the panel has been contaminated with oil.	Introduce dry nitrogen or argon and repeat rough pumping. Or, heat the cryopump with a band heater or an inner heater (available as option). Replace 15K cryopanel. When an oil-sealed rotary pump is used for rough pumping, the panel may be contaminated with oil. Replace 15K cryopanel. Be sure not to perform rough pumping at 40Pa or less for a long time.

Problem	Possible cause	Corrective action
<p>VI. Regeneration is required at short intervals.</p>	<p>1) Incomplete regeneration Regeneration temperature is so low that the water in the absorbent cannot be dried out.</p>	<p>① Perform regeneration as described in Sec.6. Warm the first stage and the second stage up to room temperature. ② Repeat introduction of dry nitrogen gas and rough pumping. This is the most effective way. ③ After rough pumping, confirm that the pressure buildup speed from 40Pa is 1.3Pa/min or less.</p>
	<p>2) Leakage in vacuum system.</p>	<p>Detect and stop the leakage.</p>
<p>VII. Refrigerator drive motor is making irregular or intermittent motion.</p>	<p>1) Helium gas is heavily contaminated.</p>	<p>Perform cryopump decontamination procedures as described in Sec.8.5. Use helium gas with purity of 99.999% or more.</p>
	<p>2) Input voltage to the motor is low.</p>	<p>Check the input voltage to the compressor and the refrigerator. Optimum voltage of the refrigerator unit is 144V for two-phase motor and 200V for three-phase motor. Because it should be a check under the hot line condition, an appropriate maintenance person in charge needs to check.</p>

This page intentionally left blank.

Appendix B

FLEXIBLE HOSE

1. Specifications of 20A Flexible Hose

- Gas : Helium Gas (Purity: 99.999% or above)
- Pressure : Max. 2.45MPaG
- Temperature : 0 to 70°C
- Material : SUS304
- Length : 5000mm (standard)
- Minimum Bending Radius : 250mm
- Recommended Torque for Connecting : 20N·m

***Fasten self-sealing couplings until they stop rotating.**

- Connection : 1/2B self-sealing coupling

2. Precaution for Handling



CAUTION

- When carrying a flexible hose, hold around the braid support to prevent damage. Bending it forcibly at an acute angle may result in damage.
- Avoid twisting the flexible hose especially when making continuous bend connections.
- Keep away from water and salt to prevent corrosion. Do not place heavy objects on the flexible hoses in order to prevent deformation or crushing.

This page intentionally left blank.

Appendix C

CONVERSION OF THERMOMETER READINGS

1. K(CA) Thermocouple Electromotive Force

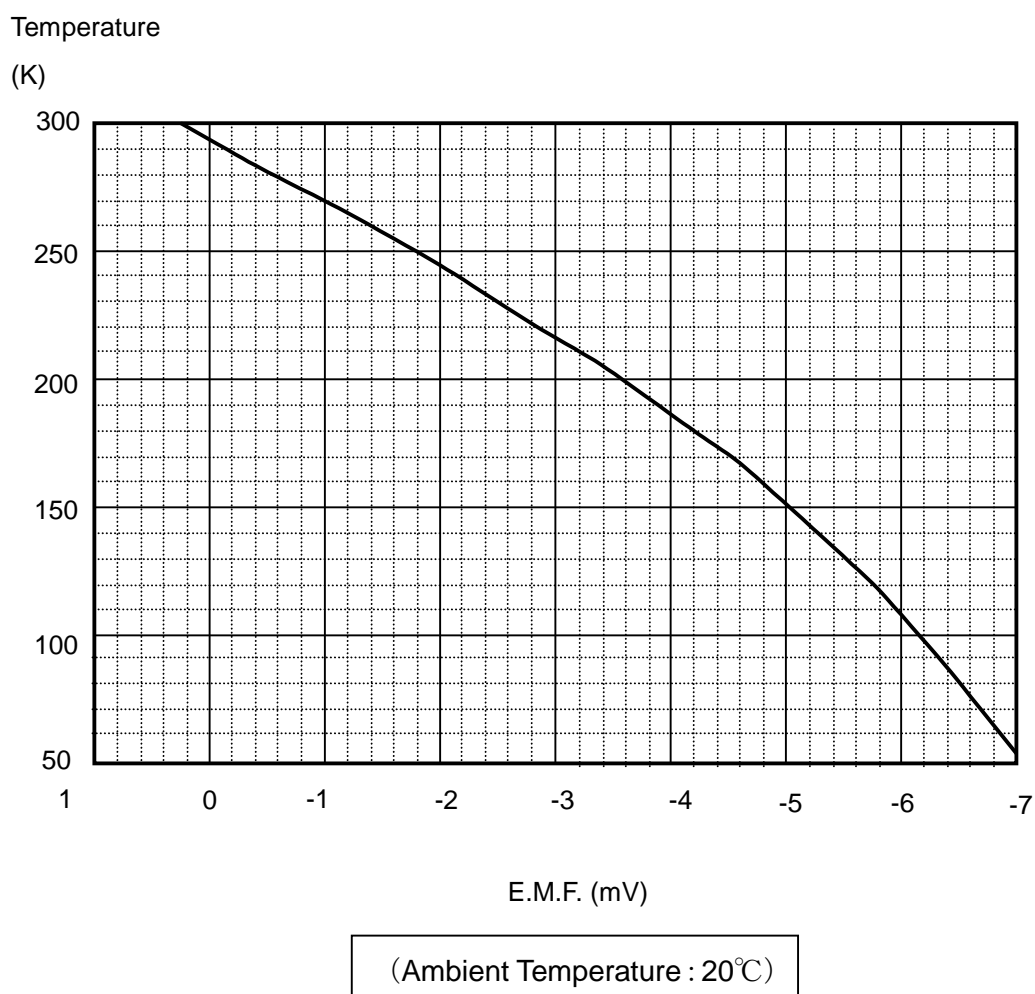

2. Hydrogen Vapor Pressure Gauge

Vapor Pressure
MPaG

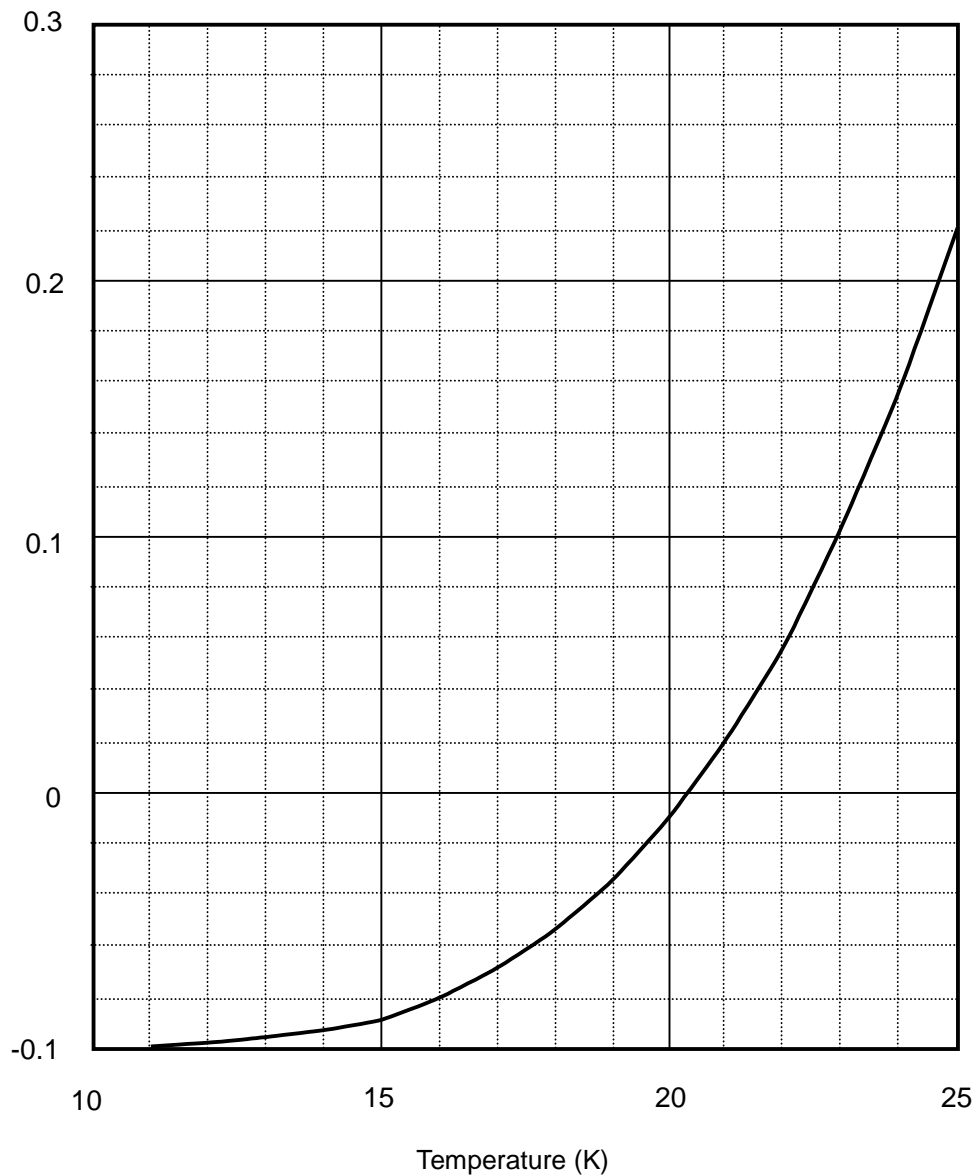
**NOTE:**

The indicated value of the hydrogen vapor pressure gauge changes depending on the atmospheric pressure of the altitude. A true temperature can be read by applying the vapor pressure calculated by the following formula to the above figure.

$$\text{Vapor pressure [MPaG]} = \text{Indicated pressure} - (0.1013 - \text{Atmospheric pressure at the altitude})$$

Appendix D

PRINCIPLE OF CRYOPUMP OPERATION

Evacuation operation of the cryopump is accomplished by causing the gas molecule hit on a surface (cryo surface) cooled to extremely low temperature to be condensed and absorbed on the cryo surface.

Our CRYO-U® series cryopump uses a helium refrigerator for cooling the cryo surface and clean high vacuum and extra-high vacuum can be obtained by simple operation.

The cryo surface is cooled to 12K to 20K according to the heat load.

When the cryo surface is cooled to 20K, the vapor pressure of nitrogen condensed on this surface is less than 10^{-8} Pa (refer to Fig.D-1). Therefore, gas (oxygen and argon, etc.) whose vapor pressure is lower than that of nitrogen is normally condensed on the cryo surface and evacuated.

Vapor pressure of neon, hydrogen and helium is 0.1Pa or more even at 12K, and the CRYO-U® series cryopump cannot condense these gasses on the cryo surface. Such gasses are absorbed and evacuated by the absorbent installed on the cryo surface.

Since the cryopump evacuates gas, as stated above, by condensing or absorbing the gas on the cryo surface, evacuated gas is accumulated on the cryo surface. In the case of condensation, when the quantity of the gas condensed on the cryo surface increases and the condensed layer reaches certain thickness, surface temperature of the condensed layer rises and the condensing speed of the gas molecules is lowered. In the case of absorption, when the quantity of the absorbed gas approaches to the saturated absorbed quantity decided according to the temperature of absorbent and the pressure of absorbed gas, absorbing speed of the gas molecules is lowered considerably. Mainly due to these 2 factors, evacuation performance (pumping speed and ultimate pressure) of the cryopump indicates remarkable reduction from certain point with an increase in the quantity of the evacuated gas. Therefore, it is necessary to set the temperature of the cryo surface to the room temperature periodically, vaporize the condensed/absorbed gas components and exhaust them to the outside. This operation is called “regeneration” by which the performance of the cryopump can be recovered through the “temperature rise (exhaust of gas) -> degassing -> cooling” process.

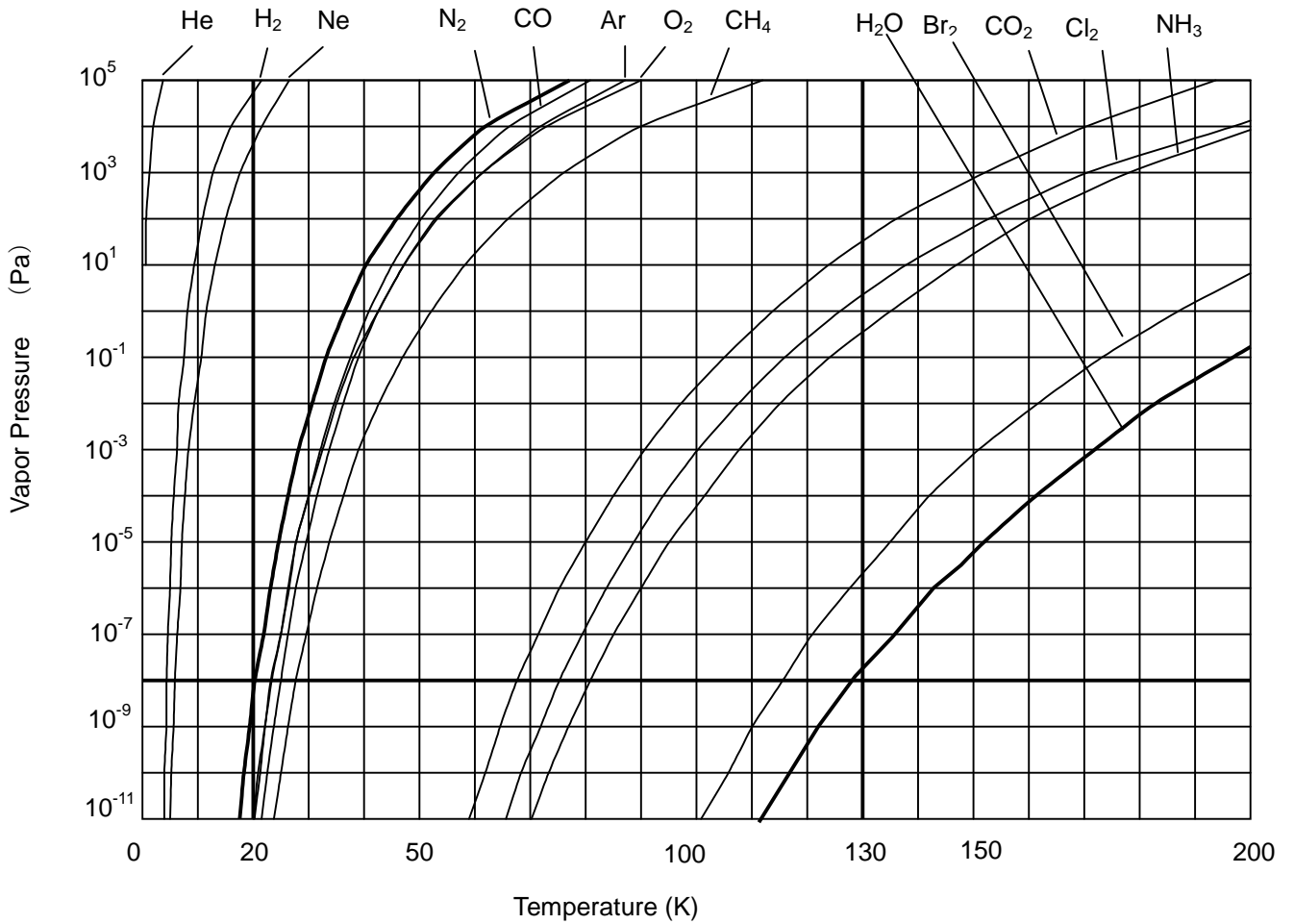

[R.E.Honing and H.O.Hook: RCA Review (Sept. 1960)]

Figure D-1 Vapor Pressure of Various Kinds of Gas

Appendix E

PRINCIPLE OF REFRIGERATOR OPERATION

Helium gas is used as heat-medium gas of a refrigeration cycle in refrigerator system, because it does not liquefy even 10K.

First, after the helium gas is compressed into high pressure and being continuously cooled by water-cooling or air cooling to room temperature within the compressor unit, it will be introduced into the refrigerator when the valve A opens. Then the helium gas is cooled by heat exchange between the regenerator and led to an expansion chamber with a rise of a displacer. Next, because the valve B opens at the same time the valve A closes, the high-pressure helium gas in the expansion chamber is exhaled toward the low pressure part of the compressor unit with the differential pressure. During this process, the pressure and temperature of the helium gas in the expansion chamber decreases (called Simon expansion). The cooled low-pressure helium gas is discharged completely from the expansion chamber by the descent of the displacer. As the helium gas passes through the regenerator again, it will be warmed up to room temperature and return to the compressor. At this moment, however, the regenerator is cooled down conversely. In this way, a refrigeration cycle returns to the first state. By repeating this refrigeration cycle, cryogenic temperature is obtained.

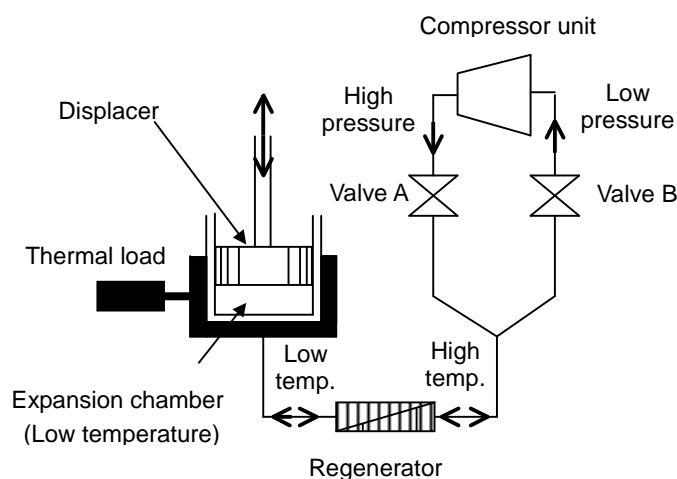

Figure E-1 Principle of Refrigeration

G-M Cycle

Gifford and McMahon developed the concept of G-M cycle in the late 1950's. In the driving method of G-M cycle, there are a way which drives mechanically and a way which drives using the differential-pressure of the operational gas. Since the GM cycle is efficient, it can make drive speed late. Moreover, the load concerning the seal currently used for an inside is also light. Therefore, it is a highly efficient and reliable refrigeration cycle. In this manual, the refrigeration cycle with the mechanical driving system adopted by ULVAC CRYOGENICS INC is explained.

Figure E-2 shows the principle of G-M cycle & P-V chart (P: pressure, V: volume in the expansion chamber).

- A The displacer is first positioned at the bottom of the cylinder.
 ↓
 The low-pressure valve is closed and the high-pressure valve is opened.
- a The compressed helium is introduced into the warm end and the cold end (the expansion chamber) of the cylinder.
 ↓
- B Pressure inside the cylinder increases.
 ↓
- b When moving a displacer up, the cold end (expansion room) is filled up with the helium gas of room temperature, being cooled by the regenerator.
 ↓
- C The volume of the cold end (the expansion chamber) is now maximum.
 ↓
 At this time the high-pressure valve is closed and low-pressure exhaust valve opened.
- c The compressed helium in the cold end (the expansion chamber) is expelled through the regenerator causing a temperature decrease by Simon expansion.
 ↓
- D The cold end obtains the lowest pressure.
 ↓
- d The displacer is moved to the initial lower position and the low-temperature helium is transferred to the compressor. The temperature of the gas returns to room temperature by heat exchange between the regenerator.
 ↓
- A One cycle of the helium gas circulation is completed.

The P-V diagram of idealized G-M cycle shows a quadrangle.

The ideal refrigeration ability “ Q_{ideal} ” is as follows when indicating the period of one cycle as “ t ” minutes:

$$Q_{\text{ideal}} = W / t$$

In the actual refrigerator, the structure with two stages is adopted in order to gain cryogenic temperature of 15K or less as shown in Figure E-3. In order to simplify structure, the regenerator is built into the inside of the displacer, and it is unifying. Moreover, since difference pressure is not applied to seals on the 1st stage and 2nd stage, the structure where the load to the seal is light has been adopted. Therefore, a long-lived, high reliability is acquired.

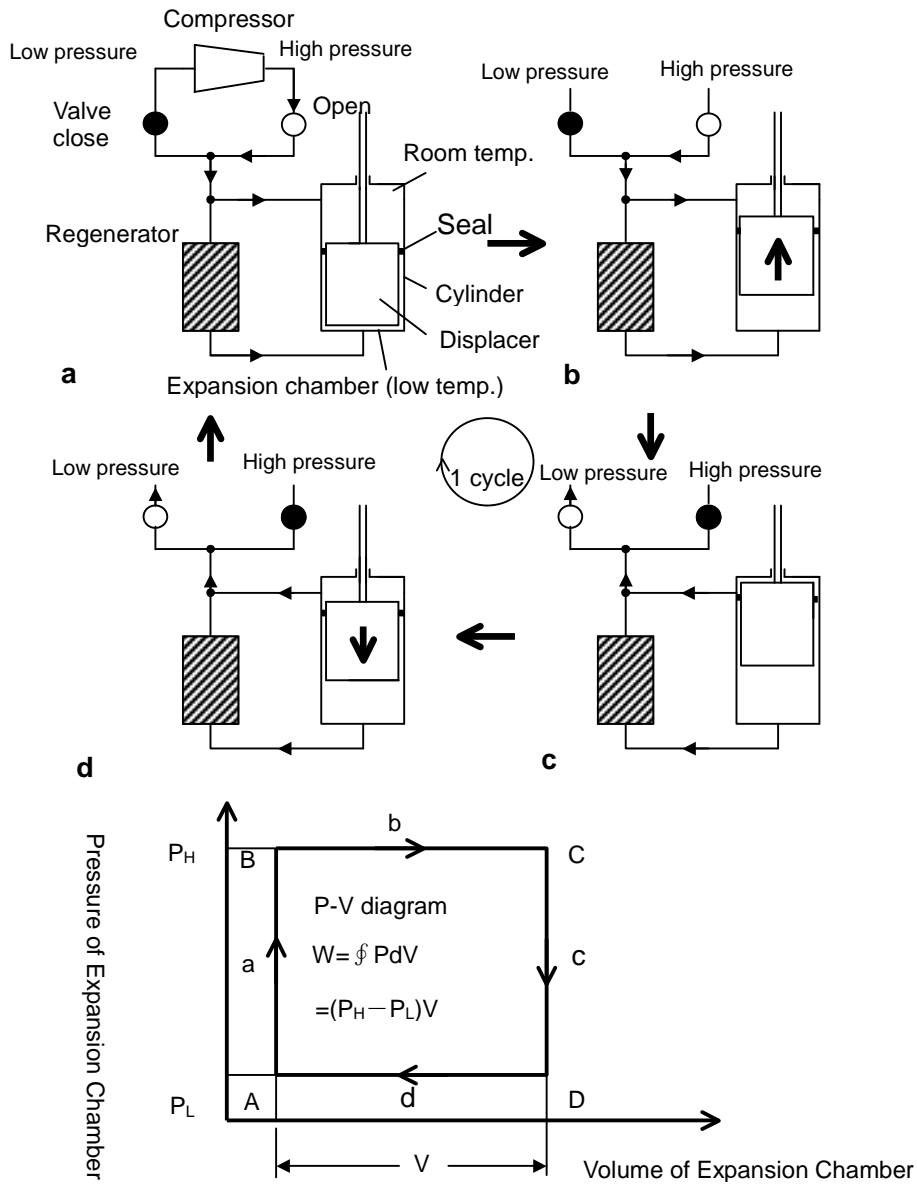

Figure E-2 Principle of G-M Cycle Operation

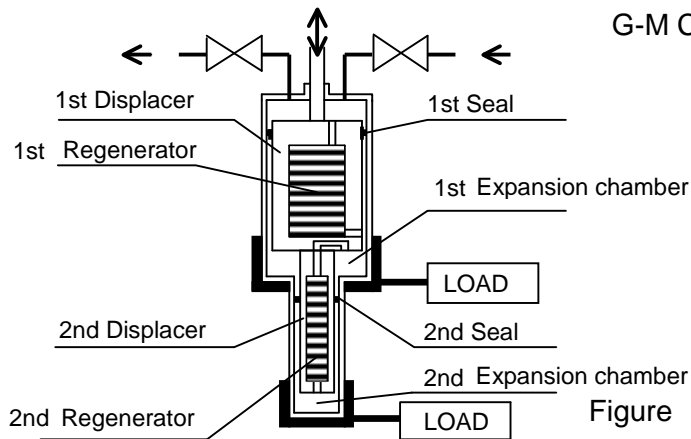

Figure E-3 Two-stage Refrigerator

Appendix F

DEW CONDENSATION

1. Dew Condensation on a Cryopump

A cryopump accumulates frozen gases on the inside arrays using refrigeration. Dew condensation may occur on the cryopump case under the conditions as follows. Cares must be taken to prevent short circuit in electrical parts around the cryopump.

When		Cause of Condensation	Corrective Action
In Operation	(1)	Dew condensation occurs as the surface of the cryopump case reaches dew point under current ambient temperature and humidity.	Use an air conditioner to keep optimal temperature and humidity. Refer to the Dew Point Table on the next page.
	(2)	Residual moisture inside is frozen due to insufficient regeneration.	Perform the regeneration work again, confirm that the cryopump passes the pressure buildup check, and start cooling down.
	(3)	Vacuum level inside the cryopump is insufficient during cooldown.	If the vacuum level does not improve, rough pump again with a dry pump that has no oil backflow. When the vacuum level is gradually improving, adiabatic vacuum is kept when the cooldown is completed and dew disappears.
In Regeneration	(4)	Frozen gases that have been accumulated fall from the inner kit.	Use band heaters for regeneration. Use heat insulating material when condensation is severe.
	(5)	Residual moisture is frozen during rough pumping	Go through the regeneration process again, confirm that the cryopump passes the pressure buildup check, and start refrigeration.

2. Dew-Point Temperature

The intersection of temperature and relative humidity indicates the dew point. Dew condensation occurs when the surface of the cryopump case is below the dew point.

		Relative Humidity (%)								
		20%	30%	40%	50%	60%	70%	80%	85%	90%
Temperature (°C)	10	-12.0	-6.0	-2.6	0.1	2.6	4.8	6.7	7.4	8.4
	11	-11.1	-5.9	-2.1	1.0	3.5	5.7	7.7	8.4	9.4
	12	-10.3	-5.0	-1.2	1.9	4.5	6.7	8.7	9.4	10.4
	13	-9.5	-4.2	-0.3	2.8	5.4	7.7	9.6	10.4	11.4
	14	-8.6	-3.3	0.6	3.7	6.4	8.6	10.6	11.3	12.4
	15	-7.8	-2.4	1.5	4.7	7.3	9.6	11.6	12.4	13.4
	16	-7.0	-1.6	2.4	5.6	8.2	10.5	12.6	13.3	14.4
	17	-6.1	-0.7	3.3	6.5	9.2	11.5	13.5	14.3	15.3
	18	-5.3	0.2	4.2	7.4	10.1	12.4	14.5	15.2	16.3
	19	-4.5	1.0	5.1	8.4	11.1	13.4	15.5	16.3	17.3
	20	-3.6	1.9	6.0	9.3	12.0	14.4	16.4	17.2	18.3
	21	-2.8	2.8	6.9	10.2	12.9	15.3	17.4	18.2	19.3
	22	-2.0	3.6	7.8	11.1	13.9	16.3	18.4	19.2	20.3
	23	-1.0	4.5	8.7	12.0	14.8	17.2	19.4	20.1	21.3
	24	-0.3	5.4	9.6	12.9	15.8	18.2	20.3	21.4	22.3
	25	0.5	6.2	10.5	13.9	16.7	19.1	21.3	22.1	23.2
	26	1.3	7.1	11.4	14.8	17.6	20.1	22.3	23.1	24.2
	27	2.1	8.0	12.3	15.7	18.6	21.1	23.2	24.1	25.2
	28	3.0	8.8	13.2	16.6	19.5	22.0	24.2	24.9	26.2
	29	3.8	9.7	14.0	17.5	20.4	23.0	25.2	26.0	27.2
30	4.6	10.5	14.9	18.4	21.4	23.9	26.2	27.0	28.2	

* The calculation is based on Sonntag's equation.

* When the ambient relative humidity is above 85%, dew condensation will form on the cryopump case.

SERVICE NETWORK

- For technical support, servicing or additional contact information, visit us at www.ulvac-cryo.com.

ULVAC CRYOGENICS INC.

www.ulvac-cryo.com

1222-1 Yabata, Chigasaki, Kanagawa 253-0085, Japan

<Sales>

Tel: +81-467-85-8884

<Service Engineering Division>

Tel: +81-467-85-9366

Fax: +81-467-83-4838

ULVAC CRYOGENICS KOREA INC.

www.ulvac-cryo.co.kr

107, Hyeongoksandan-ro, Cheongbuk-Myeon, Pyeongtaek-si,
Gyeonggi-Do, Korea, 17812

Tel: +82-31-683-2926

Fax: +82-31-683-2956

ULVAC CRYOGENICS (NINGBO) INC.

www.ulvac-cryo.com

No.888 Tonghui Road, Jiangbei District, Ningbo, China, 315020

Tel: +86-574-879-03322

Fax: +86-574-879-10707

This page intentionally left blank.

Revision History

Date	Revision No.	Contents
2016-05-20	2016.05	First edition.
2017-08-31	2017AT01	“Service Network” has been revised.
2017-10-24	2017OR02	“1. Cryopump Description” “1.3 Environmental Requirements” has been added. “Appendix F Dew Condensation” has been added.
2022-05-27	2022MY03	“Service Network” has been revised. "Safety Instructions" has been revised.

This page intentionally left blank.