

COMPRESSOR UNIT

Instruction Manual

C15T

Export Control Policy

Vacuum pumps that pump nitrogen gas at pumping speed of 15000L/s or more fall under row 2(35) of appended table 1 of Japan's Export Trade Control Order, which is based on international export control regimes. Customers must follow all related rules and regulations such as Foreign Exchange and Foreign Trade Act and take appropriate procedures when exporting or re-exporting those products.

Introduction

Thank you for choosing our products. This instruction manual provides information and precautions on handling, installation, operation, and maintenance of the product.

To ensure proper use of the product, read this instruction manual carefully and keep this manual close at hand so that you can use for reference during operation.

If you have purchased other devices from us, read relevant instruction manuals carefully as well.

1. About the personnel who are involved in handling our products

All personnel involved in handling our products should take general safety training which is officially accepted in the country or region where the product is used. Such personnel are also required to have specialized knowledge, skills or qualifications on electricity, machinery, cargo handling or vacuum. Especially, the personnel should be familiar with handling a cryopump in order to use it safely. We offer training program (paid service) as needed for the customers who are not familiar with the use of cryopumps. Please contact us to join the program.

2. Warranty

2.1 Gratis warranty period and Warranty coverage

【Gratis warranty period】

The period of less than one year after installation in your company or your customer's premises, or a period of less than 18 months (starting from the shipment date) after shipment from ULVAC CRYOGENICS INCORPORATED (hereinafter "UCI"), which is shorter, is selected.

【Coverage】

(1) Failure diagnosis

As a general rule, first diagnosis of failure should be done on site by customer.

However, UCI or our service network can perform this service for an agreed fee upon the customer's request. There will be no charge if the cause of the breakdown is attributed to UCI.

(2) Damage during transportation

When damage by transportation is observed at the time of delivery, the product will be repaired without charge based on the scope of the guarantee expressed in the sales contract.

(3) Breakdown repairs

The cost of repairs, replacements and on-site visits for the failures caused by the reasons as follows shall be borne by the customer regardless the product is within the warranty period.

- ① Inappropriate storage or handling, careless accident, software or hardware design by the customer.
- ② Modifications of the product without consent of UCI.
- ③ Performing maintenance of the product using parts or components which are not approved by UCI, or using the product outside the conditions specified for the product.
- ④ Contamination or corrosion occurred during the use by the customer or customer's customer.
- ⑤ Fire, earthquake, flood, lightning or other natural disasters, environmental pollution, salt damage, hazardous gases, irregular voltage, and/or usage of power source other than specified by UCI.
- ⑥ Other reasons which are regarded to be outside the scope of warranty.
- ⑦ Consumables and/or replacement service.

Since the above services are limited inside Japan, diagnosis of failures, etc may not be performed outside of Japan. If you desire the after sale service abroad, please contact ULVAC CRYOGENICS and consult us for details in advance.

2.2 Exclusion of opportunity loss from warranty liability

Regardless of the gratis warranty term, compensation to opportunity losses incurred to your company or your customers by failures of ULVAC CRYOGENICS products and compensation for damages to products other than ULVAC CRYOGENICS products and other services are not covered under warranty.

2.3 Repair period after production is discontinued

ULVAC CRYOGENICS accepts product repairs for seven years after production of the product is discontinued.

3. Service Form

After the products are delivered, please fill out the following information in the blanks. In the event of a fault, please contact us. Refer to SERVICE NETWORK at the end of this book, or visit our web site at www.ulvac-cryo.com to locate our business base close by.

Cryopump/Super Trap Model	:	_____
Cryopump/Super Trap Serial No.	:	_____
Refrigerator Model	:	_____
Refrigerator Serial No.	:	_____
Compressor Model	:	_____
Compressor Serial No.	:	_____
Temperature controller/Thermal display Model	:	_____
Temperature controller/Thermal display Serial No.	:	_____
Optional Part Model	:	_____
Optional Part Serial No.	:	_____

4. Notes for repair and maintenance requests

We cannot accept your request for repair or maintenance of our products if you refuse to give us information about the presence of the hazardous substance and/or contaminant.

Also, please be aware that we do not accept liability for damages by the contaminant, which might be caused during transportation to our office or the nearest customer support center. To avoid such accident, please pay careful attention to packing of the product

5. In case of breakdown and accident

When breakdown or accident occurs, we may ask for keeping the product on site as it is, or sending it back to us to investigate the cause. In addition, you may be asked to provide information on how it progressed in a specific manner or on the

operating condition. When unidentified failure occurs, please contact our Service Engineering Division or the nearest customer support center. Refer to the SERVICE NETWORK at the end of this book or visit our website at www.ulvac-cryo.com for our contact information.

6. General Precautions

- (1) It is prohibited to duplicate or reprint this instruction manual or any of its parts, disclose or transfer to a third party without written permission from ULVAC CRYOGENICS.
- (2) Information in this document is subject to change without notice along with the specification change or the improvement of the product.
- (3) If you have any questions or comments on this document, please contact us.

Safety Icons and Texts

Our products have been designed to provide extremely safe and dependable operation when properly used. Following safety icons indicate cautions, warnings or danger that must be observed during normal operation and when servicing them.

**WARNING**

A warning describes safety hazards or unsafe practices which could result in severe injury or loss of life.

**CAUTION**

A caution describes safety hazards or unsafe practices which could result in personal injury or equipment damage.

**Toxic gas or chemicals used.**

There is a risk of severe injury upon contact.

**Corrosive chemicals used.**

There is a risk of severe injury upon contact.

**Flammable gas used.**

There is a danger of fire or burn injury.

**Explosive gas used.**

There is a risk of fire or explosion.

**Hazardous voltage.**

Electric shock may cause severe injury or loss of life.

**Hot heating part present.**

There is a risk of burn injury.

This page intentionally left blank

Table of Contents

Safety Instructions	S-1
Disposal Considerations	IW-1
1. COMPRESSOR UNIT DESCRIPTION	1-1
1.1 General	1-1
1.2 Specifications	1-1
2. INSPECTION	2-1
2.1 Shipping List	2-1
2.2 Inspect Compressor Unit	2-1
2.3 Inspect Flexible Hoses	2-2
2.4 Inspect Cables	2-2
3. INSTALLATION	3-1
3.1 Installation	3-1
3.2 Connecting Cooling Water Piping	3-2
3.3 Cooling Water	3-2
3.4 Connecting the Compressor Unit to the Cryopump	3-5
3.5 Connecting Electrical Cables	3-7
4. OPERATION	4-1
4.1 Before Operation	4-1
4.2 Normal Operation	4-1
5. DISCONNECTION AND STORAGE	5-1
5.1 Disconnecting Flexible Hose	5-1
5.2 Storage	5-2
6. MAINTENANCE	6-1
6.1 Scheduled and Unscheduled Maintenance	6-1
6.2 Adsorber Replacement	6-1
6.3 Charging Helium Gas	6-5
Appendix A Trouble Shooting	A-1
Appendix B Circuit Diagram	B-1
Appendix C Flexible Hose	C-1
Appendix D Flow Diagram	D-1
Service Network	CS-1

Figures

Figure 1-1	Dimensions	1-3
Figure 1-2	Major Components	1-4
Figure 1-3	Major Components (Controller)	1-5
Figure 3-1	Maintenance Space(Unit: mm)	3-1
Figure 3-2	Cooling Water Requirement	3-4
Figure 3-4	Charge Pressure and Temperature	3-5
Figure 3-3	Connecting Flexible Hose	3-6
Figure 3-4	Static Pressure and Temperature	3-7
Figure 3-5	Compressor Installation.....	3-8
Figure 5-1	Disconnecting Flexible Hose	5-2
Figure 6-1	Adsorber replacement.....	6-3
Figure B-2	C15T Wiring Diagram.....	B-5
Figure D-1	Flow Diagram	D-2

Tables

Table 1-1	Compressor Unit Standard Specifications	1-1
Table 2-1	Shipping List.....	2-1
Table 2-2	Optional Parts	2-1
Table 3-1	Recommended Cooling Water for Compressor.....	3-3
Table 3-2	Input Power Cable Specifications.....	3-8
Table A-1	Troubleshooting Procedures	A-1
Table A-2	Operating Log	A-3

Compressor Unit Safety Instructions

Read this manual and follow these safety guidelines before installing, operating, or servicing the compressor unit.

1. Do not overfill helium gas



Our cryopump and Super Trap refrigerator systems make a refrigeration cycle by circulating high pressure helium gas. Filling helium gas of more than appropriate amount does not improve refrigeration capacity appreciably. Instead, if too much helium gas is filled and helium pressure becomes higher than appropriate, helium will blow out from the pressure relief valve, which can be a cause of helium leak by dirt being stuck in the sheet. This may even overload the compressor motor.

Never charge helium gas more than specified in Table 1-1.

2. Adding helium gas and charging equipment

When charging helium gas or performing helium line decontamination, refer to the "Maintenance" section and follow the instruction.

The equipment (regulators, charging hoses, adopters, etc.) that can be used at the pressure of 2.0MPaG or higher are required to perform the above work.

3. Do not shutdown / startup operation frequently

Do not switch between ON and OFF frequently.

The number of startup and shutdown of the compressor motor must be less than 6 times per hour and ON or OFF state should be maintained for at least 3 minutes. Starting up and shutting down too frequently reduces the insulation life of compressor motor and may result in failure. When operating multiple refrigerators, the number of startup and shutdown of the refrigerator motors must be also 6 times or less per hour.

Do not use startup and shutdown to control the temperature of the Super Trap.

Please contact us when you need to control the Super Trap temperature.

4. Disposal of used adsorber



Ensure to discharge helium gas and remove either side of the self-sealing couplings from the used adsorber before disposing.

When the refrigerator system is not in operation, helium gas pressure inside the adsorber is as high as the charge pressure of the compressor. Disposing the adsorber with helium gas inside may cause accidents. For example, if the adsorber was thrown in a burner reactor without discharging helium gas by mistake, the inside pressure of the adsorber rises as the inside temperature rises and may result in explosion. If the adsorber was pressed with helium gas remaining inside, it may also cause explosion. Refer to “Disposal Consideration” for more information.

Use appropriate charging adaptor to remove helium gas safely.

5. Electrical wiring connections



- Power supply voltage must be kept within the allowable range (refer to “Section 1 Table1-1 Compressor Unit Standard Specifications”. Applying more than the allowable voltage may damage the equipment.
- Install a ground-fault circuit interrupter (rated current: 20A, rated tripping leakage current:30mA 3Ø, rated voltage: 200V).
- Grounding conductor (earth wire) must be connected. (D class grounding (with the ground resistance of 100Ω)).
- Connect the refrigerator cable and remote cables (signal lines) to the compressor before connecting the compressor to the power supply. These wiring connections must not be done when the compressor is powered on. It could lead to a serious accident such as electric shock and/or damage to the equipment.
- Follow recommended sizes for wires and cables.
- The distance between power line and signal line must be larger than 100mm.

6. Cooling water

Water leak may invite electric shock. Ensure there is no water leak from the cooling water piping. If the water pressure is too high, a leak may occur in the cooling water line inside the compressor unit. Adjust and control the cooling water supply pressure to maintain an allowable upper limit indicated in “Section 3 Figure 3-2 Cooling Water Requirement”

If water stain or some products accumulate in the water line inside the heat exchanger, heat exchange effectiveness will be significantly reduced and helium gas temperature will rise, this may shut down the compressor unit.

We employ the cooling water quality management standard of the Japan Refrigeration and Air Conditioning Industry Association as a standard value of water quality for compressor units. Please refer to “Section 3 Table 3-1 Recommended Cooling Water for Compressor”.

7. Ambient conditions of the compressor unit

The upper limit of the compressor operating ambient temperature is 38 °C. Do not use the compressor in unsuitable environments such as dusty, highly humid environments and/or places that are affected by strong electromagnetic waves. Keep electric terminals free from dust to avoid electrical leakage and/or a short circuit.

8. Maintenance precautions



1. Installation and maintenance of the product must be done by personnel in charge of the equipment or servicing who are familiar with the product structure and risk associated with the operation of the compressor.
2. Input power supply must be disconnected before opening the cover of the compressor to avoid the risk of electrical shock.

Also, parts inside the compressor unit are still hot immediately after shutdown. Wait at least 15 minutes to open the cover to avoid the risk of burn injury.

9. Contact us immediately when the self-sealing coupling is loosened.



When working with a self-sealing coupling, the connection may be accidentally loosened or loosened by co-rotation. In such cases, the refrigerator may encounter faults due to helium leakage or air invasion, resulting in serious failure such as abnormal noise or refrigerator motor malfunction.

At the time of shipment of our products, we conduct the inspection to ensure the connection of self-sealing coupling is appropriate and paste a sealing sticker. The sealing stickers are added to our refrigerators, compressor units, flexible hoses, branch pipes and straight pipe units.

Contact us when the self-sealing coupling is loosened or removed by accident. Servicing for trouble is out of warranty if it occurs while the sealing sticker is not in the original state.

The sealing sticker is located inside the panel of the compressor unit.

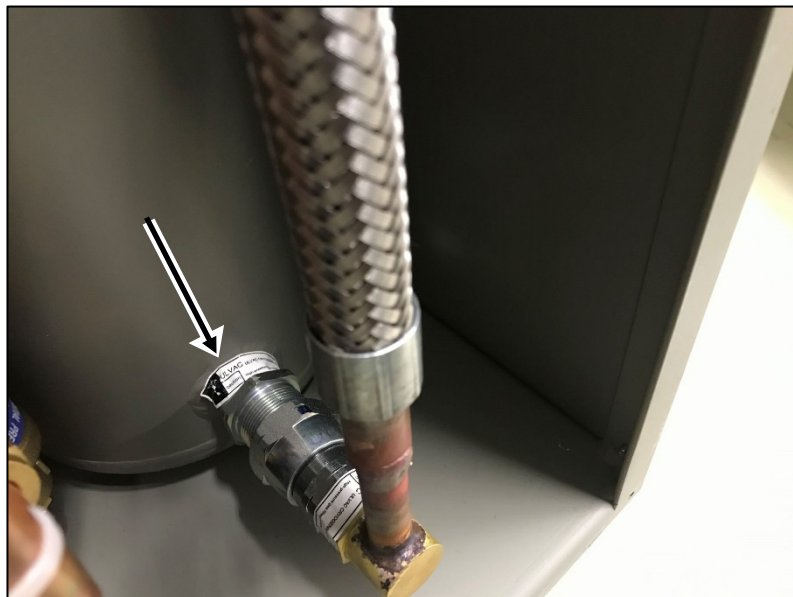







Figure Example of the sealing sticker pasted on the self-sealing coupling

Disposal Considerations

Disposal of our products must be done in accordance with applicable national and local laws and regulations.

				WARNING
<p>The cryopumps or cryocoolers may contain residue of hazardous substances resulting from actual use. Contact your safety supervisor and follow the instructions to remove such toxic substances before disposing</p>				

		WARNING
<p>Do not disassemble, pressurize, heat up a compressor unit, or throw it into fire. Such actions may lead to explosion of the adsorber inside the compressor unit. For safe disposal of an adsorber, follow the procedures below.</p> <ol style="list-style-type: none">(1) Remove high pressure helium gas inside the adsorber to reduce the internal pressure to the level of ambient atmospheric pressure. To do so safely, use tools appropriate to the adsorber coupling such as our charging adaptor (for cryocooler maintenance).(2) Remove the coupling to make it visible that the adsorber has been depressurized before proceeding to the next step.		

We provide Safety Data Sheet (called SDS) of our products upon your request.

Please contact us if necessary.

This page intentionally left blank.

1. COMPRESSOR UNIT DESCRIPTION

1.1	General	1-1
1.2	Specifications	1-1

1.1 General

The compressor unit supplies and circulates helium continuously in the cryopump system for operation of the refrigerator unit (coldhead).

The C15T compressor unit consists of: 1) compressor motor, 2) cooling system, 3) oil separation system and 4) adsorber.

See Table 1-1 for the standard compressor specifications.

1.2 Specifications

Table 1-1 Compressor Unit Standard Specifications

◆ Model : C15T

Power Source	Voltage x Phase x Frequency	190 - 220VAC x 3Φ x 50Hz 200 - 230VAC x 3Φ x 60Hz
	Power (in normal operation) (*1)	3.3kW / 4.1kW(50Hz/60Hz)
Cooling Type		Water cooled
Cooling Water Requirement (See Fig.3-2)		Temperature : 5 - 32°C Flow Rate : 2 - 6L/min Pressure Drop : 0.04 - 0.17MPa
Ambient Temperature		10 - 38°C
Compressor Winding Resistance		1.63Ω
Adsorber Replacement Cycle		30,000 hours
Current (normal operation)		13A (200V, 60Hz)
Weight		100kg
Cooling Water Inlet/Outlet		Rc3/8 female
Helium Gas SUPPLY/RETURN Connector		1/2B self-sealing coupling

(*1) The power consumption shows the figure when flexible hose of 3m is used and helium charge pressure is 1.60MPaG. The power consumption is higher by 10% for 5 minutes from the startup.

◆ Helium Gas Pressure: (Room temperature : 20°C)

Charge Pressure(*1)	1.60±0.04 MPaG
Operating Pressure (*2) SUPPLY side	1.7 – 1.9 MPaG

(*1) The charge pressure may slightly vary depending on the length of flexible hose.

Refer to Chapter 3.4 and adjust the pressure based on the flexible hose length.

(*2) The figure shows the pressure at normal cooling down operation. The pressure may slightly differ than the table above immediately after the startup. The pressure is 1.7MPaG for 30 seconds from the startup as bypass operation takes place inside the compressor unit.

◆ Applicable Model of Cryopump

CRYO-U10H, U10HL, U10PU, U10PU-S, U10HSP
CRYO-U12H, U12HSP, U12HL (*3)

(*3) For 12-inch models of cryopump, the C15T compressor unit can be used only when the load is light.

◆ Connector Specifications

CONNECTOR	MANUFACTURER	TYPE
INPUT POWER	NANABOSHI	NCS-304-P
COLD HEAD POWER CABLE	NANABOSHI	NJC-204-PM
METAL CONNECTOR (For external signal, remote response)	JAE	SRCN6A25-16P

◆ Dimensions

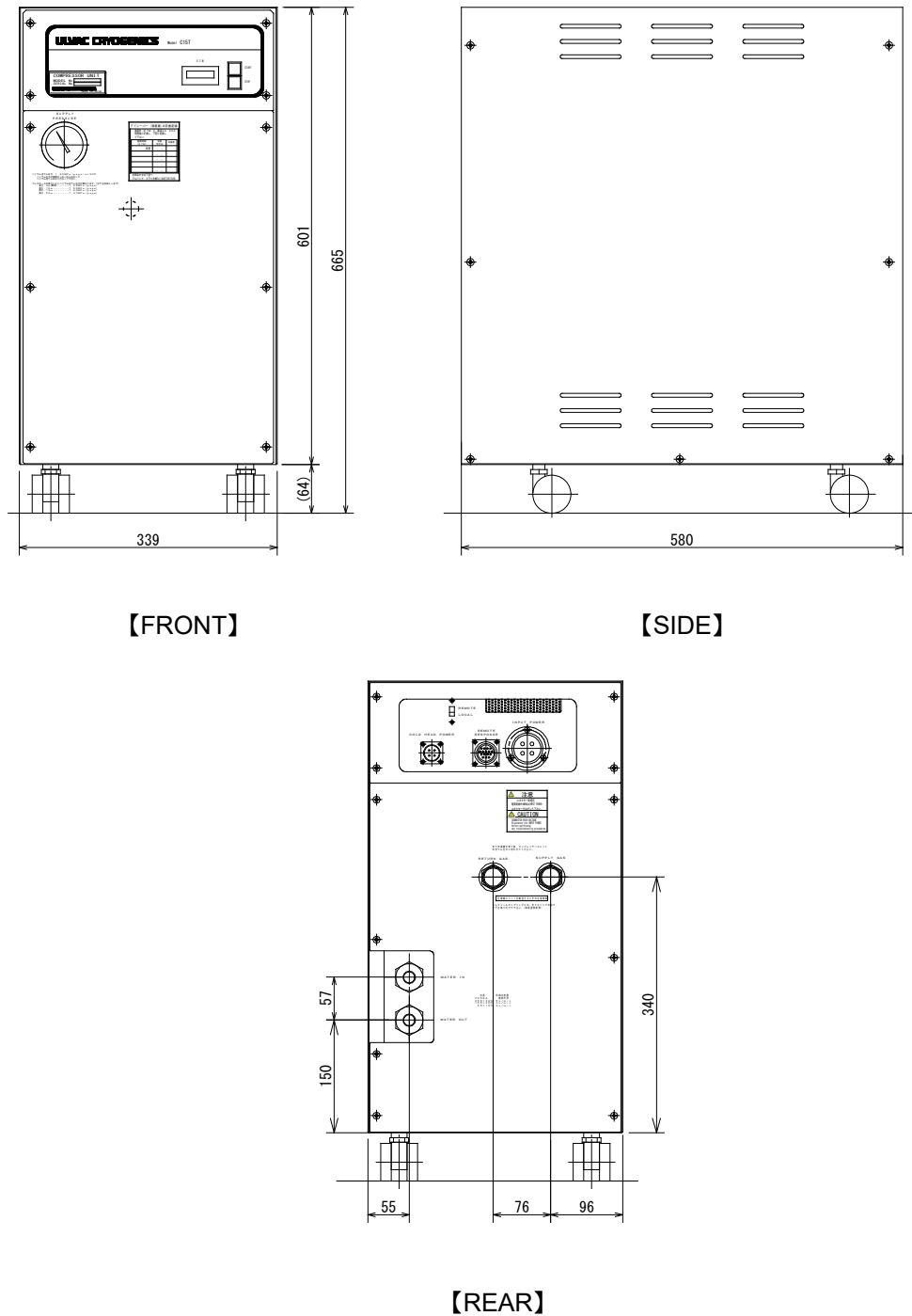

Figure 1-1 Dimensions

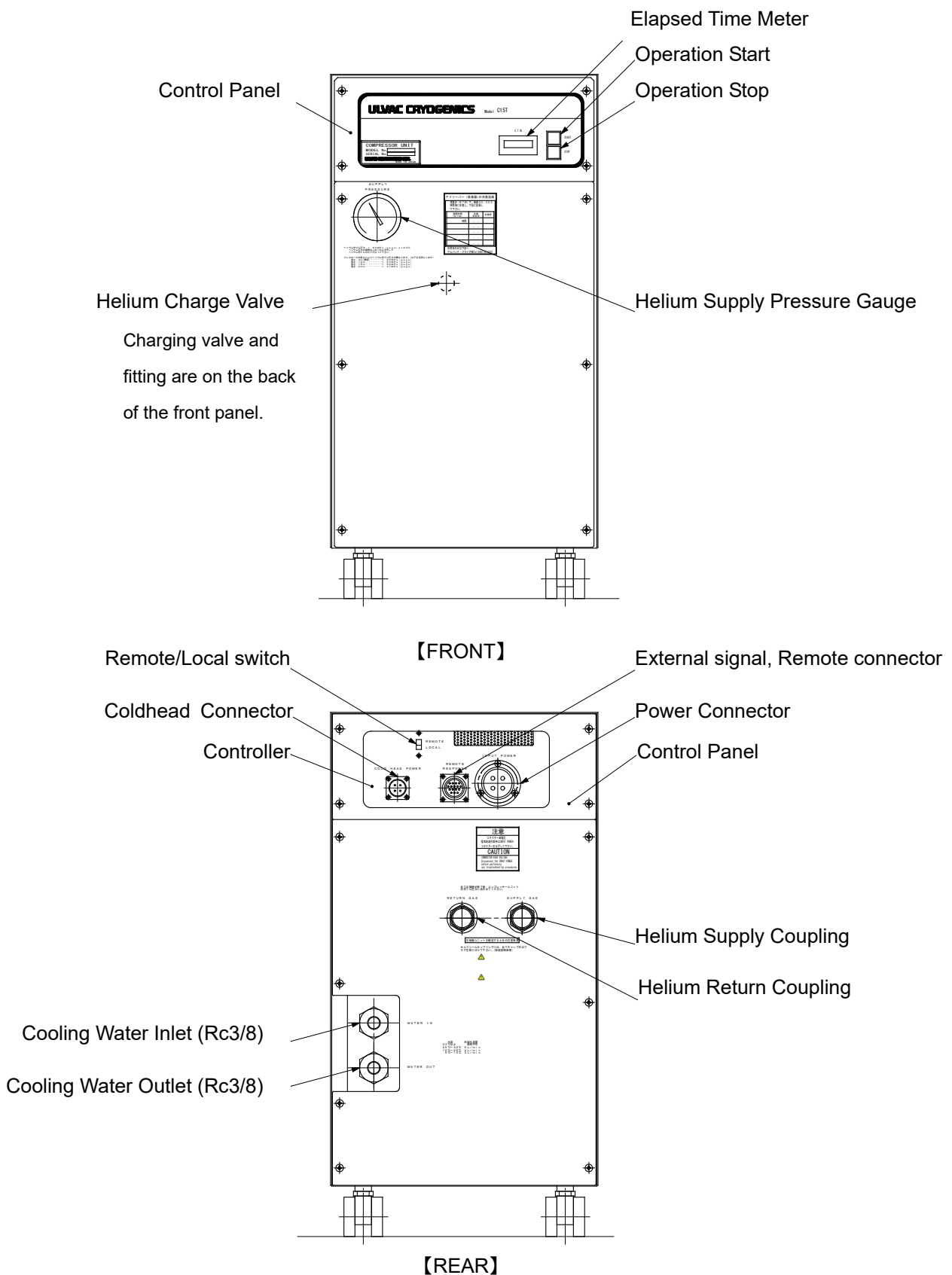
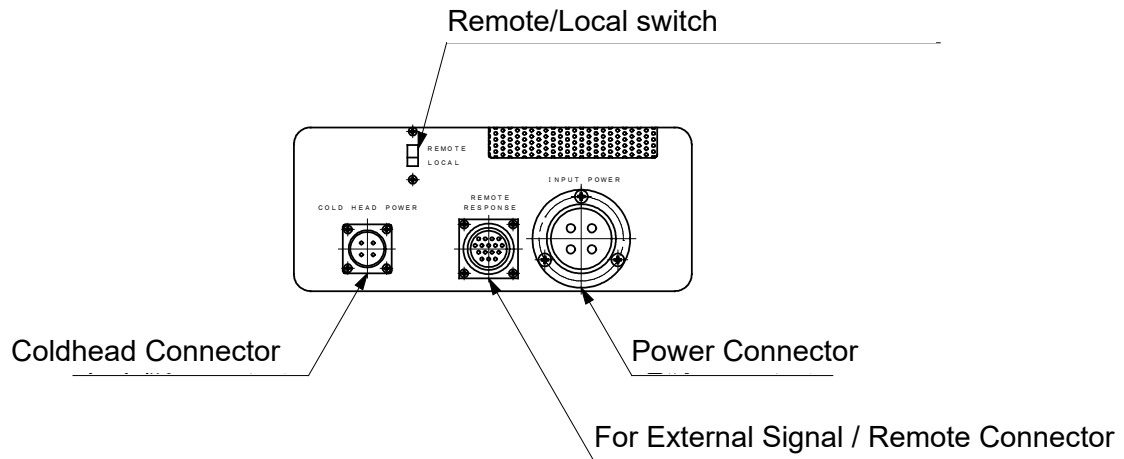
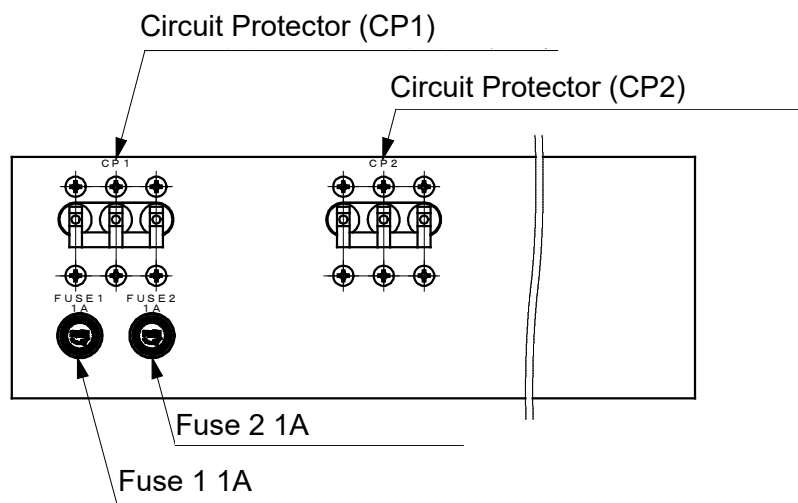

Figure 1-2 Major Components

◆ CONTROLLER (REAR)



◆ CONTROLLER (SIDE)



*Remove the control panel on the rear to operate switches on the side of the controller.

Figure 1-3 Major Components (Controller)

This page intentionally left blank.

2. INSPECTION

2.1	Shipping List	2-1
2.2	Inspect Compressor Unit	2-1
2.3	Inspect Flexible Hoses.....	2-2
2.4	Inspect Cables	2-2

2.1 Shipping List

Inspect the compressor for visible sign of damage. Also, refer to the shipping list enclosed in the carton and check that the items on the list are present. Depending on your specification, the optional part(s) in Table 2-2 is attached.

Table 2-1 Shipping List

Item	Quantity
Compressor Unit	1
Instruction Manual (This book)	1
Fuse(250V,1A)	1
Metal Connector (External signal, Remote)	1

Table 2-2 Optional Parts

Item	Quantity
Input Power Cable (5.5mm ² x 4cores x 3m or customized length)	1
Coldhead power cable (0.5mm ² x 4cores x 3m or customized length)	1
Flexible Hose (3m or customized length)	2
Lipped Bowl Spanner (for attaching flexible hoses)	2
Gasket for Helium Coupling(Spare)	4

2.2 Inspect Compressor Unit

Check helium charge pressure on the pressure gauge on the front panel. When charging helium is required, refer to chapter 6.3 for the procedure.

If the pressure drops even after charging helium, please contact us.

2.3 Inspect Flexible Hoses



CAUTION

- Do not bend flexible hoses in a way that damages them, or with the bend radius smaller than 250mm. Failure to observe this precaution may result in damage to the flexible hose.
- Prevent twisting at the connection.
- Refer to Appendix C for more information on handling of the flexible hoses.

Inspect the exterior of the flexible hose for twists or tear.

When the flexible hoses are stored or not being used, put dust caps and plugs on as they were shipped.

2.4 Inspect Cables

Inspect the cables for damage.

If you find any missing parts or damages of the product, please contact us.

3. INSTALLATION

3.1	Installation.....	3-1
3.2	Connecting Cooling Water Piping.....	3-2
3.3	Cooling Water	3-2
3.4	Connecting the Compressor Unit to the Cryopump.....	3-5
3.5	Connecting Electrical Cables.....	3-7

3.1 Installation

1. Place the compressor unit on a level floor within 5°.
2. The compressor unit must be operated in proper room temperature (10°C - 38°C).
Avoid dust and moist.
3. Leave the spaces as shown in Figure 3-1 for easier maintenance processes including;
 - Pressure gauge inspection.
 - Gas charge valve operation.
 - Adsorber replacement.

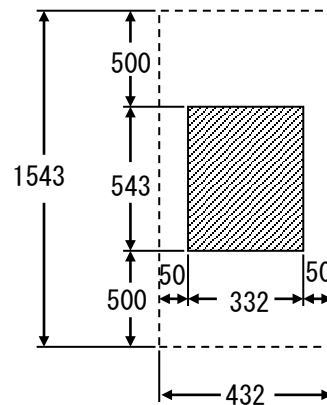

Figure 3-1 Maintenance Space(Unit: mm)

3.2 Connecting Cooling Water Piping

Install the cooling water piping as follows:

1. Cooling water inlet/outlet connector: Rc3/8 female.
2. Water pipes should be made of materials with pressure resistance of larger than 1.5 times of the cooling water inlet such as plastic or copper.
3. It is recommended that a filter is installed in the water line between the cooling water main valve and the compressor unit to prevent water scales. It is also recommended to install a flow meter (approx.0 - 15L/min.) between the filter and the compressor unit to check the flow rate.
4. Ensure to connect inlet/outlet to the right place. Do not connect them the wrong way around.



CAUTION

Check water connections for leaks.

3.3 Cooling Water

1. Determine the cooling water flow rate within the allowable range as shown in Fig. 3-2. Always use the proper cooling water that meets the requirement. Keep the cooling water supply pressure less than 0.7MPaG.



CAUTION

- If the temperature of cooling water is below 5°C, it can cause overloading or a difficulty in starting the compressor.
- If the temperature of cooling water is higher than 32°C, the thermal switch will be activated due to the overheat and turn off the compressor.
- Excessive flow rate reduces the life of heat exchanger.

2. For the standard quality of cooling water, we refer to the water quality control standard set by The Japan Refrigeration and Air Conditioning Industry Association.



CAUTION

- Usage of poor quality water causes performance degradation of heat exchanger.
- If the water quality does not satisfy the requirement, it shortens the lifetime of the heat exchanger.

Table 3-1 Recommended Cooling Water for Compressor

Item	Unit	Allowable Range
pH (25°C) ^{※1}	pH	6.5 - 8.0
Conductivity (25°C) ^{※1}	mS/m	< 30
Chloride Ion, Cl ⁻ ^{※1}	mg / L	< 50
Sulfate Ion, SO ₄ ²⁻ ^{※1}	mg SO ₄ ²⁻ / L	< 50
Acid Consumption (pH4.8) ^{※1}	mgCaCO ₃ / L	< 50
Total Hardness ^{※1}	mgCaCO ₃ / L	< 50
Total Carbonic Acid ^{※1}	mg/ L	< 10
Calcium Carbonate	mg/ L	< 75
※1 The values of the items are based on the water quality management standards of Japan Refrigeration and Air Conditioning Industry Association.		

(*) The ground water may contain large amount of total carbonic acid and lower the pH value. If the ground water flows in one-way, corrosion of heat exchanger may occur in a short-term. It is recommended to use cooling water with total carbonic acid density of lower than 10mg/L. Since the dissolved ratio of total carbonic acid depends on the temperature and the pressure, analyze the ground water immediately before exposing to the atmosphere. Check the water supply whether it is from ground water or not before use. It is highly recommended to use cooling tower to circulate the water containing a large amount of carbonic acid.

3. Stop supplying cooling water when the compressor is not running. If normal water supply is done while the device is suspended, it may result in clog or corrosion of pipe and heat exchanger.



CAUTION

Stop cooling water flow when the water temperature is below 10°C. If cooling water of below 10°C keeps flowing while the compressor is not in operation, the compressor may fail to startup due to increased viscosity of lubricating oil.

Cooling water must be drained from the compressor unit when:

- Cooling water may freeze when the compressor unit is not running. The water pipe can burst.
- The compressor unit will be suspended for longer than a week.
- Shipping the compressor unit.

Most of the cooling water can be drained by 30 seconds of blowing air with inlet pressure of 0.2MPaG and outlet opened to the air

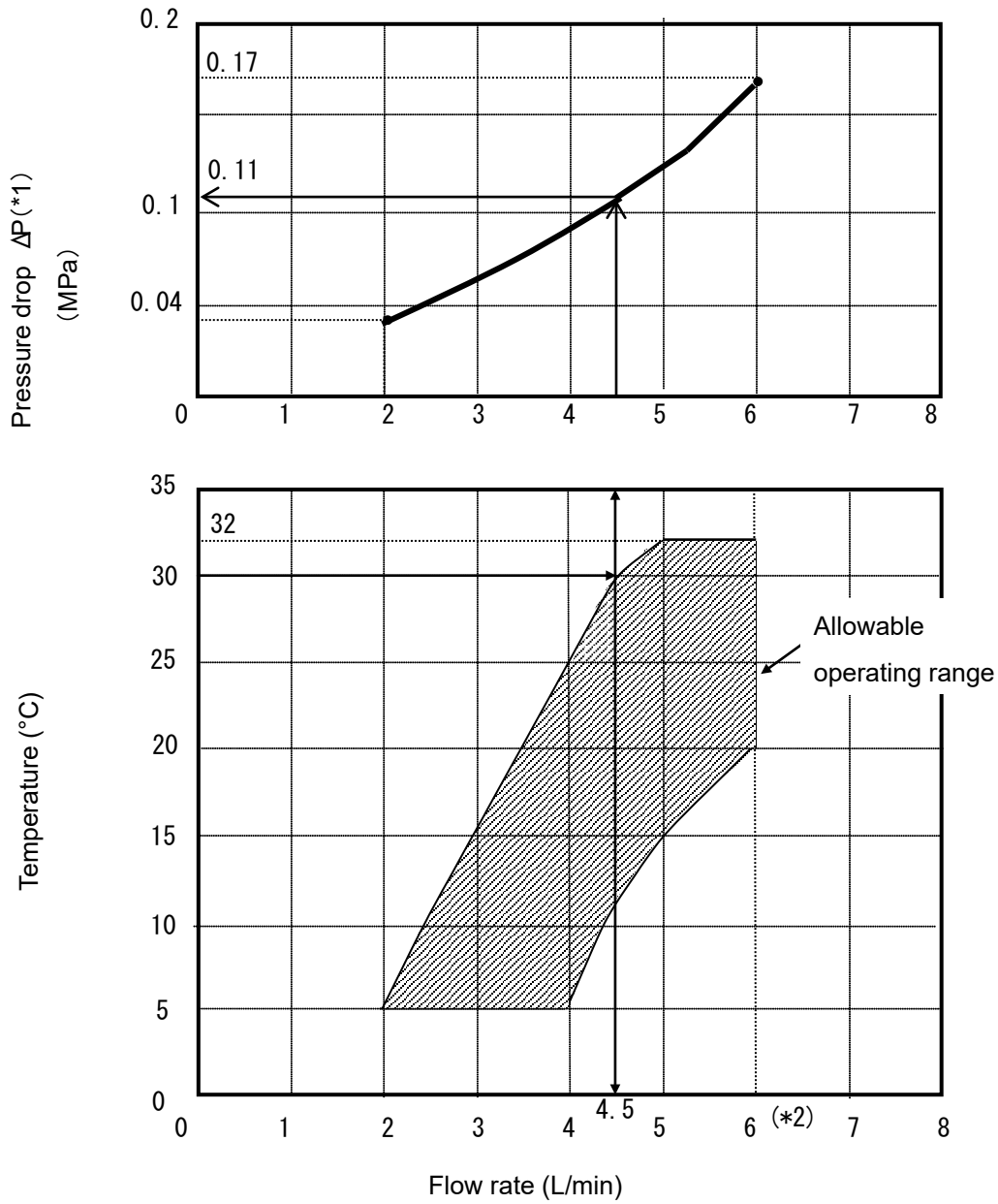

(*1) Water pressure drop (ΔP) refers to the differential pressure between cooling water inlet and outlet.

(*2) Water flow rate should be below 6.0L/min to prevent corrosion of heat exchanger.

EXAMPLE
 A dashed arrow (\rightarrow) in the above graph shows the water flow rate and pressure (ΔP) required when the water temperature is 30°C. Water flow rate is 4.5L/min and water pressure (ΔP) is 0.1MPa.

Figure 3-2 Cooling Water Requirement

3.4 Connecting the Compressor Unit to the Cryopump



CAUTION

- Read the handling notes in appendix C about the connection of the flexible hoses.
- When connecting flexible hoses, always use two single open end spanners with width across flat 26mm and 30mm.
- Do not forcibly bend flexible hoses. They may be damaged and cause helium leakage.
- Do not connect or disconnect self-sealing coupling frequently. It may cause helium leakage .

1. Remove all dust plugs and caps from the supply and return flexible hoses, compressor and cryopump. Clean the self-sealing coupling flat rubber gasket to be free from dust and metallic powder.
2. Connect the flexible hose from the compressor unit to the cryopump (See Figure 3-4) .
 - a. Connect the helium gas supply flexible hose labeled SUPPLY to the helium gas supply connector on the compressor. Then connect the other end of the hose to the SUPPLY GAS port on the cryopump (coldhead).
 - b. Connect the helium gas return flexible hose labeled RETURN to the helium gas return connector on the compressor. Then connect the other end of the hose to the RETURN GAS port on the cryopump (coldhead).

3. Check helium charge pressure.

Standard helium charge pressure is 1.60 ± 0.04 MPaG at 20°C. See Figure 3-3.

If the indicated pressure is higher than appropriate, allow a slight amount of helium gas to escape by opening the gas charge valve **very slowly**.

If indicated pressure is lower than appropriate, add helium gas as described in section 6.3.

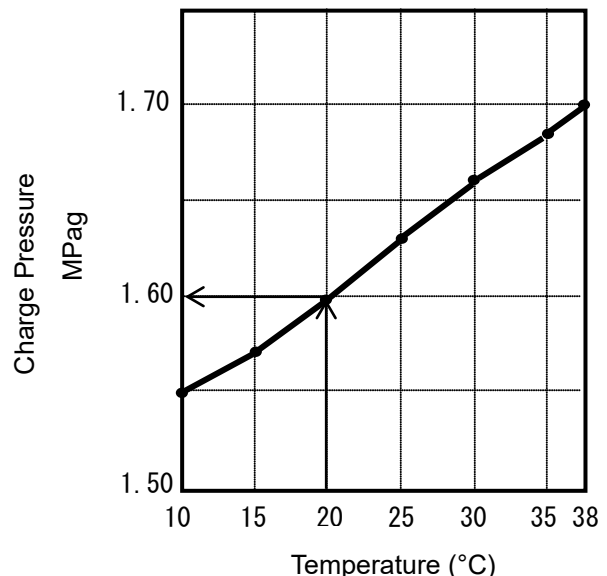

Figure 3-3 Charge Pressure and Temperature

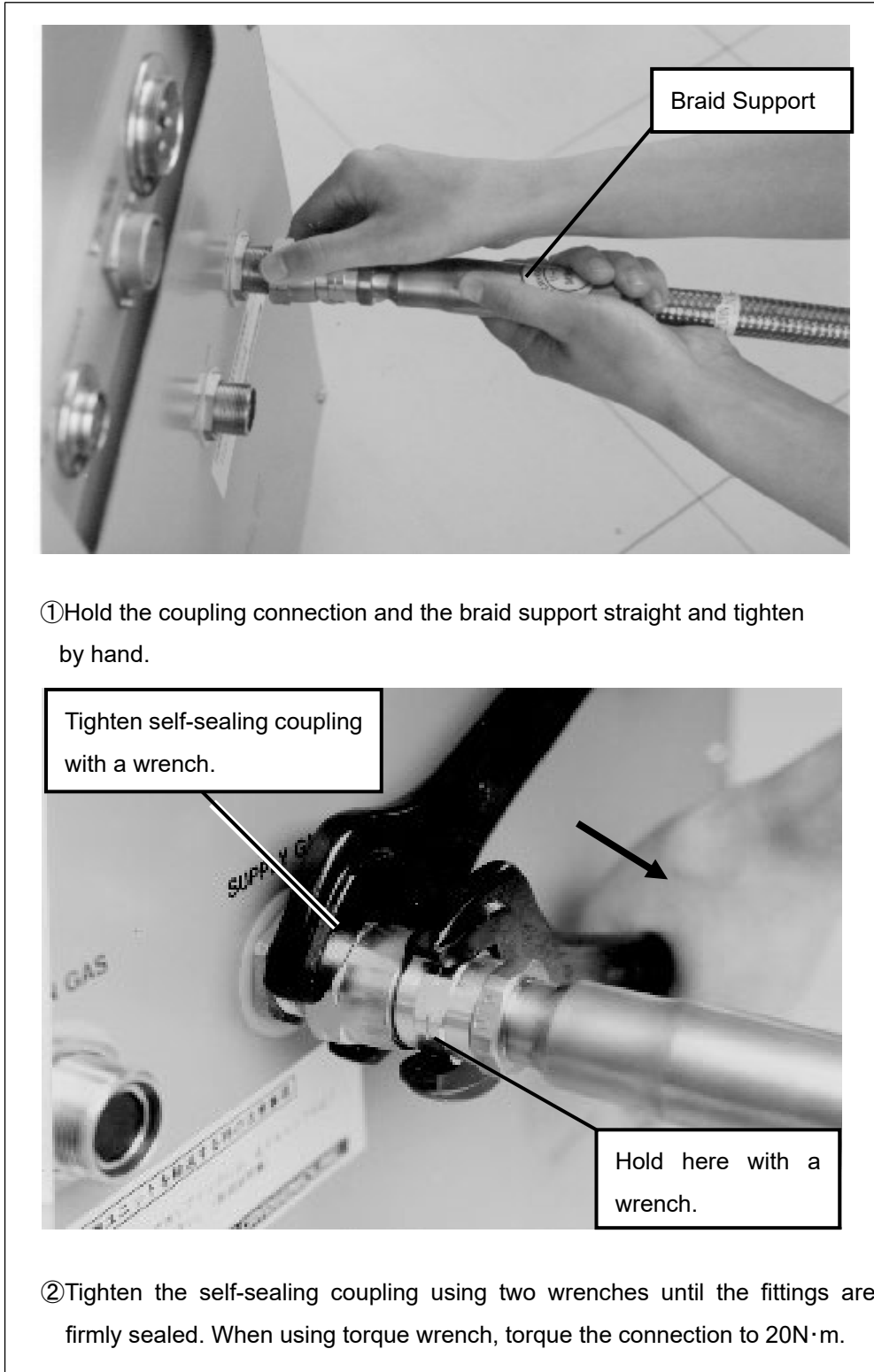

Figure 3-4 Connecting Flexible Hose



CAUTION

- Do not operate the compressor with excess helium (static charge pressure 1.65MPaG or above at room temperature 20°C) to improve reliability.
- The operating pressure tend to be higher with flexible hoses of 3 meters or longer.

The charge pressure for different hose length is as follows;

<Flexible Hose Length>	<Charge Pressure>
3 meters (standard)	1.60MPaG
10 meters	1.53MPaG
15 meters	1.50MPaG
20 meters	1.47MPaG

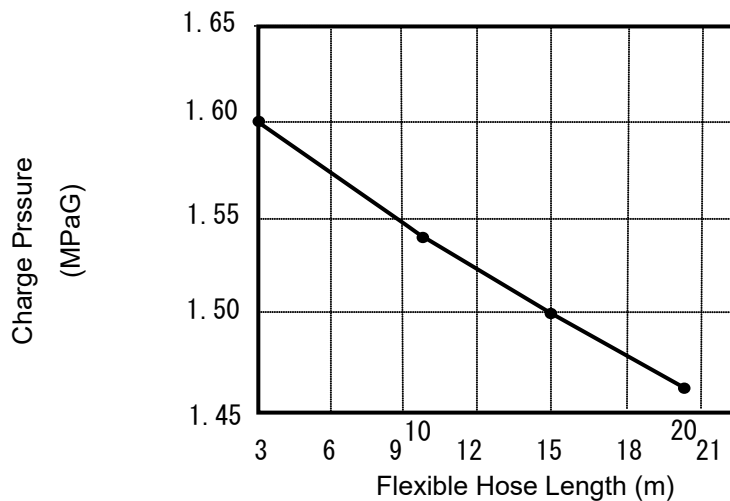

3.5 Connecting Electrical Cables



WARNING

Do not connect the compressor to power supply until all wiring and connections are completed.

1. Make the REMOTE/RESPONSE wiring, if necessary.



WARNING

Disconnect the input power connector at REMOTE/RESPONSE wiring. Failure to observe this precaution could result in damage to, or destruction of, the equipment.

- ◆ **REMOTE WIRING** :Set the REMOTE/LOCAL switch to 「REMOTE」 position.
Make the REMOTE wiring according to the circuit diagram shown in Appendix B. Always use the momentary switch (contact) for setting START/STOP push button switch (PB1, PB2) in remote operation.
- ◆ **RESPONSE WIRING** :Be sure to make wiring for RESPONSE signals. The relay specification of response signals is shown in Appendix B.

2. Connect the refrigerator power cable from the compressor to the cryopump.
3. Connect the ground.
4. Connect the connector side of the input power cable to the compressor.
Connect the other side of the input power cable to the power source.

Note : If customer-supplied input power cable is used, be sure that it is equivalent to UCI-supplied cable.

Table 3-2 Input Power Cable Specifications

Item	Symbol	Specifications
Input power cable	INPUT POWER	Copper wire / 600VAC, 3 conductors with ground ^(*) 1.25mm ²

(*) The color of the ground wire is green.

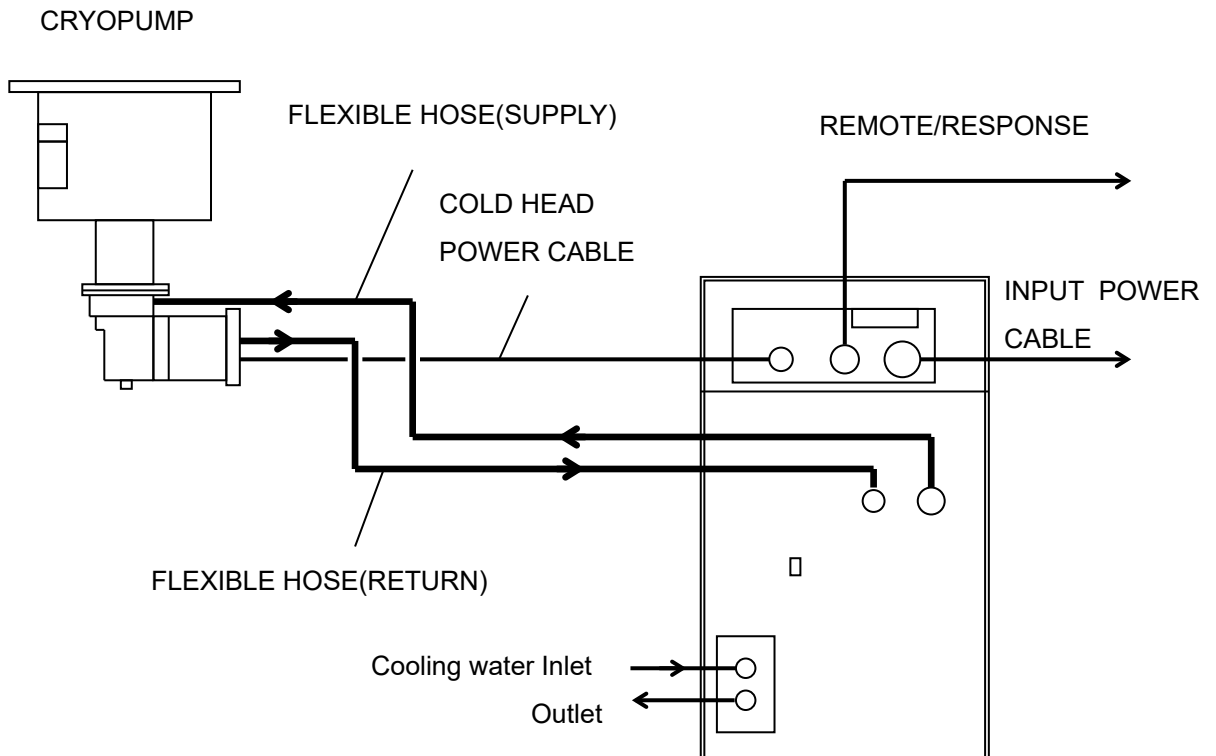

Figure 3-5 Compressor Installation

4. OPERATION

4.1	Before Operation	4-1
4.2	Normal Operation	4-1

4.1 Before Operation

Before operating the compressor, check following items;

1. The power supply meets the requirements described in Table 1-1.
2. STOP switch lights up when the power is supplied to the compressor.
If it does not light, the phase may be reversed. Change any one set of RST phases.
3. REMOTE/LOCAL switch is properly set.
4. Connectors are fixed firmly.
5. Cooling water meets the requirements.
6. Helium gas static pressure is within the appropriate values.

4.2 Normal Operation



CAUTION

Check that the operating pressure is within the values shown in Table 1-1.

Helium pressure while the compressor is in operation varies depending on the length of the flexible hoses. Especially, helium pressure tends to be high when flexible hose is longer than 3m. Adjust the pressure by releasing helium from helium charge port.

This page intentionally left blank.

5. DISCONNECTION and STORAGE

5.1	Disconnecting Flexible Hose	5-1
5.2	Storage.....	5-2

5.1 Disconnecting Flexible Hose



CAUTION

When disconnecting flexible hoses, be sure to use two single open end spanners with width across flat 26mm and 30mm.

1. Shut down the compressor unit.
2. After the Super Trap and/or cryopump (refrigerator unit) has been warmed up to room temperature, disconnect the flexible hoses.



CAUTION

- If flexible hoses are disconnected while the cryocooler is still in low temperature, the pressure inside the cryocooler will rise as it warms up, resulting in helium leakage by activated pressure relief valve.
- Note that when performing helium circuit decontamination of the refrigerator unit, it is required to disconnect the flexible hoses at the compressor unit side immediately after shutdown.

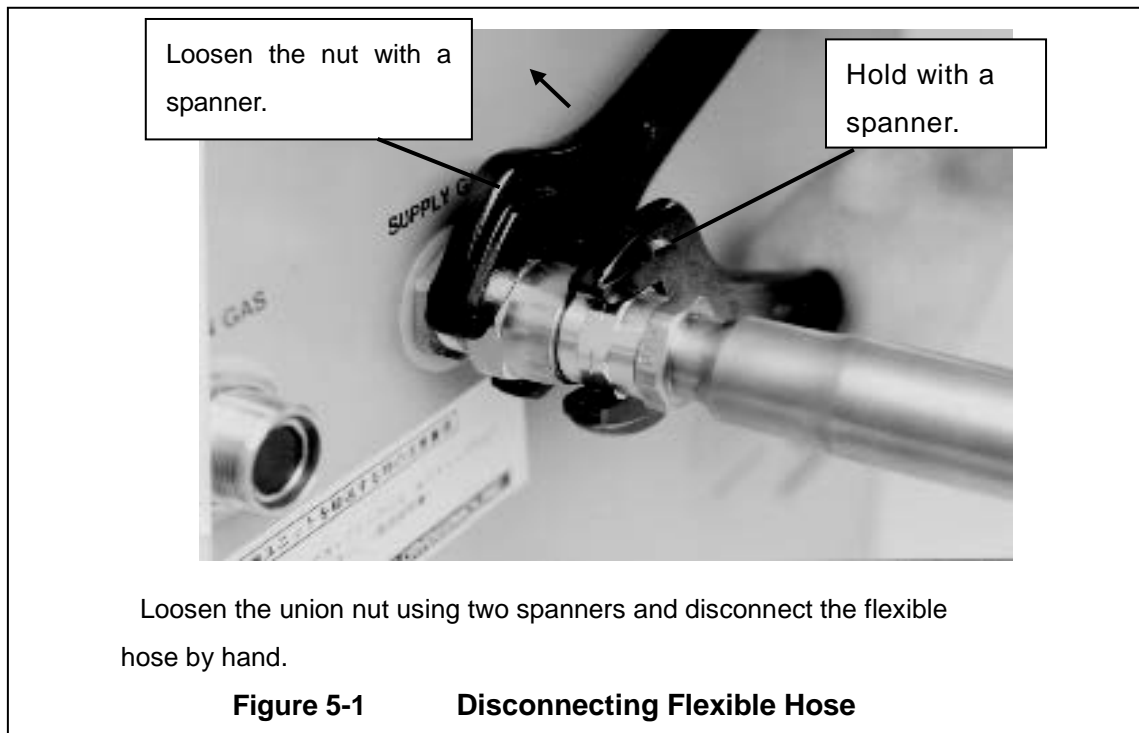

5.2 Storage

- ◆ Follow the instructions below to store the compressor unit.
 1. Disconnect the flexible hoses. Refer to Section 5.1.
 2. Disconnect cables and cooling water piping. Cooling water must be purged from the compressor unit. Refer to Section 3.3.
 3. Put the protective caps back on the helium gas connectors and cover the compressor unit with plastic sheet as they were shipped.
 4. Avoid direct sunlight, heat, humidity, vibration, radiation, dust, wind and rain.
 5. The compressor unit should be placed on level floor (within $\pm 5^\circ$) and fixed not to move and/or fall.
 6. Check the pressure gauge of the compressor unit periodically. Contact our Service Engineering Division or the nearest customer support center if the pressure keeps lower. There is a possibility that a leakage might have occurred.

- ◆ When the compressor unit is to be suspended for more than three months, follow the instructions below in addition to the above.
 - Operate the compressor unit for about an hour every three months to circulate lubricating oil to prevent the damage caused by the lack of the oil when starting the compressor unit again after long-term storage.

- ◆ When shipping the compressor unit, pack in the same way as at the time of shipment and avoid excess impact.

This page intentionally left blank.

6. MAINTENANCE

6.1.	Scheduled and Unscheduled Maintenance.....	6-1
6.2.	Replacement of Adsorber	6-1
6.3.	Charging Helium Gas	6-5

	 WARNING
<p>Always disconnect the compressor from all sources of electrical power before performing any maintenance procedures.</p>	

6.1 Scheduled and Unscheduled Maintenance

◇Scheduled Maintenance : Replacement of the adsorber (after every 30,000 hrs)

◇Unscheduled Maintenance : Adding helium gas

6.2 Adsorber Replacement

One of the scheduled maintenance required on the compressor is the replacement of the adsorber within every 30,000 hours. Use more than 30,000 hours cause to be a machine trouble on refrigerator unit. Keep to remove and replace the adsorber proceed within every 30000 hours as following procedures:

◆Removing the Adsorber

1. Close the main valve of high vacuum system.
2. Shut down the refrigerator unit and the compressor unit.
3. Switch off the primary power.
4. Disconnect the flexible hoses from gas-return and gas-supply connectors at the rear of the compressor.
5. Remove the jam nuts holding the self-sealing coupling (male) .(Figure 6-1 (1))
6. Remove the rear panel from the compressor by unscrewing 7 screws.(Figure 6-1 (1))
7. Disconnect the flexible hose from the adsorber inlet. (Figure 6-1 (2))

**CAUTION**

When disconnecting and reconnecting the self-sealing coupling, always use two spanners as described in Section 3.4 and 5.1.

8. Remove the adsorber mounting bolt (M6). (Figure 6-1 (3))
9. Remove the adsorber from the compressor. (Figure 6-1 (4))

**WARNING**

Depressurize the adsorber before disposing of it.

Always use the charging adapter to depressurize the adsorber.

◆ Installing the Adsorber

1. Remove the dust caps from the self-sealing coupling halves at each end of the replacement adsorber.
2. Install the replacement adsorber following the steps for adsorber removal in reverse order.
3. Connect the adsorber to the compressor internal piping.
4. Ensure that the helium pressure gauge reads 1.60 ± 0.04 MPaG. If additional gas pressure is required, follow the instructions in Section 5.1.
5. Replace the rear panel.
6. Write installation date and elapsed time on the adsorber label. Also write elapsed time for the next replacement of adsorber (plus 30000 hours to the present elapsed time).



- (1) Remove the jam nuts.
Loosen the seven bolts to
remove the rear panel.



- (2) Disconnect flexible hose from
the adsorber inlet.



- (3) Remove the adsorber
mounting bolt.



- (4) Draw the adsorber out of the
compressor unit.

Figure 6-1 (1) Adsorber replacement

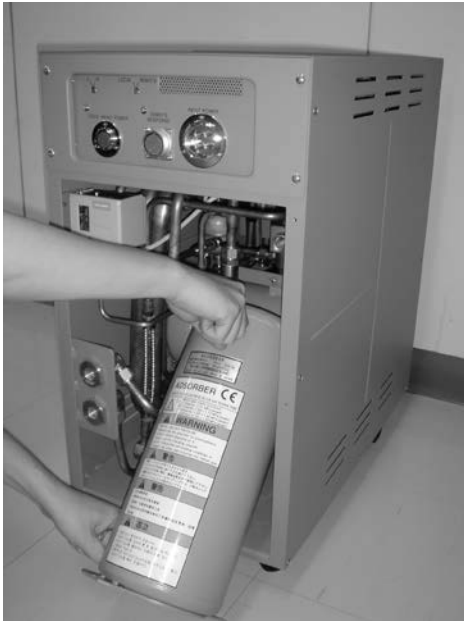

- Tilt the adsorber to take out from the compressor.
Use cautions not to touch the piping.

RECORD SHEET OF THE ADSORBER REPLACEMENT

Replace the adsorber after a maximum operation of 30,000 hours. Write the elapsed-time of the meter (ETM) on this sheet.

Elapsed-Time Hours	Replaced Date	Person Replaced
Hr.	. .	
	. .	
	. .	
	. .	
	. .	

INQUIRY: ULVAC CRYOGENICS, INC
Tel. (0467) 85-0303

- (5) Install the replacement adsorber following the removal steps in reverse order.
- (6) Record the elapsed time on the label.

Figure 6-1 Adsorber replacement (2)

6.3 Charging Helium Gas

Equipment for charging helium gas (regulators, charging hoses, adapters) that can be used at 2.0MPaG or above are required.



CAUTION

If the helium pressure gauge of the compressor unit shows 0 MPaG, contamination caused by air or moisture may occur in the system. If it occurs, contact our Service Engineering Division or customer support center.

When helium gas pressure reduces, it is necessary to add helium gas. Clarify the cause of the pressure reduction before adding helium gas. If there is a leakage, take an adequate measure before charging. Improperly connected self-sealing coupling might be one of the causes of the leakage.

- ◇ It is recommended to use the regulator which shows the range of 4-6 MPaG as outlet pressure.
- ◇ The gas charge inlet of the compressor unit is 1/4B male flare.
- ◇ Use helium gas with purity of 99.999% or above.

Follow the steps below to add helium gas;

1. When mounting the regulator on a new helium bottle, perform the following procedures in order to purge the air and fill helium gas in the gas line between the regulator and the bottle valve.
 - a. Open the regulator a little. The regulator can be opened commonly by turning the handle clockwise.
 - b. Slowly open the bottle valve, and purge the air in the gas line for several seconds.
 - c. Close the regulator. (Normally by rotating counterclockwise)



CAUTION

If the bottle valve is opened ignoring the above step 1, the air between the regulator and the bottle valve diffuses into the helium bottle and deteriorates the purity of helium gas.

2. Remove the front panel of the compressor unit.
3. Connect the helium charging hose as follows:

- a. Connect the charging hose to the regulator.
 - b. Loosely connect the charging hose to the charge inlet on the compressor unit.
 - c. Open the regulator until the return side pressure reaches 0.1 - 0.2 MPaG. Allow helium gas to flow out from the charging hose for about 30 seconds. Meanwhile, open the charge valve slightly in order to drive out the air that exists between the charge valve and the charge inlet.
 - d. Tighten the flair nut at the end of charging hose and close the charge valve. Helium gas charge in the line between the regulator and the charge valve on the compressor has been completed.
4. Adjust the low pressure side of the regulator at 1.8 MPaG.
 5. Open the charge valve slowly and follow the instruction below based on the state of the compressor.
 - a. If the compressor unit is running under normal operating conditions, replenish it with the pure helium gas until it reaches the operation pressure described in the compressor instruction manual.
 - b. If the compressor unit is not running, replenish it with the pure helium gas until it reaches the static pressure described in the compressor instruction manual.

**CAUTION**

If helium gas has been charged more than 1.9MPaG, the pressure relief valve on the refrigerator may work. Charge helium gas slowly to prevent the pressure relief valve from being activated. The pressure relief valve inside the compressor unit is set at 2.5MPaG.

6. Close the charge control valve after charging helium gas.
7. Close the regulator and remove the charging hose from the charge inlet.

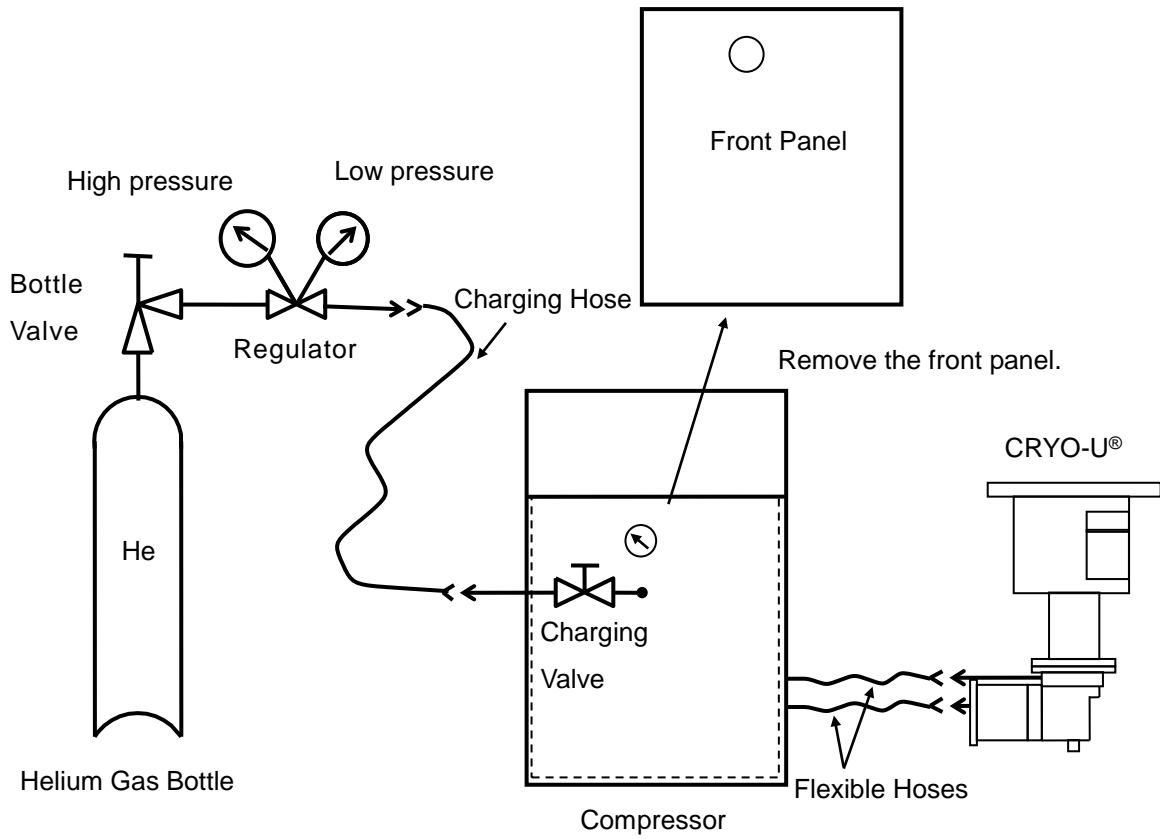

Figure 6-2 Charging Helium Gas

This page intentionally left blank

Appendix A

TROUBLESHOOTING



			WARNING
<ul style="list-style-type: none"> ◆ Disconnect the compressor from its power source before performing any troubleshooting procedures. ◆ The compressor pump is hot after operating. Wait for the unit to cool down before working on the inside of the compressor. 			

Table A-1 Troubleshooting Procedures

No	Problems	Possible Cause	Corrective Action
I	Compressor does not startup.	1) No power coming from the source.	Check wiring and ensure that the power supply connector is connected properly.
		2) Circuit protectors (CP1, CP2) are OFF.	Set circuit protector to ON. (See Fig.1-3)
		3) Phase reverse relay (PRR) is active. (STOP lamp lights off)	Interchange 2 phases of primary power. (Refer to Section 4.1)
II	Compressor stops during continuous operation.	1) Thermal protective switch (TS3) is ON.	Check the cooling water condition (temperature, flow rate). (See Fig.3-2).
		2) Circuit protectors (CP1, CP2) or thermal relay (OL) are active.	Check the power supply voltage. Contact our Service Engineering Division or the nearest CS center. (The cooling water temperature and the room temperature will be needed.)
		3) Thermal protective switches (TS1 and TS2) are ON.	Contact our Service Engineering Division or the nearest CS center.

III	Compressor stops after operating several minutes	1) Thermal protective switch (TS3) is ON.	Check that the cooling water is flowing and its flow rate. (See Fig.3-2)
		2) Low pressure switch (LPS) is ON.	Add helium gas till the static pressure.
		3) Circuit protectors (CP1, CP2) or thermal relay (OL) are active.	Check the power supply voltage. Contact our Service Engineering Division or the nearest CS center. (The cooling water temperature and the room temperature will be needed.)
		4) Thermal protective switches (TS1 and TS2) are active.	Contact our Service Engineering Division or the nearest CS center.
		5) Compressor failure.	Contact our Service Engineering Division or the nearest CS center.
IV	Compressor makes abnormal noise during operation.	Helium charge pressure is too high.	Check helium charge pressure. The pressure must not exceed 1.65MPaG (at room temperature of 20°C).

This page intentionally left blank.

Appendix B

CIRCUIT DIAGRAM

◆ Safety Devices (inside of the controller)

	Name	Function and specification
OL	Thermal relay (AUTO RESET)	This relay is set up in the controller and automatically stops the compressor if the current flowing in the compressor is higher than specified value due to overloading, etc. STOP pushing button (PB1) lights up. <ul style="list-style-type: none"> • Rated current: 14A
CP1	Circuit protector (MANUAL RESET)	This device shuts off power if any line in the compressor circuitry is shorted. <ul style="list-style-type: none"> • Rated current: 25A
CP2	Circuit protector (MANUAL RESET)	This device shuts off power if any line in the refrigerator circuitry is shorted. <ul style="list-style-type: none"> • Rated current: 1A
PRR	Reverse phase protective relay	This relay does not allow the compressor to start when the compressor power wires are connected reverse phase.

◆ Safety Devices (outside of the controller)

	Name	Function and specification
TS1	Thermal switch	This switch automatically stops the compressor if the oil flow rate is insufficient or the compressor is overloaded. STOP push button (PB1): lights-out
TS2	Thermal switch	This switch is set up on the top of compressor and automatically stops the compressor if the compressor pump temperature is excessively high due to overloading, etc. STOP push button (PB1): lights-out
TS3	Thermal switch	This switch stops the compressor if there is no cooling water supply or cooling water temperature is excessively high. STOP push button (PB1): lights-out

—	Safety valve	This valve is set up in the helium supply line and automatically opens when the pressure is higher than static value. Set pressure: 2.85MPaG (413psig)
—	Differential pressure regulating valve	This valve is set up in the helium line between helium supply and return. The valve keeps the difference of pressure at the constant pressure rate. Set pressure: 1.60MPa
LPS	Low pressure switch	This switch stops the compressor when the pressure drops below a set value (due to leakage, etc.). Set pressure: 0.1 ± 0.03 MPaG
SOL	Solenoid valve	This valve opens when the compressor is turned off.

◆ Electrical equipment function

	Name	Function and specification
PB1 (PL1)	STOP push button switch (Momentary)	Press to turn off the compressor and coldhead. When the compressor unit is suspended while being connected to the power supply, this switch lights ORANGE.
PB2 (PL2)	START push button switch (Momentary)	Press to turn on the compressor unit. The STOP switch turns off and the START switch lights GREEN. The compressor unit normally starts operation.
SW1	REMOTE/LOCAL switch	Depends on your selection, START/STOP of the compressor operation and ON/OFF of the refrigerator operation by a remote location or switching of the compressor unit. Need to connect with REMOTE/external signal connector when you select a remote location.
SW2	L/H switch	This switch is set to H position at factory default. (If the cryopump has too much vibration, set this switch to L position to reduce. Note that this only works out with 50Hz.)
ETM	Elapsed time meter	This meter displays the elapsed operating hours of the compressor unit.
MR	Momentary power failure restart relay	<ul style="list-style-type: none"> • Momentary power cut shorter than 2 seconds -> Compressor automatically restarts after power restored • Momentary power cut longer than 2 seconds -> Not restart

CR1	Output signal relay to control the unit	<p>Turn ON or OFF START(PB2) and STOP(PB1) button to activate this relay to operate compressor unit including refrigerator.</p> <p>The C contact of this relay works to take out output signal of START and STOP via output signal or remote connectors.</p> <p>The following table shows the specification of the relay cont-act.</p> <p style="text-align: center;">CONTACT SPECIFICATIONS</p> <table border="1" data-bbox="600 573 1350 853"> <tr> <td data-bbox="600 573 943 618">Maximum voltage</td> <td data-bbox="943 573 1150 618">AC250V</td> <td data-bbox="1150 573 1350 618">DC125V</td> </tr> <tr> <td data-bbox="600 618 943 663">Maximum current</td> <td data-bbox="943 618 1150 663">5A</td> <td data-bbox="1150 618 1350 663">5A</td> </tr> <tr> <td data-bbox="600 663 943 801" rowspan="2">Rated load</td> <td colspan="2" data-bbox="943 663 1350 707">Resistance load (Induction load)</td> </tr> <tr> <td colspan="2" data-bbox="943 707 1350 801">AC220V 5A (2A) DC 24V 5A (2A)</td> </tr> <tr> <td data-bbox="600 801 943 853">Minimum applicable load</td> <td colspan="2" data-bbox="943 801 1350 853">DC5V 1mA</td> </tr> </table>	Maximum voltage	AC250V	DC125V	Maximum current	5A	5A	Rated load	Resistance load (Induction load)		AC220V 5A (2A) DC 24V 5A (2A)		Minimum applicable load	DC5V 1mA	
Maximum voltage	AC250V	DC125V														
Maximum current	5A	5A														
Rated load	Resistance load (Induction load)															
	AC220V 5A (2A) DC 24V 5A (2A)															
Minimum applicable load	DC5V 1mA															
CR2	Solenoid valve (SOL) relay	This relay is ON when the compressor is powered on.														
TM1	OFF delay timer	This timer delays restarting the compressor for 5 seconds from shutdown until it reaches to the restart prevent overloading.														
TM2	ON delay timer	This timer delays restarting the compressor for 5 seconds to prevent overloading.														
TM3	On delay timer for SOL	After the compressor unit is set up, this timer keeps the solenoid valve OPEN for 30 seconds to prevent overloading.														

This page intentionally left blank.

Appendix C

FLEXIBLE HOSE

1. Specifications

- Gas : Helium Gas (Purity of 99.999% or above)
- Pressure : Maximum 2.45MPaG

<Note> The content of “Specifications and Drawings” specific to your system supersedes, if provided.

- Temperature : 0 to 70°C
- Material : SUS304
- Length : 3000mm (standard)
- Minimum Bending Radius : 250mm
- Recommended Torque for Connecting : 20N·m

<Note> Fasten the self-sealing coupling until fully tight.

- Connection : 1/2B self-sealing coupling

2. Handling Precautions



CAUTION

- When carrying a flexible hose, hold the braid support of the hose. Bending the flexible part forcibly at an acute angle may damage the hose.
- Do not twist a flexible hose especially when making continuously bent connections.
- Keep away from water and salt to prevent corrosion. Do not place heavy objects on flexible hoses in order to prevent deformation or collapse.

This page intentionally left blank

Appendix D

FLOW DIAGRAM

Low pressure helium gas returning from the refrigerator unit enters the compressor. Lubricant oil is injected into the compressor with the low pressure helium; the gas containing the oil is then compressed by the compressor pump turning it into high temperature high pressure helium gas. Most of the lubricant oil returns to droplet form and is separated within the compressor. This lubricant oil is pooled at the bottom and lubricates the inside of the compressor. It follows the circulating system where it comes out from the compressor and cooled down at an oil heat exchanger before being injected back into the compressor through an oil injection filter.

High temperature high pressure helium gas comes out from the compressor, passes through a water cooled helium heat exchanger for removal of compression-caused heat. It is cooled to an ambient temperature and then enters an oil separator. In here, the oil is separated and the droplets of separated oil pass thorough an oil return filter and oil return orifice before joining the low pressure helium gas and being returned to the compressor. High pressure helium gas comes out from the oil separator enters an adsorber where oil-mist is adsorbed and removed. The Helium gas comes out the adsorber passes through a flexible hose and is supplied to the refrigerator unit.

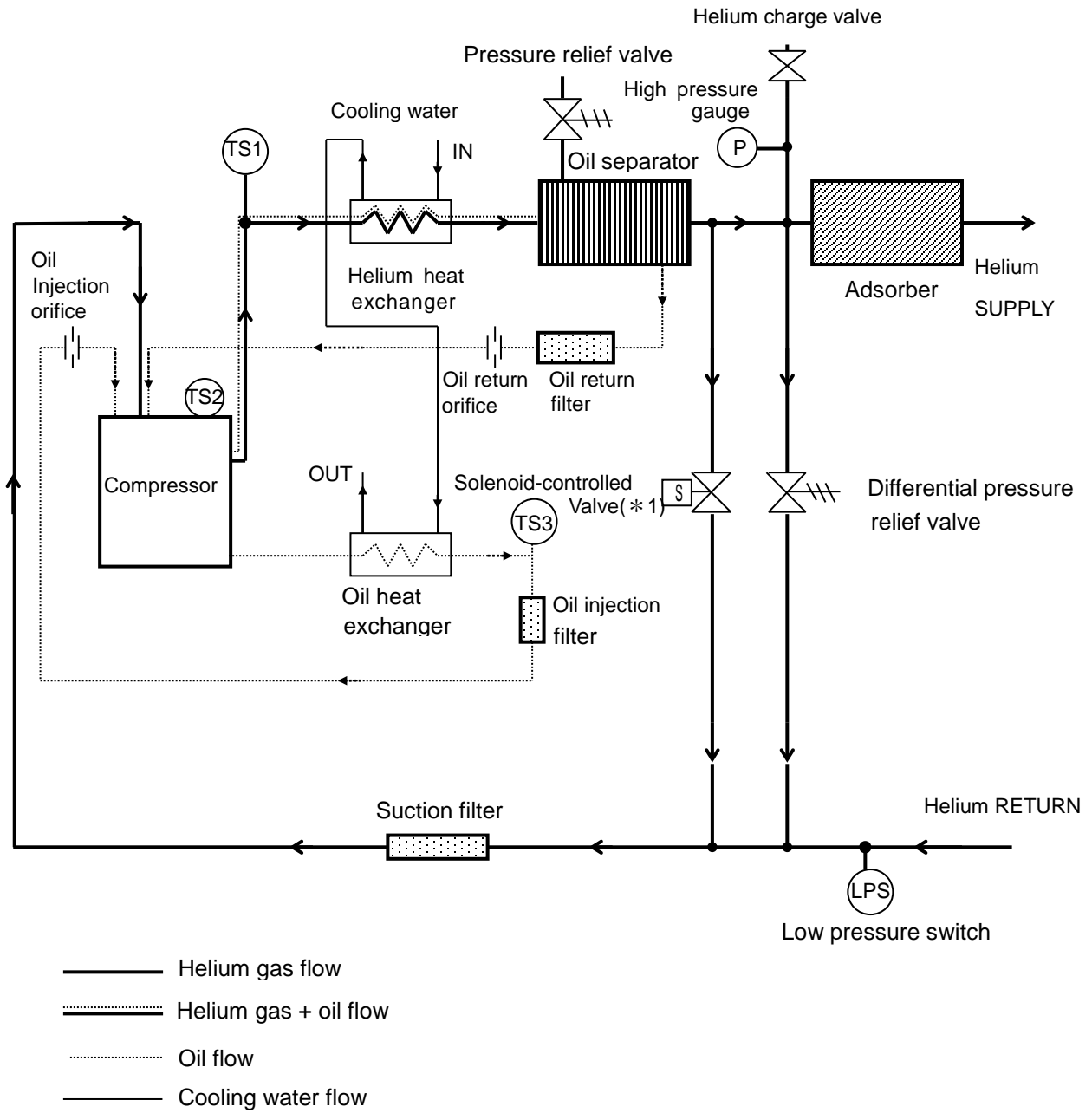

(* 1): Open when the compressor unit is in operation.

Figure D-1 C15T Flow Diagram

SERVICE NETWORK

- For technical support, servicing or additional contact information, visit us at www.ulvac-cryo.com.

ULVAC CRYOGENICS INC.

www.ulvac-cryo.com

1222-1 Yabata, Chigasaki, Kanagawa 253-0085, Japan

<Sales>

Tel: +81-467-85-8884

<Service Engineering Division>

Tel: +81-467-85-9366

Fax: +81-467-83-4838

ULVAC CRYOGENICS KOREA INC.

www.ulvac-cryo.co.kr

107, Hyeongoksandan-ro, Cheongbuk-Myeon, Pyeongtaek-si,
Gyeonggi-Do, Korea, 17812

Tel: +82-31-683-2926

Fax: +82-31-683-2956

ULVAC CRYOGENICS (NINGBO) INC.

www.ulvac-cryo.com

No.888 Tonghui Road, Jiangbei District, Ningbo, China, 315020

Tel: +86-574-879-03322

Fax: +86-574-879-10707

This page intentionally left blank.

Revision History

Date	Revision No.	Contents
2020/01/16	2020.01	First edition.
2020/09/29	2020SR01	Appendix B. P.B-5/B-6 Circuit Diagram has been modified.
2023/10/24	2023OR02	“Safety Instructions” Description on the adsorber disposal has been modified. 6.3 Description on pressure relief valve has been modified. Appendix B Safety Devices has been modified. Appendix C A note has been added to flexible hose allowable pressure.

This page intentionally left blank.