

COMPRESSOR UNIT

Instruction Manual

C30PZ

Export Control Policy

Vacuum pumps that pump nitrogen gas at pumping speed of 15000L/s or more fall under row 2(35) of appended table 1 of Japan's Export Trade Control Order, which is based on international export control regimes. Customers must follow all related rules and regulations such as Foreign Exchange and Foreign Trade Act and take appropriate procedures when exporting or re-exporting those products.

Introduction

Thank you for choosing our products. This instruction manual provides information and precautions on handling, installation, operation, and maintenance of the product.

To ensure proper use of the product, read this instruction manual carefully and keep this manual close at hand so that you can use for reference during operation.

If you have purchased other devices from us, read relevant instruction manuals carefully as well.

1. About the personnel who are involved in handling our products

All personnel involved in handling our products should take general safety training which is officially accepted in the country or region where the product is used. Such personnel are also required to have specialized knowledge, skills or qualifications on electricity, machinery, cargo handling or vacuum. Especially, the personnel should be familiar with handling a cryopump in order to use it safely. We offer training program (paid service) as needed for the customers who are not familiar with the use of cryopumps. Please contact us to join the program.

2. Warranty

2.1 Gratis warranty period and Warranty coverage

【Gratis warranty period】

The period of less than one year after installation in your company or your customer's premises, or a period of less than 18 months (starting from the shipment date) after shipment from ULVAC CRYOGENICS INCORPORATED (hereinafter "UCI"), which is shorter, is selected.

【Coverage】

(1) Failure diagnosis

As a general rule, first diagnosis of failure should be done on site by customer.

However, UCI or our service network can perform this service for an agreed fee upon the customer's request. There will be no charge if the cause of the breakdown is attributed to UCI.

(2) Damage during transportation

When damage by transportation is observed at the time of delivery, the product will be repaired without charge based on the scope of the guarantee expressed in the sales contract.

(3) Breakdown repairs

The cost of repairs, replacements and on-site visits for the failures caused by the reasons as follows shall be borne by the customer regardless the product is within the warranty period.

- ① Inappropriate storage or handling, careless accident, software or hardware design by the customer.
- ② Modifications of the product without consent of UCI.
- ③ Performing maintenance of the product using parts or components which are not approved by UCI, or using the product outside the conditions specified for the product.
- ④ Contamination or corrosion occurred during the use by the customer or customer's customer.
- ⑤ Fire, earthquake, flood, lightning or other natural disasters, environmental pollution, salt damage, hazardous gases, irregular voltage, and/or usage of power source other than specified by UCI.
- ⑥ Other reasons which are regarded to be outside the scope of warranty.
- ⑦ Consumables and/or replacement service.

Since the above services are limited inside Japan, diagnosis of failures, etc may not be performed outside of Japan. If you desire the after sale service abroad, please contact ULVAC CRYOGENICS and consult us for details in advance.

2.2 Exclusion of opportunity loss from warranty liability

Regardless of the gratis warranty term, compensation to opportunity losses incurred to your company or your customers by failures of ULVAC CRYOGENICS products and compensation for damages to products other than ULVAC CRYOGENICS products and other services are not covered under warranty.

2.3 Repair period after production is discontinued

ULVAC CRYOGENICS accepts product repairs for seven years after production of the product is discontinued.

3. Service Form

After the products are delivered, please fill out the following information in the blanks. In the event of a fault, please contact us. Refer to SERVICE NETWORK at the end of this book, or visit our web site at www.ulvac-cryo.com to locate our business base close by.

Cryopump/Super Trap Model	:	_____
Cryopump/Super Trap Serial No.	:	_____
Refrigerator Model	:	_____
Refrigerator Serial No.	:	_____
Compressor Model	:	_____
Compressor Serial No.	:	_____
Temperature controller/Thermal display Model	:	_____
Temperature controller/Thermal display Serial No.	:	_____
Optional Part Model	:	_____
Optional Part Serial No.	:	_____

4. Notes for repair and maintenance requests

We cannot accept your request for repair or maintenance of our products if you refuse to give us information about the presence of the hazardous substance and/or contaminant.

Also, please be aware that we do not accept liability for damages by the contaminant, which might be caused during transportation to our office or the nearest customer support center. To avoid such accident, please pay careful attention to packing of the product

5. In case of breakdown and accident

When breakdown or accident occurs, we may ask for keeping the product on site as it is, or sending it back to us to investigate the cause. In addition, you may be asked to provide information on how it progressed in a specific manner or on the

operating condition. When unidentified failure occurs, please contact our Service Engineering Division or the nearest customer support center. Refer to the SERVICE NETWORK at the end of this book or visit our website at www.ulvac-cryo.com for our contact information.

6. General Precautions

- (1) It is prohibited to duplicate or reprint this instruction manual or any of its parts, disclose or transfer to a third party without written permission from ULVAC CRYOGENICS.
- (2) Information in this document is subject to change without notice along with the specification change or the improvement of the product.
- (3) If you have any questions or comments on this document, please contact us.

Safety Icons and Texts

Our products have been designed to provide extremely safe and dependable operation when properly used. Following safety icons indicate cautions, warnings or danger that must be observed during normal operation and when servicing them.

**WARNING**

A warning describes safety hazards or unsafe practices which could result in severe injury or loss of life.

**CAUTION**

A caution describes safety hazards or unsafe practices which could result in personal injury or equipment damage.

**Toxic gas or chemicals used.**

There is a risk of severe injury upon contact.

**Corrosive chemicals used.**

There is a risk of severe injury upon contact.

**Flammable gas used.**

There is a danger of fire or burn injury.

**Explosive gas used.**

There is a risk of fire or explosion.

**Hazardous voltage.**

Electric shock may cause severe injury or loss of life.

**Hot heating part present.**

There is a risk of burn injury.

This page intentionally left blank

TABLE OF CONTENTS

Safety Instructions	S-1
Disposal Consideration	IW-1
SECTION 1 Compressor unit Description	
1.1 Introduction	1-1
1.2 Specifications	1-2
SECTION 2 Inspection	
2.1 Shipping List	2-1
2.2 Compressor Unit	2-2
2.3 Connecting Pipings (Flexible Hoses)	2-2
2.4 Cables	2-2
SECTION 3 Installation	
3.1 Installation	3-1
3.2 Connecting Cooling Water Piping	3-1
3.3 Cooling Water	3-2
3.4 Connecting the Super Trap(Refrigerator unit) to the Compressor Unit	3-5
3.5 Connecting Electrical Cables	3-7
SECTION 4 Operation	
4.1 Power-on Procedure	4-1
4.2 Parameter Settings	4-2
4.3 Pre-operation Check	4-5
4.4 Normal Operation	4-6
4.5 DIP Switch Settings	4-6
SECTION 5 Disconnection and Storage	
5.1 Disconnecting Flexible Hoses	5-1
5.2 Storage	5-2
SECTION 6 Maintenance	
6.1 Scheduled and Unscheduled Maintenance	6-1
6.2 Replacement of Adsorber	6-1
6.3 Charging Helium Gas	6-3
APPENDIX	
A Troubleshooting	A-1
B Control	B-1

C Flexible Hose.....C-1
 D Flow Diagram.....D-1

FIGURES

Figure 1-1 Dimensions.....1-5
 1-2 Components and Locations.....1-6
 3-1 Maintenance Space.....3-1
 3-2 Cooling Water Requirement.....3-3
 3-3 Connecting Flexible Hose.....3-6
 3-4 Static Pressure and Temperature.....3-7
 3-5 C30PZ Connections.....3-8
 4.1 Refrigerator Operation.....4-2
 4.2 DIP Switch Default Position.....4-7
 5.1 Disconnecting Flexible Hoses.....5-2
 6-1 Charging Helium Gas.....6-5
 B-1 REMOTE Wiring Diagram.....B-3
 B-2 RESPONSE Wiring Diagram.....B-4
 B-3 FAILURE OUT Wiring Diagram.....B-5
 B-4 C30PZ Electric Circuit Diagram.....B-7/8
 D-1 C30PZ Flow Diagram.....D-2

TABLES

Table 1-1 Compressor Unit Standard Specifications.....1-2
 1-2 Components Descriptions.....1-9
 2-1 Shipping List.....2-1
 2-2 Optional parts.....2-1
 3-1 Recommended Cooling Water for Compressor.....3-2
 4-1 Alarm Codes at Power-on Procedure.....4-1
 4-2 Parameters List.....4-3
 4-3 Alarm Codes List.....4-4
 4-4 DIP Switch Functions.....4-6
 A-1 Troubleshooting Fault Diagnosis.....A-1
 A-2 Operating Log.....A-2
 B-1 REMOTE/RESPONSE Description.....B-2
 B-2 FAILURE Out Description.....B-5

Compressor Unit Safety Instructions

Read this manual and follow these safety guidelines before installing, operating, or servicing the compressor unit.

1. Do not overfill helium gas



Our Cryo-U® cryopump and Super Trap refrigeration systems make a refrigeration cycle by circulating high pressure helium gas. Charging helium gas more than appropriate amount does not improve refrigeration capacity. Instead, if excessive helium gas is filled and pressure becomes higher than the appropriate value, gas will release from the safety valve and its sheet may become clogged with dust. This may even cause leakage as well as overload the compressor motor.

Never charge helium gas more than specified in Table 1-1.

2. Adding helium gas and charging equipment

When charging helium gas or performing helium line decontamination, refer to the “Maintenance” section and follow the instruction.

The equipment (regulators, charging hoses, adapters, etc.) that can be used at the pressure of 2.0MPaG or higher are required to perform the above work.

3. Do not startup/shutdown frequently

Do not startup/shutdown the compressor unit frequently.

The number of shutdown and startup of a compressor motor must be limited within 6 times per hour, and each status should be kept for at least 3 minutes. Frequent shutdowns and startups may shorten the insulation life of a compressor motor and may lead to failure. When the compressor unit runs multiple refrigerators, the number of shutdown and startup of refrigerator motors must also be limited within 6 times per hour.

Do not attempt to control the temperature of a Super Trap by starting up and shutting down the compressor unit.

Please contact us when the Super Trap needs temperature control operation.

4. Disposal of used adsorber



Ensure to discharge helium gas and remove either side of the self-sealing couplings from the used adsorber before disposing of it.

When the refrigerator system is not in operation, the helium gas pressure inside the adsorber is as high as the fill pressure of the compressor. Disposing the adsorber with helium gas inside may cause accidents. For example, if the adsorber was thrown in a burner reactor without discharging helium gas by mistake, the inside pressure of the adsorber would rise as the inside temperature rises and it may explode. If the adsorber was pressed with helium gas still inside, it may also cause an explosion. Refer to “Disposal Consideration” for more information.

Use appropriate charging adaptor to remove helium gas safely.

5. Electrical wiring connections



- Power supply voltage must be kept within the allowable range(refer to “Section 1 Table1-1 Compressor Unit Standard Specifications” . Applying more than the allowed voltage may damage the equipment.
- Install a ground-fault circuit interrupter(rated current: 30A, rated tripping leakage current:30mA 3 ϕ , rated voltage: 200V).
- Grounding conductor (earth wire) must be connected (D class grounding (with the ground resistance of 100 Ω)).
- Connect the refrigerator cable and remote cables (signal lines) to the compressor before connecting the compressor to the power supply. These wiring connections must not be done when the compressor is powered on. It could lead to a serious accident such as electric shock and/or damage to the equipment.
- Follow recommended sizes for wires and cables.
- Power lines and signal lines must be wired at least 10cm separate from one another.

6. Cooling water

Water leak may invite electric shock. Ensure there is no water leak from the cooling water piping. If the water pressure is too high, a leak may occur in the cooling water line inside the compressor unit. Adjust and control the cooling water supply pressure to maintain an allowable upper limit indicated in “Section 3 Figure 3-2 Cooling Water Requirement”

If water stain or some products accumulate in the water line inside the heat exchanger, heat exchange effectiveness will be significantly reduced and helium gas temperature will rise, this may shut down the compressor unit.

We employ the cooling water quality management standard of the Japan Refrigeration and Air Conditioning Industry Association as a standard value of water quality for compressor units. Please refer to “Section 3 Table 3-1 Recommended Cooling Water for Compressor”.

7. Ambient conditions of the compressor

The upper limit of the compressor operating ambient temperature is 38°C. Do not use the compressor in inappropriate conditions such as dusty, highly humid environments and/or places that are affected by strong electromagnetic waves. Keep electric terminals free from dust to avoid electrical leakage and/or a short circuit.

8. Maintenance precautions



1. Installation and maintenance of the product must be done by personnel in charge of the equipment or servicing who are familiar with the product structure and risk associated with the operation of the compressor.
2. Input power supply must be shut off before opening the cover of the compressor to avoid the risk of electrical shock.

Also, parts of inside the compressor unit are still hot just after the compressor has been stopped. Wait at least 15 minutes to open the cover to avoid the risk of burns.

9. Contact us immediately when the self-sealing coupling is loosened.



When working with a self-sealing coupling, the connection may be accidentally loosened or loosened by co-rotation. In such cases, the refrigerator may encounter faults due to helium leakage or air invasion, resulting in serious failure such as abnormal noise or refrigerator motor malfunction.

At the time of shipment of our products, we conduct the inspection to ensure the connection of self-sealing coupling is appropriate and paste a sealing sticker. The sealing stickers are added to our refrigerators, compressor units, flexible hoses, branch pipes and straight pipe units.

Contact us when the self-sealing coupling is loosened or removed by accident. Servicing for trouble is out of warranty if it occurs while the sealing sticker is not in the original state. The sealing sticker is located inside the panel of the compressor unit.

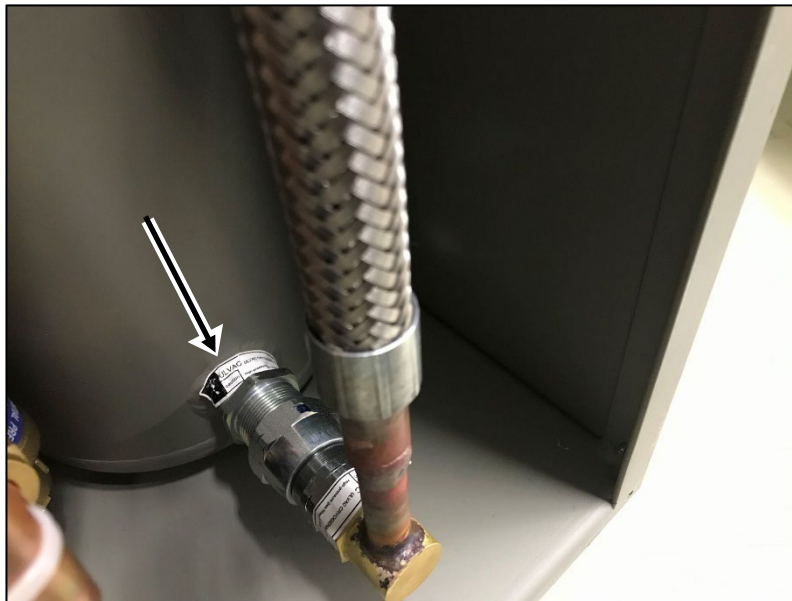







Figure Example of the sealing sticker pasted on the self-sealing coupling

Disposal Considerations

Disposal of our products must be done in accordance with applicable national and local laws and regulations.

				WARNING
<p>The cryopumps or cryocoolers may contain residue of hazardous substances resulting from actual use. Contact your safety supervisor and follow the instructions to remove such toxic substances before disposing</p>				

		WARNING
<p>Do not disassemble, pressurize, heat up a compressor unit, or throw it into fire. Such actions may lead to explosion of the adsorber inside the compressor unit. For safe disposal of an adsorber, follow the procedures below.</p> <ol style="list-style-type: none">(1) Remove high pressure helium gas inside the adsorber to reduce the internal pressure to the level of ambient atmospheric pressure. To do so safely, use tools appropriate to the adsorber coupling such as our charging adaptor (for cryocooler maintenance).(2) Remove the coupling to make it visible that the adsorber has been depressurized before proceeding to the next step.		

We provide Safety Data Sheet (called SDS) of our products upon your request.

Please contact us if necessary.

This page intentionally left blank.

1. COMPRESSOR DESCRIPTION

1.1	Introduction	1-1
1.2	Specifications	1-2

1.1 Introduction

The compressor unit compresses returned helium gas from the refrigerator unit (cold head) and feeds it back to the refrigerator unit as a high-pressure helium gas.

This compressor unit consists of:

1) a compressor, 2) a cooling system, 3) an oil separation system and 4) an adsorber.

An electric controller is installed to operate a compressor and a refrigerator.

In addition, a control box in which electric control devices required for operating the compressor unit and the refrigerator unit is attached.

The standard specifications of the compressor unit is described in Table 1-1, the external dimensions of the C30PZ is in Figure 1-1, parts names are in Figure 1-2, and functions of the parts in Table1-2.

The C30PZ does not have a feature of resuming operation after momentary power outage (*1).

In an event of a momentary power outage, the compressor unit shuts down the compressor motor, and sends a power source alarm (*2). To resume operation, release the alarm and send start-up signal.

The C30PZ does not meet SEMI-F47.

(*1) This refers to a feature that makes the compressor unit return to operation without sending start-up signal when a momentary power outage (on all phases) takes place.

(*2) Alarms related to power source are E-02 and E-10. Refer to the Table 4-3 in Section 4.

1.2 Specifications

Table 1-1 Compressor Unit Standard Specifications

Model: C30PZ		
Power Source	Volts x Phase x Hz	190 - 220VAC x 3 ϕ x 50Hz 200 - 230VAC x 3 ϕ x 60Hz
	Power (50Hz/60Hz) (*1)	6.5kW / 7.5kW \pm 5%
	Nominal Operating Current (50Hz/60Hz) (*1)	22A / 24A \pm 5%
	Rush Current (at AC200x3 ϕ x60Hz) (*2)	78A approximate (70 ms after starts up)
Cooling Type		Water cooled
Cooling Water Requirement (See Fig.3-2)		Temperature : 5 - 32°C Flow Rate : 5 - 15L/min Pressure Drop: 0.02 - 0.17MPa
Ambient Temperature		10 - 38°C
Compressor Winding Resistance		0.62 Ω (20 °C)
Adsorber Service Schedule		24000 h
Weight		161 kg

(*1) At starting up, the value increases by approx. 10%.

(*2) Incoming power condition:AC200Vx ϕ 3x60Hz.

◆ Helium Gas Pressure: (Room temperature : 20°C)

Charge Pressure (*1)	1.2 ± 0.04 MPaG
Operation Pressure <u>After Cooldown</u> On SUPPLY side (*2)	1.8 - 2.0 MPaG

(*1) The length of flexible hose: 15m

(*2) The Helium gas pressure may vary depending on the number of Super Trap, the temperature control and the length of flexible hoses, and it might slightly differ from the value above.

Ensure that the pressure will not exceed 2.1MPaG on the high pressure side immediately after starting operation.

◆ Compatible Super Trap/Cryopump and Compressor;

CRYO-T8SN-RM(RMS10LG) x 6(*) + CRYO-T6E-RM(RMS10LG) x 2(*)

or

CRYO-T8SN-RM(RMS10LG) x 6(*) + CRYO-U8HLH-RM(RM10) x 1(*)

(*): The figures show the maximum number of units that can be connected to a single C30PZ compressor unit.

◆ Connector Specifications

	CONNECTOR	MANUFACTURER	TYPE/MODEL	
1	INPUT POWER (4 documents)	JAE	Unit Side	MS3102A22-22P
			Cable Side	MS3106B22-22S Clamp : MS3057-12A
2	REFRIGERATOR (COLD HEAD) POWER (4 pins)	NANABOSHI	Unit Side	NJC-204-RF
			Cable Side	NJC-204-PM
3	REMOTE/RESPONSE Connector	DDK	Unit Side	57F-40500-20S
			Cable Side	57F-30500
4	FAILURE OUT Connector	DDK	Unit Side	57F-40140-20S
			Cable Side	57F-30140
5	RS232C Connector	DDK	Unit Side	17JE-13090-D2(D3A)A
			Cable Side	17JE-23090-02(D8A)-CG

※All connectors meet the UL standard.

※ No.1, 2: Cables will be attached. Please specify the length of the cables at time of order.

※ No.3~5: Cables are not attached.

- ◆ Cooling Water In/Out : Rc3/8 Female
- ◆ Helium Gas Supply/Return Coupling : 1/2B Self-Sealing Coupling
- ◆ Super Trap Temperature Control

Temperature Control	Refrigerator (cold head) ON/OFF type
Ultimate Cooling-down Temperature Setting	Default value : 123K Setting range : 45~350K (every 1K) Setting method : Input from the control panel. (*1)
Temperature Display (unit : K)	Display range : 45~400K (*2) Display location : TEMP display on the control panel.
Temperature Sensor	K (CA) thermocouple

(*1) The temperature can be set individually for each refrigerator.

Refer to section 4 for the setting method.

(*2) When 「HHHH」 or 「----」 is displayed, see Table 1-2 for details.

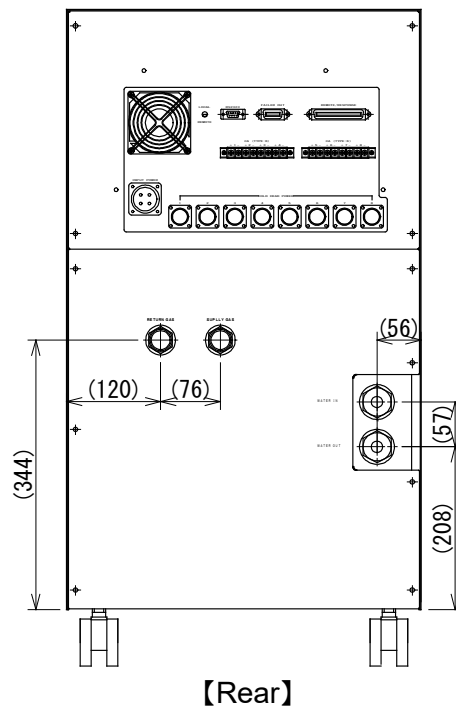
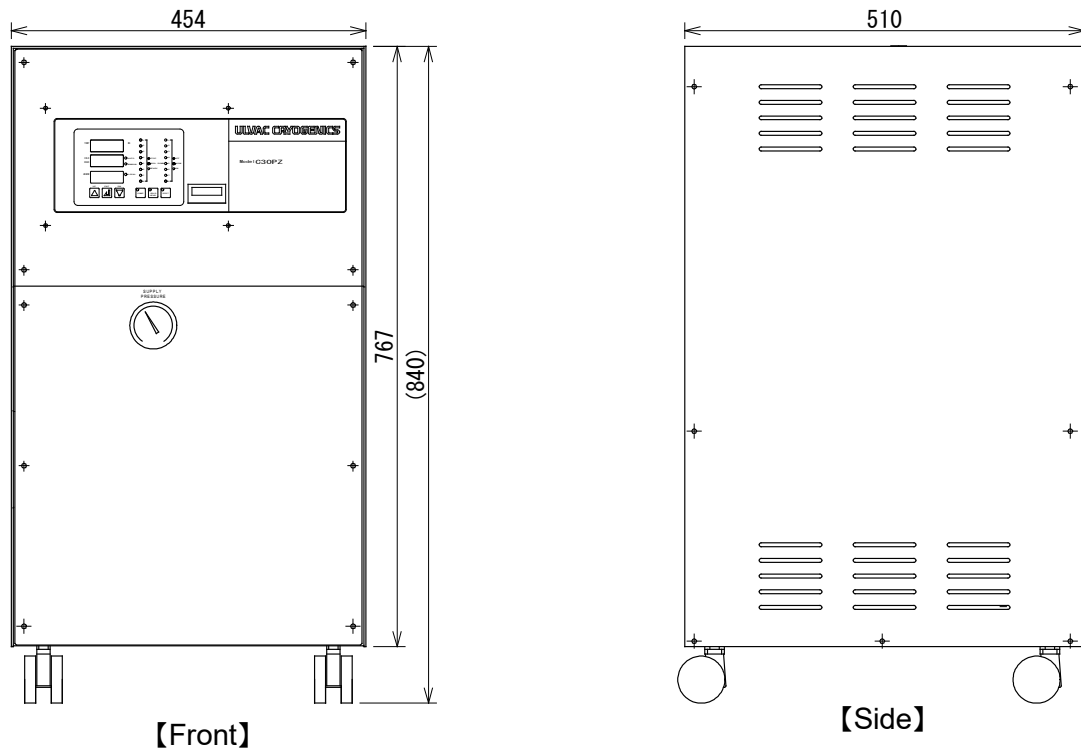

Figure 1-1 Dimensions

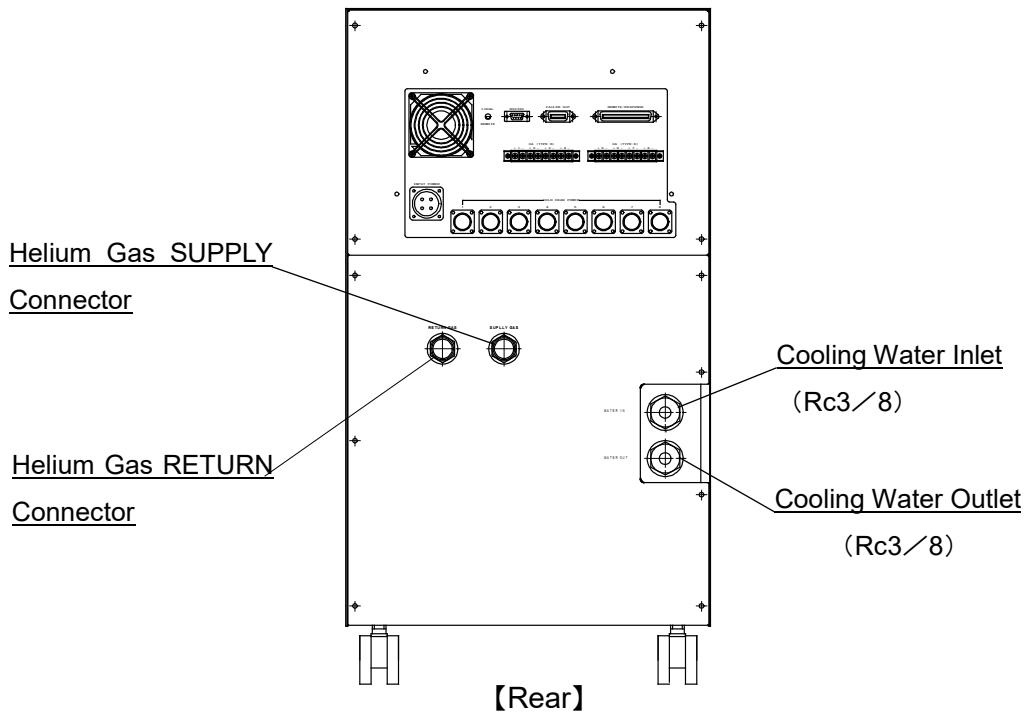
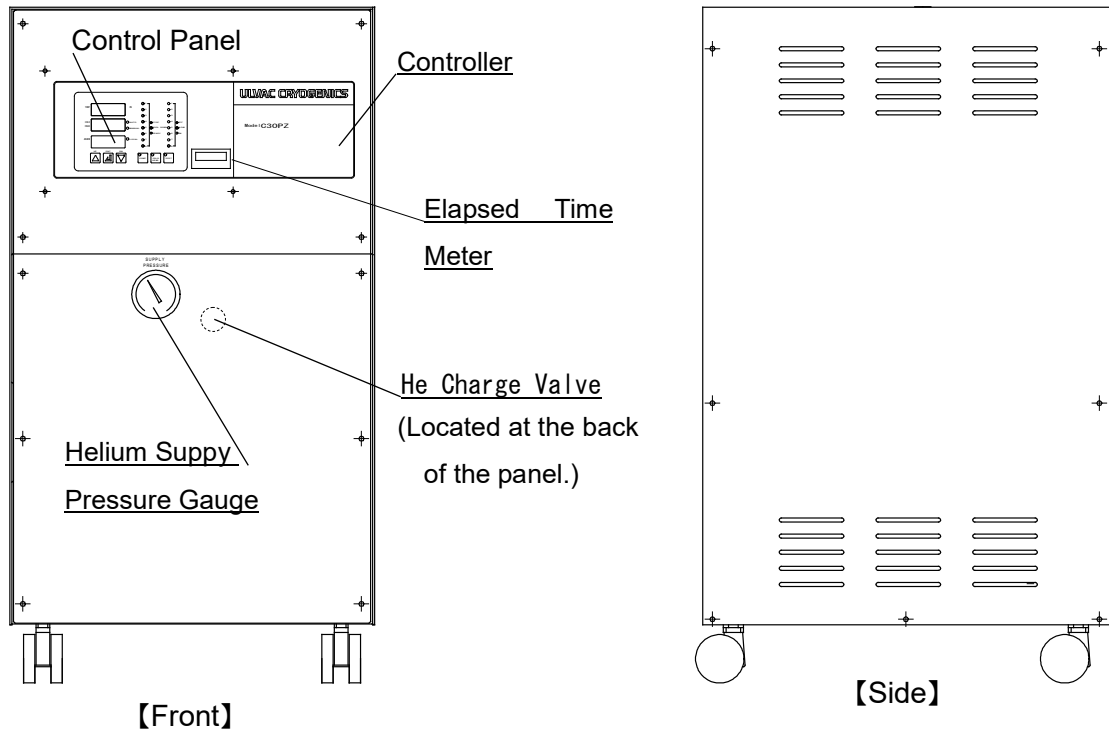

Figure 1-2 Components and Locations (1/3)

【Control Panel】

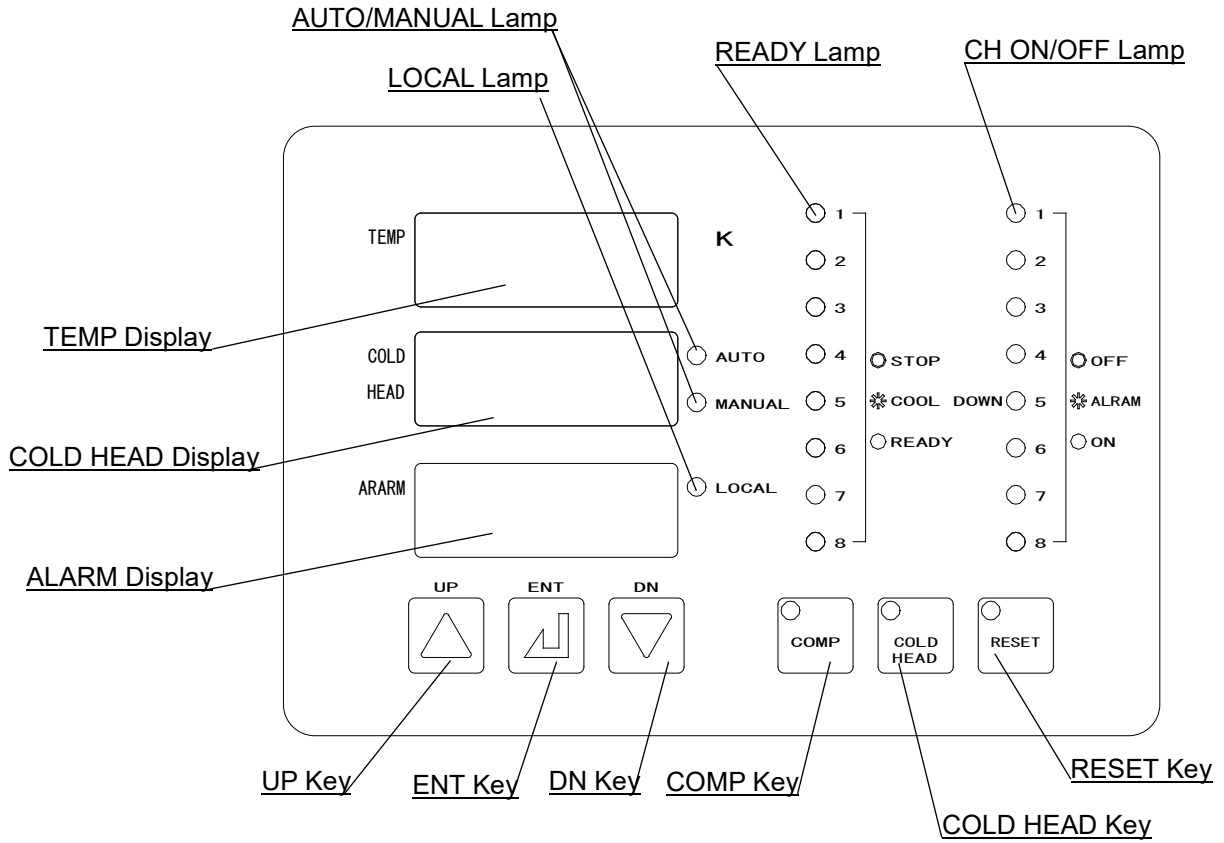
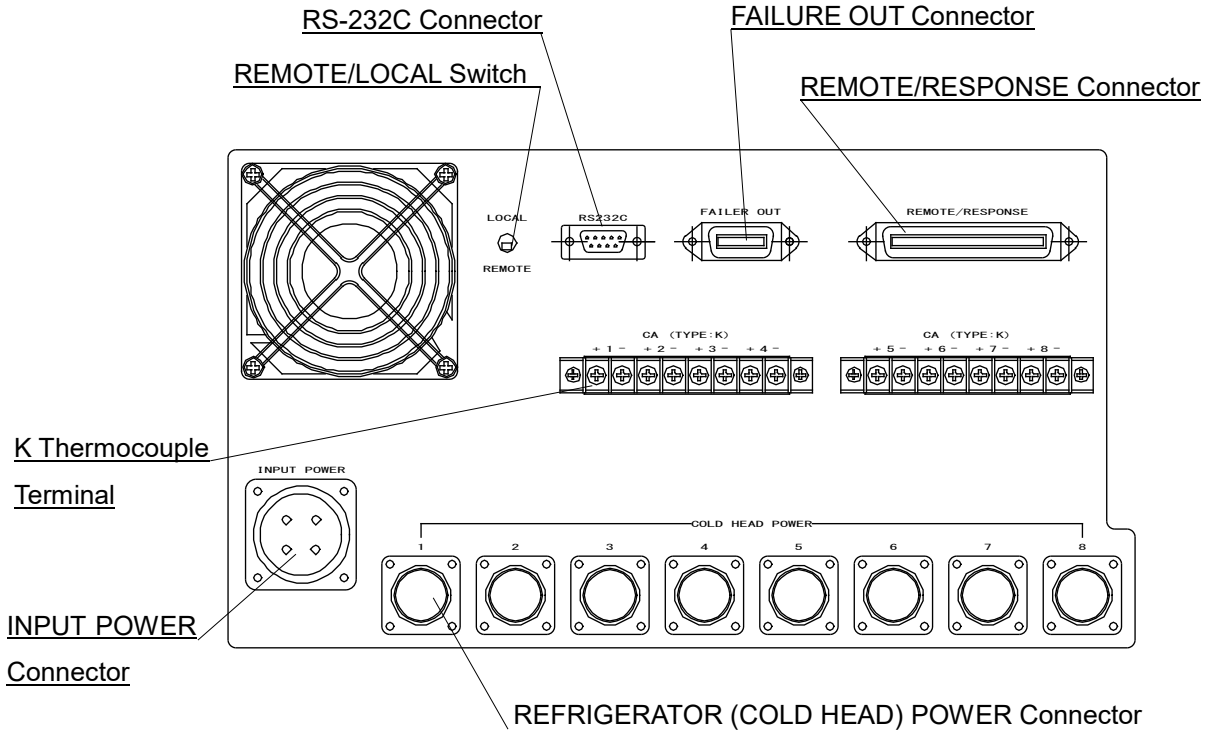

Figure 1-3 Components and Locations (2/3)

【Backside of Controller】



【Side of Controller】

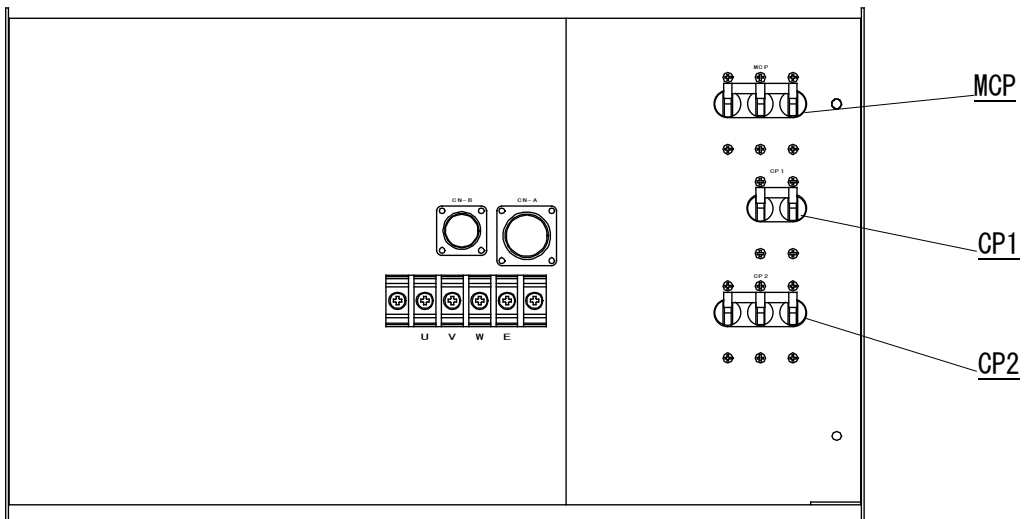

Figure 1-4 Components and Locations (3/3)

Table 1-2 Components Descriptions

Item	Description
TEMP Display	It displays the temperature of the selected refrigerator (cold head) that COLD HEAD Display indicates as CH number. Display range : 45~400K Display contents : 45 (flash) (less than 40K) 45 (40~45K) Normal display (45~400K) 400 (400~405K) HHHH (405~500K) HHHH (flash) (over 500K or failure) - - - - (parameter is OFF)
COLD HEAD Display	It indicates the selected refrigerator (cold head) number (CH1~CH8). 【How to switch the CH number】 Automatic: It changes every four seconds automatically. Manual: Press UP or DN key.
ALARM Display	It indicates alarm code when the alarm activates. (*1)
AUTO/MANUAL Lamp	When AUTO lamp lights on, COLD HEAD Display indicates different CH number automatically every four seconds. When MANUAL lamp lights on, you can change the indicated CH number by pressing UP or DN key. 【How to switch AUTO/MANUAL】 Press UP or DN key until AUTO or MANUAL lamp lights on.
LOCAL Lamp	LOCAL lamp lights on when REMOTE/LOCAL switch is in the LOCAL position.
READY Lamp	It indicates operational status of each super trap or cryopump. Display contents : Light off (Not operating) Flashing (Cooling down) Light on (READY for pumping (cool down completed))
CH ON/OFF Lamp	It indicates parameter setting of each super trap or cryopump. Display contents : Light off (Parameter is OFF) Flashing (ALARM activated) Light on (Parameter is ON)

(*1) Refer to Table 4-2, 4-4 for descriptions of ALARM code.

Table 1-2 Components Descriptions (Continued)

Item	Description
UP Key (*1)	It switches CH number indicated on the COLD HEAD display and a parameter in parameter setting mode.
ENT Key (*1)	It switches the display to parameter setting mode by long press and sets the parameter in parameter setting mode.
DN Key	It switches CH number indicated on the COLD HEAD display and a parameter in parameter setting mode.
COMP Key	When operating in LOCAL mode, it turns ON/OFF the compressor. *If turns it on within 5 seconds after turns it off, it takes 5 seconds to starts up again. The lamp will flash until the compressor starts up.
COLD HEAD Key	<ul style="list-style-type: none"> • When operating in MANUAL mode It turns ON/OFF the super trap or the cryopump displayed on COLD HEAD display. (A CH number of the super trap/cryopump will be displayed.) <ul style="list-style-type: none"> • When operating in AUTO mode It turns ON/OFF all the super traps or the cryopumps that have "CH ON/OFF" lamps on. However, when multiple super traps or cryopumps are operating, OFF command prior to ON.
RESET Key	It clears and resets the alarm. * REMOTE/RESPONSE and RS-232C communication can not reset the alarm.
REMOTE/ RESPONSE Connector	It is a connector to: <ul style="list-style-type: none"> • input ON/OFF signal for C30PZ and each CH. • output ON ANS signal for C30PZ and ON ANS and READY signal for each CH. * Refer to Figure B-1 and B-2 for details.
FAILURE OUT Connector	It outputs the alarm signal when the alarm activates. * Refer to Figure B-3 for details.
RS-232C Communication Connector	It is a connector for control command and status read command by RS-232C communication. * Refer to Appendix B-3 RS-232C for details.

(*1) Hold down the UP key and press the ENT key for 5 seconds to display helium gas supply pressure (on TEMP display), return pressure (on COLD HEAD display) and current value of the compressor unit (on ALARM display). While displaying these values, normal display and the alarm code will be disappeared. To return to normal display, press any key on the

control panel.

Table 1-2 Components Descriptions (Continued)

Item	Description
REMOTE/LOCAL Switch (*1)	<p>1) Operating in REMOTE mode Operating Method : REMOTE/RESPONSE or RS-232C communication Starting Method : 1. Send "ON" command to the target CH. 2. After receiving "COMP ON" command, C30PZ and the target CH will start. * While C30PZ is operating, if the "ON" command is sent to a CH which is not running, the CH will start. How to Stop : C30PZ and all CHs will stop by "COMP OFF" command. * By sending "COMP ON" command once again, all the CHs that were operating before being halt by "COMP OFF" command will restart.</p> <p>2) Operating in LOCAL mode (The LOCAL lamp on the control panel lights on) Operating Method : Control Panel Starting Method : <u>When AUTO lamp lights on</u> 1. Press COMP key to start the C30PZ. 2. Press COLD HEAD key and the selected CH by its parameter will start. <u>When MANUAL lamp lights on</u> 1. Press COMP key to start the C30PZ. 2. Press COLD HEAD key and the only CH indicated on COLD HEAD display will start. * Select the CH number by pressing UP key or DN key. How to Stop : <u>When AUTO lamp lights on;</u> • Press COMP key to stop the C30PZ and all CHs. • Press COLD HEAD key to stop all CHs. <u>When MANUAL lamp lights on;</u> • Press COMP key to stop the C30PZ and all CHs. • Press COLD HEAD key and the only CH indicated on the COLD HEAD display will stop.</p>

(*1) RESPONSE signals and FAILURE OUT signals are output whether it is operating in REMOTE mode or LOCAL MODE.

Table 1-2 Components Descriptions (Continued)

Item	Description
K Thermocouple Terminal	It is a terminal block to which the mounted K thermocouples in each refrigerator (cold head) will be connected.
INPUT POWER Connector	It is a connector to input main power for C30PZ.
COLD HEAD Power Connector	It is a connector to supply power for each refrigerator (cold head).
MCP	It is a circuit protector which shuts off the main power when short circuit occurs. (Manual reset) Rated Current : 30A
CP1	It is a branch circuit protector which shuts off power of the branch circuit when short circuit occurs. (Manual reset) Rated Current : 1A
CP2	It shuts off all the refrigerator (cold head) circuits including refrigerator motors and refrigerator cables when short circuit occurs in the refrigerator . (Manual reset) Rated Current : 15A

2. INSPECTION

2.1	Shipping List	2-1
2.2	Compressor Unit.....	2-2
2.3	Connecting Piping (Flexible Hoses)	2-2
2.4	Cables.....	2-2

2.1 Shipping List

When a product(s) delivered, make sure that there is no damage or shortage of delivered items by checking the external view of the package and the shipping list attached.

Please read the enclosed cover letter for the details. Depending on your specification, the option part(s) in Table 2-2 is attached.

Table 2-1 Shipping List

Item	Quantity
Compressor Unit	1
This Instruction Manual	1
REMOTE/RESPONSE Connector	1
FAILURE OUT Connector	1
RS232C Connector	1

Table 2-2 Optional parts

Item	Quantity
Input Power Cable (3m or customized length)	1
Refrigerator power cable (15m or customized length)	8 ^(*1)
Flexible Hose (15m or customized length)	2 ^(*2)
Helium Manifold (with 4 branch pipes)	2 ^(*3)
Lipped Bowl Spanner (Flexible hoses installing tool)	2
Gasket for Helium Coupling (Spare)	4

(*1)The quantity of a refrigerator power cable is decided with the number of refrigerators. The required number is different depending on your specification.

(*2)The volume of flexible hoses may change according to the specifications.

(*3)Two sets of standard Helium manifold of with four branch pipes are shipped. The number of branch pipes and the number of the manifold change with your specification.

2.2 Compressor Unit

Check the static helium gas pressure with the pressure gauge on the front panel.

The normal pressure is 1.2 ± 0.04 MPaG at room temperature (20°C).

The pressure slightly varies depending on the room temperature. See Figure 3-4.

If the room temperature is $20 \pm 10^\circ\text{C}$ and the pressure is 1.16 MPaG or less, add helium gas as directed in the instruction manual, section 6.3. If the pressure doesn't reach the normal level after the procedure, please contact our Service Engineering Division or the nearest Customer Support Center.

2.3 Connecting Piping (Flexible Hoses)



CAUTION

- Do not forcibly bend the flexible hose less than the minimum radius (250mm) or in a way that may damage the hose.
- Do not twist the connection of the flexible hose.
- Handle the hose with care and read Appendix C before use.

Check the flexible hose to ensure that there is no twist or break.

Leave the dust cap or plug as it is fixed when the flexible hose is not connected to the compressor unit and the cryopump.

2.4 Cables

Check the cables to ensure that they are intact.

If you find any missing parts or damages of the product, please contact our Service Engineering Division or the nearest Customer Support Center.

3. INSTALLATION

3.1	Installation	3-1
3.2	Connecting Cooling Water Piping	3-1
3.3	Cooling Water.....	3-2
3.4	Connecting the Super Trap (Refrigerator Unit) to the Compressor Unit	3-5
3.5	Connecting Electrical Cables	3-7

3.1 Installation

- Place the compressor unit on a level floor within 5°.
- The compressor unit must be operated in proper room temperature (10°C~38°C).
- Leave the spaces as shown in Figure 3-1 to make the following maintenance processes easier.
 - Pressure gauge inspection.
 - Gas charge valve operation.
 - Adsorber replacement.

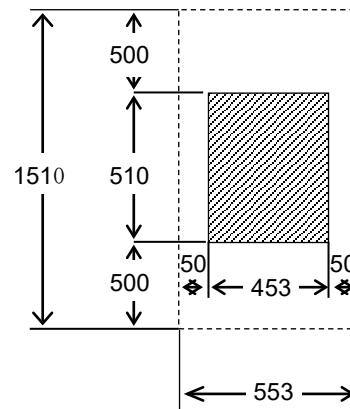

Figure 3-1 Maintenance Space (Unit: mm)

3.2 Connecting Cooling Water Piping

Install the cooling water piping as follows:

- Cooling water inlet/outlet connector : Rc3/8 female.
- Water pipes can be vinyl hoses or copper pipes as long as the withstanding pressure of those is 1.5 times higher than cooling water supply pressure.
- It is recommend that a filter is installed in the water line between the cooling water main valve and the compressor unit to prevent water scales. It is also recommended to install a flow meter (approx.0~15L/min.) between the filter and the compressor unit to check the flow rate.
- Ensure to connect inlet/outlet to the right place. Do not connect them the wrong way around.



CAUTION

Make sure that all water connections are tight.

3.3 Cooling Water

1. Determine the cooling water flow rate within the allowable range as shown in Fig. 3-2. Always use the proper cooling water that meets the requirement. Keep the cooling water supply pressure less than 0.7MPaG.



CAUTION

- If the temperature of cooling water is below 5°C, it can cause overloading or a difficulty in starting the compressor.
- If the temperature of cooling water is higher than 32°C, the thermal switch will be activated due to the overheat and turn off the compressor.
- Excessive flow rate shorten the lifetime of heat exchanger.

2. For the standard quality of cooling water, we refer to the water quality control standard set by The Japan Refrigeration and Air Conditioning Industry Association. See Table 3-1.



CAUTION

- Usage of poor quality water causes performance degradation of heat exchanger.
- Usage of water that doesn't meet the water quality control standard shortens the lifetime of the heat exchanger.

Table 3-1 Recommended Cooling Water for Compressor

Item	Unit	Allowable Range
pH (25°C) ^{※1}	pH	6.5 - 8.0
Conductivity (25°C) ^{※1}	mS/m	< 30
Chloride Ion, Cl ⁻ ^{※1}	mg / L	< 50
Sulfate Ion, SO ₄ ²⁻ ^{※1}	mg SO ₄ ²⁻ / L	< 50
Acid Consumption (pH4.8) ^{※1}	mgCaCO ₃ / L	< 50
Total Hardness ^{※1}	mgCaCO ₃ / L	< 50
Total Carbonic Acid ^{※1}	mg / L	< 10
Calcium Carbonate	mg / L	< 75
※1 The values of the items are based on the water quality management standards of Japan Refrigeration and Air Conditioning Industry Association.		

(*)The ground water may contain large amount of total carbonic acid and lower the pH value excessively. Therefore, if the ground water is used in the transient style, accidents may occur by corrosion even in a short-term use of the heat exchanger. Ensure that the density of carbonic acid is less 10mg/L. Since the dissolved ratio of total carbonic acid depends on the temperature and the pressure, analyze the ground water immediately after take it in without exposing to the atmosphere. Check the water supply whether it is the ground water or not before use. It is highly recommended to use cooling tower to circulate the water containing a large amount of carbonic acid.

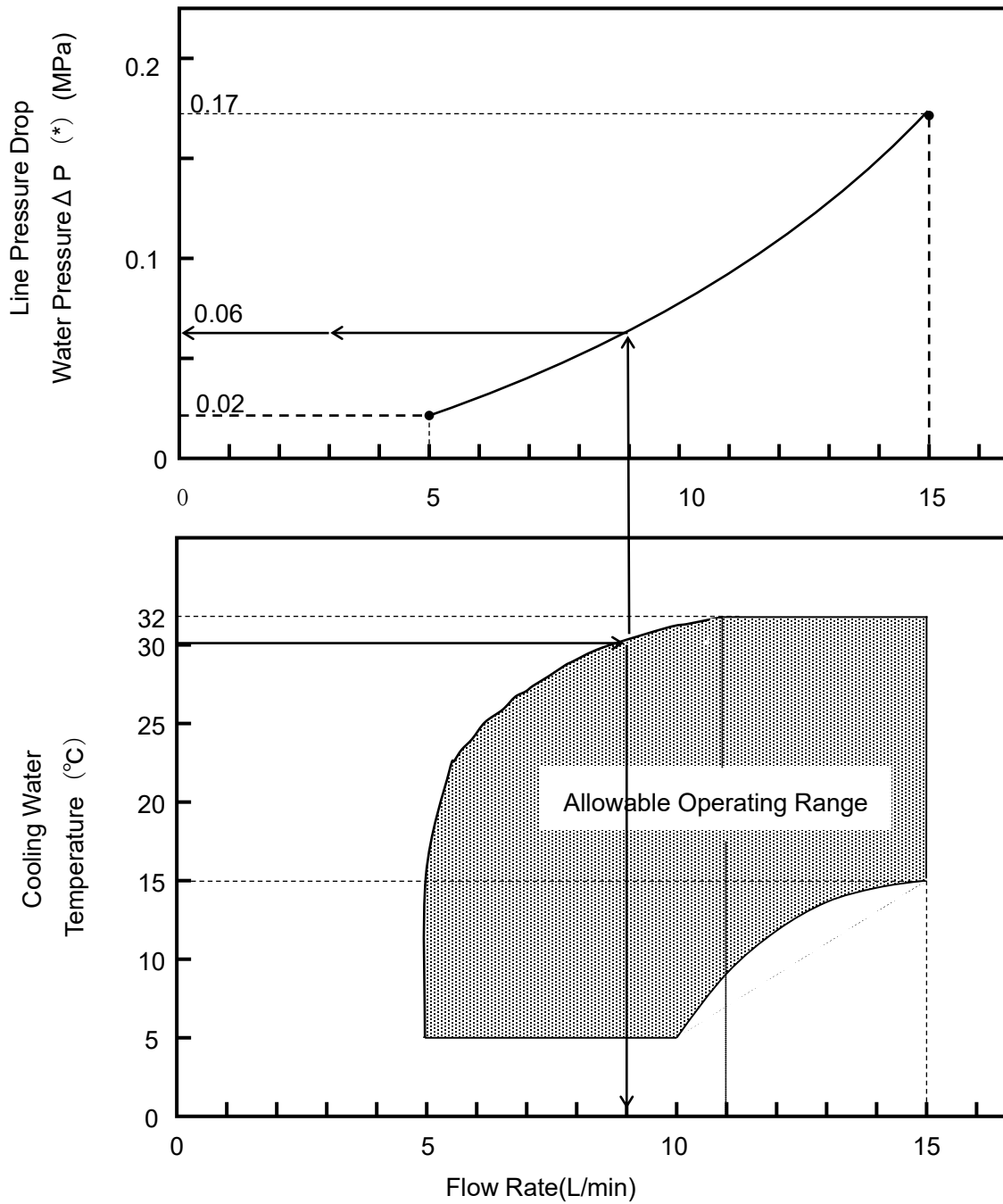

(*) The water pressure drop (ΔP) means differential pressure between cooling water supply pressure and return pressure.

EXAMPLE
 A dashed arrow (\rightarrow) in the graph shows the minimum required water flow rate (9L/min.) and water pressure drop (0.06MPa) at the water supply temperature of 30 °C.

Figure 3-2 Cooling Water Requirement

3. The cooling water should be stopped when the compressor is not running or it may damage the heat exchanger.

**CAUTION**

If the temperature of the cooling water is below 10°C, stop the cooling water when the compressor has been stopped. If the cooling water of temperature below 10°C is supplied continuously while stopping the compressor, it may increase viscosity of lubricant oil and cause start up failure of the compressor when the operation command is sent.

The cooling water must be drained and purged from the compressor unit when:

- There is a possibility that the cooling water might freeze when the compressor unit is not running. The water pipe can burst.
- The compressor unit will not be turned on for a long time (more than a week).
- Shipping the compressor unit.

Most of the cooling water can be purged from the compressor by blowing air into the compressor for 30 seconds at inlet pressure of 0.2MPaG with the outlet opened.

3.4 Connecting the Super Trap (Refrigerator Unit) to the Compressor Unit (Connecting Flexible Hose)



CAUTION

- Read the handling notes in appendix C about the connection of the flexible hoses.
- When connecting flexible hoses, always use two single open end spanners with width across flat 26mm and 30mm.
- Do not forcibly bend flexible hoses. They may be damaged and cause helium leakage.
- Do not connect or disconnect self-sealing coupling frequently. It may cause gas leakage. If there is a leakage, you may have to replace it with a new one according to the situation of the occurrence of leakage.

1. Remove all dust plugs and caps from supply and return flexible hoses, compressor unit and super trap (refrigerator unit). Clean flat rubber gaskets on the self-sealing couplings to be free from dust or metallic powder.
2. Connect the flexible hoses between the compressor unit and the super trap (refrigerator unit) as follows (see Figure 3-3):
 - a. Connect the helium-gas supply flexible hose to the helium-gas supply connector on the compressor unit. Connect the helium-gas return flexible hose to the helium-gas return connector on the compressor unit.
 - b. Connect the helium-gas supply flexible hose to the helium-gas supply connector on the super trap (refrigerator unit). Connect the helium-gas return flexible hose to the helium-gas return connector on the super trap (refrigerator unit).
3. Check the helium gas pressure on the compressor unit. The standard filling pressure is $1.2 \pm 0.04 \text{ MPaG}$ at 20°C . Refer to Figure 3-4. If the pressure is higher than the specified value, pull out the helium gas by opening the gas charge valve slowly. If the pressure is lower than the specified value, charge helium gas as described in Section 6.3 in this manual.



CAUTION

Do not operate the compressor unit when helium gas is overcharged (exceed 1.24 MPaG at 20°C room temperature).

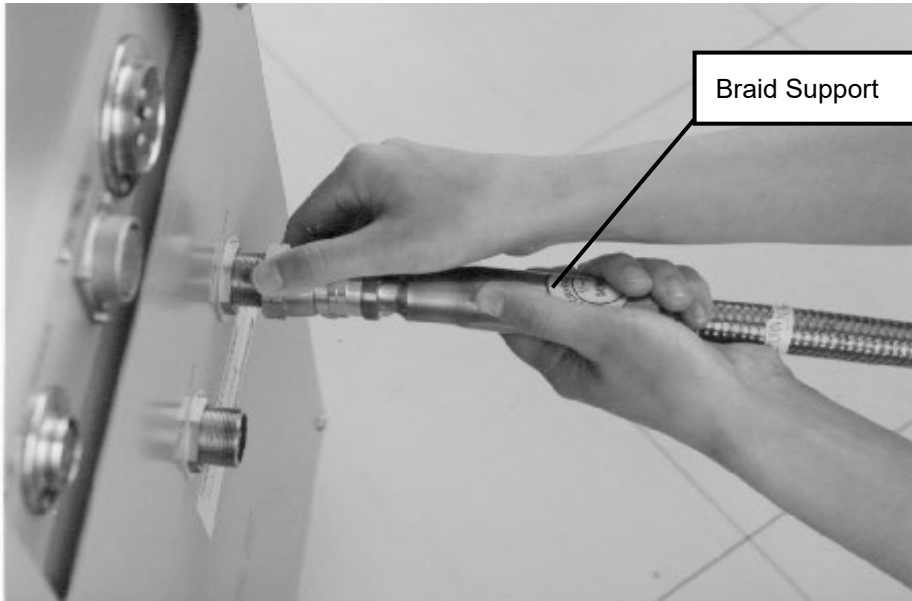

① Hold the braid support straight and tighten the self-sealing coupling by hand.

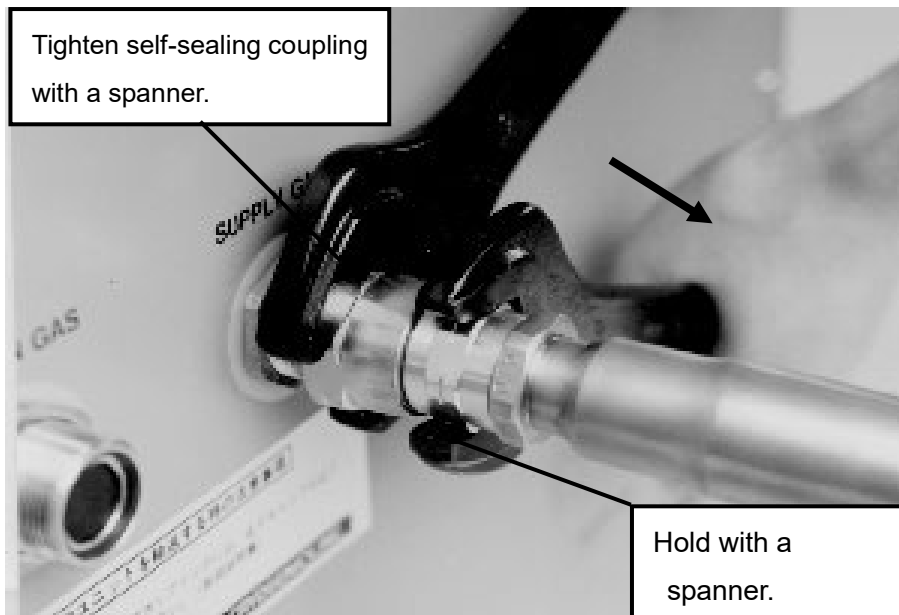

② Tighten the self-sealing coupling using two spanners until the fittings are firmly sealed. When using torque wrench, the recommended torque value is 20N·m.

Figure 3-3 Connecting Flexible Hose

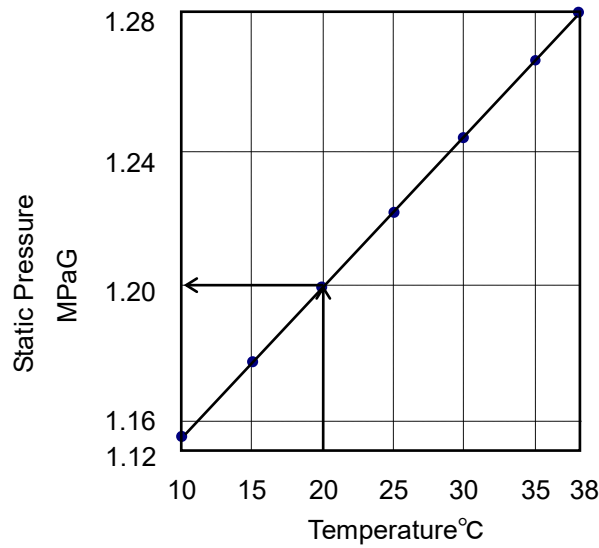

Figure 3-4 Static Pressure and Temperature

3.5 Connecting Electrical Cables

		WARNING
Do not connect the compressor to power supply until all wiring and connections are completed.		

1. Connecting the refrigerator cable
Connect the refrigerator input connector on the cryopump/super trap and refrigerator connector on the compressor unit with the refrigerator cable.
2. Connecting the K thermocouple
Connect each end of the K thermocouple to the K terminal on the compressor unit.
Connect the red wire of K thermocouple to the (+) terminal.
3. Connect the ground.
4. Remote wiring (Refer to Appendix B-1,2)
Wire the REMOTE/RESPONSE and FAILURE OUT.
Set the REMOTE/LOCAL switch on the front panel as REMOTE.
5. RS232C wiring.
Wire RS232C (Refer to Appendix B-4)

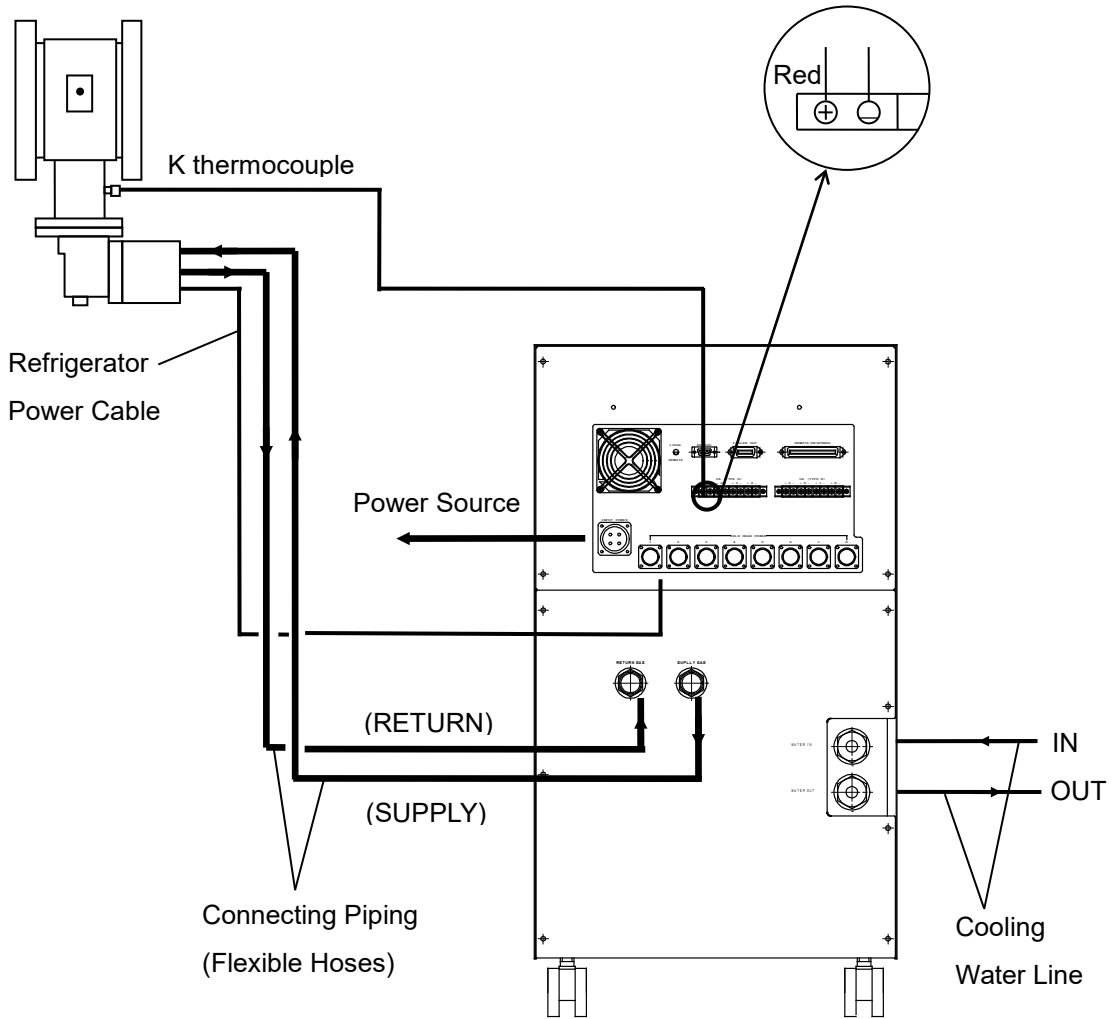

Figure 3-5 C30PZ Connections

4. OPERATION

4.1 Power-on Procedure	4-1
4.2 Parameter Settings.....	4-2
4.3 Pre- operation Check	4-5
4.4 Normal Operation	4-6
4.5 DIP[dual-in-line] Switch Settings	4-6

4.1 Power-on Procedure

Connect the compressor power cable to the power supply. Turn on the compressor and check that no ALARM code appears on the ALARM display. If it does, follow the instruction in Table 4-1.

Table 4-1 Alarm Codes at Power-on Procedure

Alarm Codes	Alarm Reset Method
EPEr	Alarm Reset Procedure 1. Press RESET key for more than three seconds. The warning beep will stop and the alarm display will flash "Init". 2. Press ENT key for more than six seconds. Then, the initialization will be completed. * Set the parameter if you need to change the default because the parameter will be initialized at this time.
cPu1	Return the compressor to ULVAC CRYOGENICS INC.
cPu2	Return the compressor to ULVAC CRYOGENICS INC.

4.2 Parameter Settings

Follow the instructions below to change the parameter settings. Refer to Figure4-1 and Table4-2 for details.

1. Press ENT key for more than one to move to the parameter settings screen. (TEMP display flashes at this time.)
 TEMP display : displays items
 COLD HEAD display: displays set value
2. Select the item with UP or DN key and press ENT key. (COLD HEAD display flashes at this time.)
3. Modify the set value with UP or DN key.
4. Press ENT key to set the value. (TEMP display flashes at this time.)
5. Press ENT key for more than one second to close the parameter setting screen.

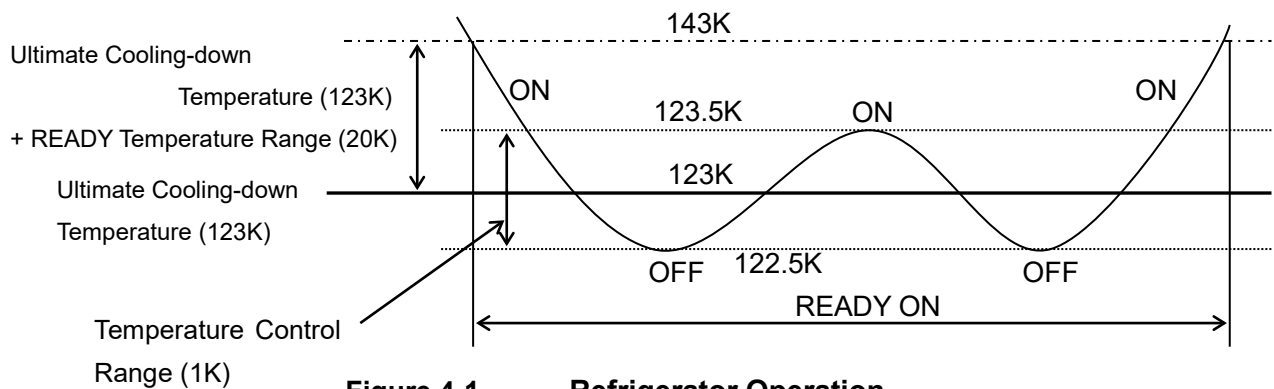

Figure 4-1 Refrigerator Operation

The temperatures in brackets are default values.

When the parameter No.1 is set to CP mode, CH7 is unavailable and CH8 is dedicated to the cryopump operation. (Temperature control operation showed in Figure4-1 is inapplicable).

Table 4-2 Parameters List

Number	Item	Display	Adjustable Range	Default	Remarks
1	Operation Mode Select	Unit_	tP/cP	(tP)	
2	CH1 Valid/Invalid	CH-1	ON/OFF	(ON)	
3	CH1 Ultimate Cooling-down Temp.	1.SP1	45-350	(123K)	
4	CH1 Temp. Control Range	1.SP2	1-30	(1K)	
5	CH1 READY Temp. Range	1.SP3	1-50	(20K)	
6	CH2 Valid/Invalid	CH-2	ON/OFF	(ON)	
7	CH2 Ultimate Cooling-down Temp.	2.SP1	45-350	(123K)	
8	CH2 Temp. Control Range	2.SP2	1-30	(1K)	
9	CH2 READY Temp. Range	2.SP3	1-50	(20K)	
10	CH3 Valid/Invalid	CH-2	ON/OFF	(ON)	
11	CH3 Ultimate Cooling-down Temp.	3.SP1	45-350	(123K)	
12	CH3 Temp. Control Range	3.SP2	1-30	(1K)	
13	CH3 READY Temp. Range	3.SP3	1-50	(20K)	
14	CH4 Valid/Invalid	CH-4	ON/OFF	(ON)	
15	CH4 Ultimate Cooling-down Temp.	4.SP1	45-350	(123K)	
16	CH4 Temp. Control Range	4.SP2	1-30	(1K)	
17	CH4 READY Temp. Range	4.SP3	1-50	(20K)	
18	CH5 Valid/Invalid	CH-5	ON/OFF	(ON)	
19	CH5 Ultimate Cooling-down Temp.	5.SP1	45-350	(123K)	
20	CH5 Temp. Control Range	5.SP2	1-30	(1K)	
21	CH5 READY Temp. Range	5.SP3	1-50	(20K)	
22	CH6 Valid/Invalid	CH-6	ON/OFF	(ON)	
23	CH6 Ultimate Cooling-down Temp.	6.SP1	45-350	(123K)	
24	CH6 Temp. Control Range	6.SP2	1-30	(1K)	
25	CH6 READY Temp. Range	6.SP3	1-50	(20K)	
26	CH7 Valid/Invalid	CH-7	ON/OFF	(ON)	*1
27	CH7 Ultimate Cooling-down Temp.	7.SP1	45-350	(123K)	*1
28	CH7 Temp. Control Range	7.SP2	1-30	(1K)	*1
29	CH7 READY Temp. Range	7.SP3	1-50	(20K)	*1
30	CH8 Valid/Invalid	CH-8	ON/OFF	(ON)	
31	CH8 Ultimate Cooling-down Temp.	8.SP1	45-350	(123K)	
32	CH8 Temp. Control Range	8.SP2	1-30	(1K)	*1
33	CH8 READY Temp. Range	8.SP3	1-50	(20K)	
34	RS232C Baud Rate	232C	300-9600	(9600bps)	
35	PRESS HIGH	PrEH	0-3.50	(2.4MPa)	*2
36	PRESS LOW	PrEL	0-3.50	(0.15MPa)	*2
37	CURRENT	Curr	0-50.0	(28.0A)	*2

*1 : If the operation mode (Parameter No.1) is set to CP, CH7 (Parameter No.26~29) and CH8 Temp. Control Range (Parameter No.32) are unavailable, and thereby not showed on the display.

*2 : Displayed only when DIP switch ② is ON.

Table 4-3 Alarm Codes List

ALARM display :E – * *

The codes are listed in order of priority. An alarm code will be indicated at once when the compressor is in operation. If the compressor is stopped, the code will be indicated when the operation signal is input.

Alarm Codes	Factor	Operation	Action
E-01	CP2 has tripped.	Stop	Contact us.
02	AC power wrong connection (reverse or loss of phase)	Stop	Check the power source.
03	Receiving emergency shutdown signal (unused)	Stop	Contact us.
04	TS1 turns OFF.	Stop	Contact us.
05	TS3 turns OFF.	Stop	Check cooling water.
06	LPS turns OFF.	Stop	Check helium static pressure.
07	CP3 has tripped.	Stop	Contact us.
08	MC fuse blow-out (on the COMP CTRL board)	Stop	Contact us.
09	TS2 turns OFF.	Stop	Contact us.
10	Answer from MC is incorrect.	Stop	Contact us.
91	Compressor motor current exceeds the setting.	Stop	Check parameter 37.
92	Gas supply pressure exceeds the setting.	Stop	Check parameter 35.
93	Gas return pressure reduced below the setting.	Stop	Check parameter 36.
11	CH Fuse blowout detection (COMPIFB) *1 *2	Stop only CH1	Contact us.
21		Stop only CH2	Contact us.
31		Stop only CH3	Contact us.
41		Stop only CH4	Contact us.
51		Stop only CH5	Contact us.
61		Stop only CH6	Contact us.
71		Stop only CH7	Contact us.
81		Stop only CH8	Contact us.

Alarm Codes	Factor	Operation	Action
12	When CH is operating, the answer from relay is incorrect. *2	Stop only CH1	Contact us.
22		Stop only CH2	Contact us.
32		Stop only CH3	Contact us.
42		Stop only CH4	Contact us.
52		Stop only CH5	Contact us.
62		Stop only CH6	Contact us.
72		Stop only CH7	Contact us.
82		Stop only CH8	Contact us.
13	K thermocouple disconnection *1 *2	Stop only CH1	Check K thermocouple.
23		Stop only CH2	Check K thermocouple.
33		Stop only CH3	Check K thermocouple.
43		Stop only CH4	Check K thermocouple.
53		Stop only CH5	Check K thermocouple.
63		Stop only CH6	Check K thermocouple.
73		Stop only CH7	Check K thermocouple.
83		Stop only CH8	Check K thermocouple.

*1 : Blowout of CH and K thermocouple will be displayed even when the compressor unit has been shut off.

*2 : When the CH is unavailable by parameter setting, blowout of the CH, answer from relay and disconnection of K thermocouple will not be detected.

4.3 Pre- operation Check

Before operating the compressor unit, check the following points.

- 1 . Appropriate setting of the ultimate cooling-down temperature.
- 2 . Power source voltage is within the specified range.
- 3 . TEMP and COLD HEAD displays are normal when turning on the compressor.
- 4 . REMOTE/LOCAL switch meets the requirements for use.
- 5 . All connections are tight.
- 6 . Using cooling water that meets the requirements.
- 7 . Helium gas static pressure is within allowable range.

4.4 Normal Operation

1. Turn on the compressor unit. (Press COMP key when to operate in LOCAL mode.)
2. Turn on the refrigerator. (Press COLD HEAD key when to operate in LOCAL mode.)



CAUTION

- Adjust the helium gas SUPPLY pressure not to exceed 2.1MPaG just after starting up.
- Check the helium gas pressure during normal operation (after cooling down). (Refer to Table 1-1.)
- When a flexible hose is over 15m, the helium gas pressure tends to be high. In this case, open the gas charge valve very slowly and let a slight amount of helium gas out until the helium pressure gauge reads allowable value.

* If the ALARM display indicates an alarm code during operations, refer to troubleshooting in appendix A.

4.5 DIP[dual-in-line] Switch Settings

Change of DIP switch settings is not necessarily for all users, however if it is needed the procedure must be done before turning on the compressor unit. The switch is located on the CPU BOARD inside the controller.

Table 4-4 DIP Switch Functions

Switch Number	Contents	Default	OFF Function	ON Function
1	The operation when LOCAL mode is OFF.	OFF	Stop operating	Keep operating
2	The setting of parameter No. 35, 36, 37.	OFF	Unmodifiable	Modifiable
3	REMOTE signal method	OFF	Pulse ($\geq 100\text{ms}$)	Level
4	Undefined (needless to set)	OFF	—	—
5	Undefined (needless to set)	OFF	—	—
6	Undefined (needless to set)	OFF	—	—
7	Communication timer	OFF	3 seconds	10 seconds
8	Communication LF character	OFF	Without line feed (LF) character	With line feed (LF) character

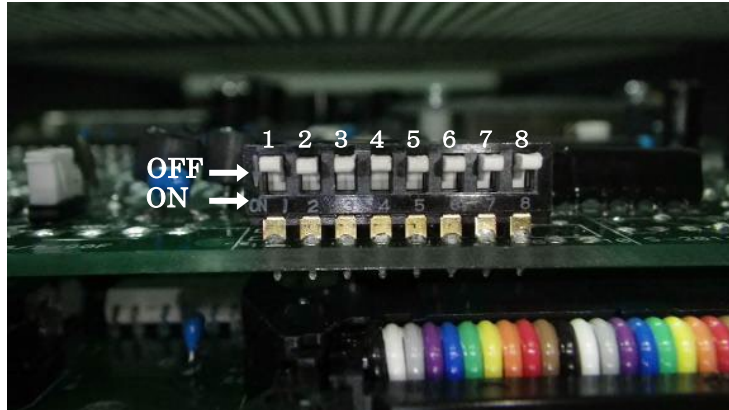

Figure 4-2 DIP Switch Default Position

This page intentionally left blank.

5. DISCONNECTION and STORAGE

5.1	Disconnecting Flexible Hose	5-1
5.2	Storage	5-2

5.1 Disconnecting Flexible Hose



CAUTION

When disconnecting flexible hoses, be sure to use two single open end spanners with width across flat 26mm and 30mm.

1. Shut down the compressor unit.
2. After the Super Trap and/or cryopump (refrigerator unit) has been warmed up to room temperature, disconnect the flexible hoses.



CAUTION

- If flexible hoses are disconnected while the cryocooler is still in low temperature, the pressure inside the cryocooler will rise as it warms up, resulting in helium leakage by activated pressure relief valve.
- Note that when performing helium circuit decontamination of the refrigerator unit, it is required to disconnect the flexible hoses at the compressor unit side immediately after shutdown.

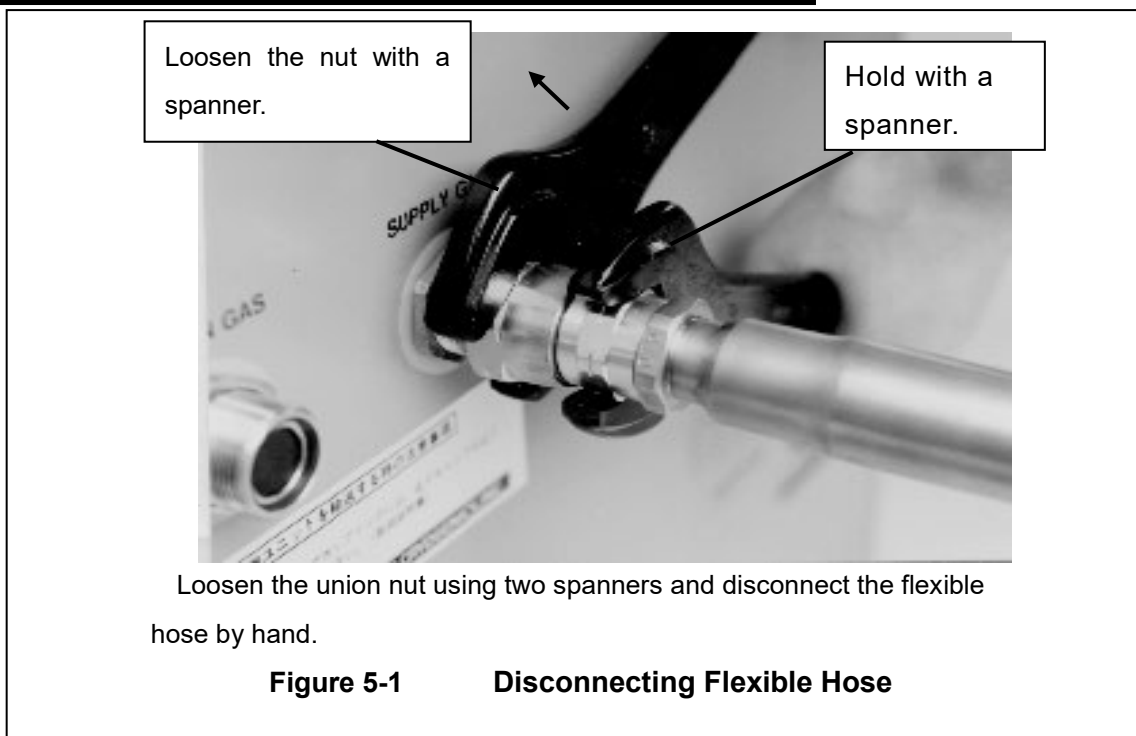

5.2 Storage

- ◆ Follow the instructions below to store the compressor unit.
 1. Disconnect the flexible hoses. Refer to Section 5.1.
 2. Disconnect cables and cooling water piping. Cooling water must be purged from the compressor unit. Refer to Section 3.3.
 3. Put the protective caps back on the helium gas connectors and cover the compressor unit with plastic sheet as they were shipped.
 4. Avoid direct sunlight, heat, humidity, vibration, radiation, dust, wind and rain.
 5. The compressor unit should be placed on level floor (within $\pm 5^\circ$) and fixed not to move and/or fall.
 6. Check the pressure gauge of the compressor unit periodically. Contact our Service Engineering Division or the nearest customer support center if the pressure keeps lower. There is a possibility that a leakage might have occurred.

- ◆ When the compressor unit is to be suspended for more than three months, follow the instructions below in addition to the above.
 - Operate the compressor unit for about an hour every three months to circulate lubricating oil to prevent the damage caused by the lack of the oil when starting the compressor unit again after long-term storage.

- ◆ When shipping the compressor unit, pack in the same way as at the time of shipment and avoid excess impact.

This page intentionally left blank.

6. MAINTENANCE

6.1 Scheduled and Unscheduled Maintenance.....	6-1
6.2 Replacement of Adsorber.....	6-1
6.3 Charging Helium Gas	6-3

	 WARNING
Always disconnect the compressor from all sources of electrical power before performing any maintenance procedures.	

6.1 Scheduled and Unscheduled Maintenance

◇Scheduled Maintenance : Replacement of the adsorber
(every 24000 hours (maximum))

◇Unscheduled Maintenance : Adding helium gas

6.2 Replacement of Adsorber

The interval between adsorber replacements **must not exceed 24000 operating hours**. Exceeding the specified time may result in malfunction and/or breakdown of the equipment.

◆Removing the Adsorber

1. Close the main valve of high vacuum system.
2. Shut down the refrigerator unit and the compressor unit.
3. Switch off the primary power.
4. Disconnect the flexible hoses from gas-return and gas-supply connectors at the rear of the compressor unit.
5. Remove the jam nuts holding the self-sealing coupling (male) on the rear panel.
6. Remove the rear panel from the compressor by unscrewing 7 screws.
7. Disconnect the flexible hose from the adsorber inlet.

**CAUTION**

When disconnecting and reconnecting the self-sealing coupling, always use two spanners as described in Section 3.4 and 5.1.

8. Remove the adsorber mounting bolt (M6).
9. Remove the adsorber from the compressor unit.

**WARNING**

Depressurize the adsorber before disposing of it.

Always use the charging adapter to depressurize the adsorber.

◆ Installing the Adsorber

1. Remove the dust caps from the self-sealing coupling halves at each end of the replacement adsorber.
2. Install the replacement adsorber by following the steps for adsorber removal in reverse order.
3. Connect the adsorber to the compressor internal piping.
4. Reinstall the rear panel.
5. Ensure that the helium pressure gauge reads 1.2 ± 0.04 MPaG. If the reading pressure is higher than allowable range, let out the gas very slowly by loosen the filling valve. If it is lower, add the gas by following the instructions in Section 6.3.
6. Write installation date and elapsed time on the adsorber label. Also write elapsed time for the next replacement of adsorber (plus 24000 hours to the present elapsed time).

6.3 Charging Helium Gas

Please supply the equipments for charging helium gas (regulators, charging hoses, adapters) that can be used at 2.0MPaG or above.



CAUTION

If the helium pressure gauge of the compressor unit shows 0 MPaG, contamination caused by air or moisture may occur in the system. If it occurs, contact our Service Engineering Division or customer support center.

When helium gas pressure is lowered, it is necessary to replenish the gas. Investigate the cause of the pressure reduction before adding helium gas. If there is a leakage, take an adequate measure before charging. Improperly connected self-sealing coupling might be one of the causes of the leakage.

- ◇It is recommended to use the regulator which shows the range of 4~6 MPaG as outlet pressure.
- ◇The gas charge inlet of the compressor unit is 1/4B male flare.
- ◇Use helium gas with purity of 99.999% or more.

The filling method of helium gas is as follows:

1. When mounting the regulator on a new helium bottle, perform the following procedures in order to purge the air and fill helium gas in the gas line between the regulator and the bottle valve.
 - a. Open the regulator a little. The regulator can be opened commonly by turning the handle clockwise.
 - b. Slowly open the bottle valve, and purge the air in the gas line for several seconds.
 - c. Close the regulator.



CAUTION

If the bottle valve is opened ignoring the above procedures (1), the air between the regulator and the bottle valve diffuses into the helium bottle and lowers the purity of helium gas.

2. Remove the front panel of the compressor unit.
3. Connect the helium charging hose as follows:
 - a. Connect the charging hose to the regulator.
 - b. Loosely connect the charging hose to the charge inlet on the compressor unit so that helium gas can be slightly blown out here.
 - c. Open the regulator until the outlet pressure reaches 0.1 to 0.2 MPaG. Allow helium

- gas to flow out from the charging hose for about half a minute. Meanwhile, open the charge valve slightly in order to drive out the air that exists between the charge valve and the charge inlet.
- d. Tighten the flair nut at the end of charging hose and close the charge valve. Helium gas charge in the line between the regulator and the charge valve on the compressor has been completed.
4. Adjust the outlet pressure of the regulator at 1.8 MPaG. Pressure relief valve has to be mounted as well as the regulator.
 5. Open the charge valve slowly and perform the following instruction according to the state of the compressor.
 - a. If the compressor unit is running under normal operating conditions, replenish it with the pure helium gas until it reaches the operation pressure described in the compressor instruction manual.
 - b. If the compressor unit is not running, replenish it with the pure helium gas until it reaches the static pressure described in the compressor instruction manual.

**CAUTION**

If helium gas has been charged more than the prescribed pressure of 1.9MPaG or more, the pressure relief valve on the refrigerator may be going to work. Therefore charge helium gas slowly so that the pressure relief valve should not operate. On the other hand, the pressure relief valve in the compressor unit is set at 2.85MPaG.

6. Close the charge valve after charging helium gas.
 7. Close the regulator and remove the charging hose from the charge inlet.
- The replenishment work of the gas for the compressor has been completed with this.

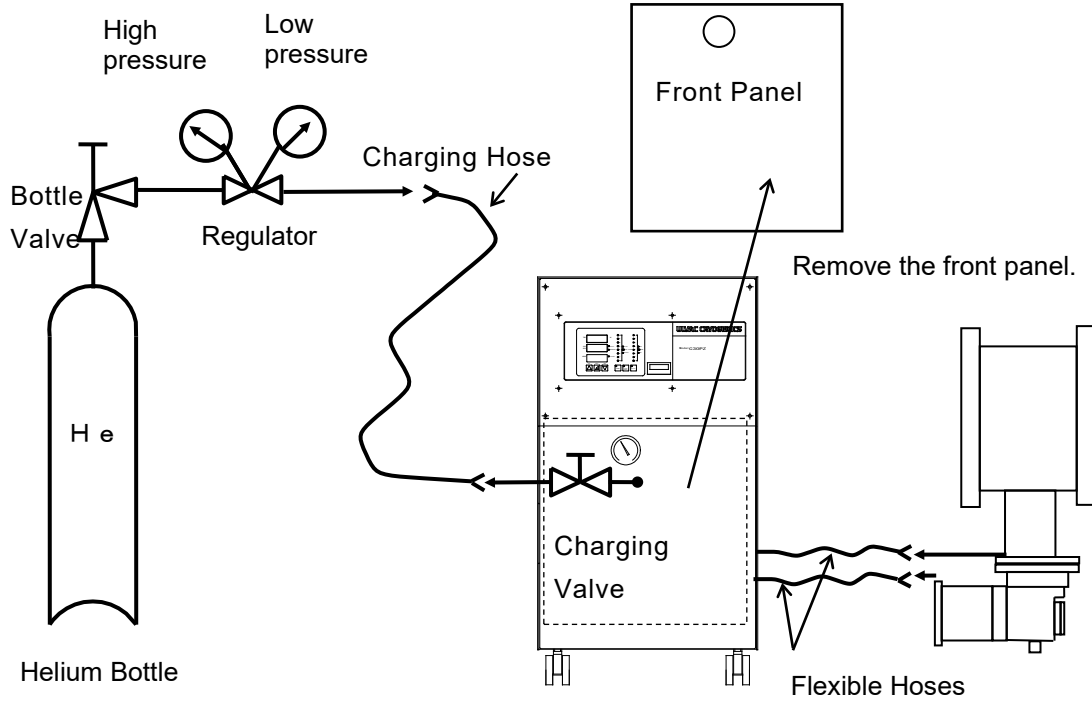

Figure 6-1 Charging Helium Gas

This page intentionally left blank.

Appendix A

TROUBLESHOOTING



			WARNING
<ul style="list-style-type: none"> ◆ Disconnect the compressor from its power source before performing any troubleshooting procedures. ◆ The compressor unit is hot after operating. Wait for the unit to cool down before working on the inside of the compressor. 			

Table A-1 Troubleshooting Fault Diagnosis

Problems	Possible Causes	Corrective Actions
I . When turning on the compressor, it will not start.	1) No power coming from source.	Check the power source connector associated with the power source.
	2) Circuit protectors (MCP, CP1, CP2) remain in OFF position.	Referring to Figure 1-2, turn on the circuit protector.
	3) The alarm has been activated. (Check the Alarm code on the ALARM display.)	Referring Table 4-2 and 4-4, correct the cause of the alarm. Then press RESET key.
II . Compressor unit stops during the normal operation.	The alarm has been activated. (Check the Alarm code on the ALARM display.)	Referring Table 4-2 and 4-4, correct the cause of alarm. Then press RESET key.
III . Compressor makes unusual noise during the normal operation.	The helium static pressure is high.	Do not charge helium gas over 1.24MPaG(at20°C).

Appendix B

CONTROL

1 . REMOTE/RESPONSE.....	B-2
2 . FAILURE OUT.....	B-5
3 . RS232C.....	B-9
3.1 Specifications.....	B-9
3.2 RS232C Connection Example.....	B-9
3.3 Communication Protocol.....	B-10
3.4 Message Formats.....	B-10
1 Control Commands.....	B-10
2 Status Read Commands.....	B-12
3 Error Codes.....	B-17
4 Communication Time-out.....	B-17

1. REMOTE/RESPONSE (for Customer's sequence signals)

When performing REMOTE operation, set the LOCAL/REMOTE switch on the rear panel in REMOTE position.

Table B-1 REMOTE/RESPONSE Description

REMOTE			RESPONSE		
Pin No.	Signal Type	Signal Form	Pin No.	Signal Type	Signal Form
1	COMP ON	PHOTO-COUPLER INPUT (*1)	14	COMP ON ANS	Tr OUTPUT (PHOTO-COUPLER) max.100mA
2	CH1 ON		39	CH1 ON ANS	
3	CH2 ON		15	CH2 ON ANS	
4	CH3 ON		40	CH3 ON ANS	
5	CH4 ON		16	CH4 ON ANS	
6	CH5 ON		41	CH5 ON ANS	
7	CH6 ON		17	CH6 ON ANS	
8	CH7 ON		45	CH7 ON ANS	
9	CH8 ON		21	CH8 ON ANS	
26	COMP OFF		42	READY No.1	
27	CH1 OFF		18	READY No.2	
28	CH2 OFF		43	READY No.3	
29	CH3 OFF		19	READY No.4	
30	CH4 OFF		44	READY No.5	
31	CH5 OFF		20	READY No.6	
32	CH6 OFF		46	READY No.7	
33	CH7 OFF		22	READY No.8	
34	CH8 OFF		25	COM(-24V)	
24	COM(+24V)		50	COM(-24V)	
48	COM(+24V)				
49	COM(+24V)				

(*1) When the DIP switch No.3 is ON (i.e. alternate mode), the C30PZ can be operated by COMP ON and CH1 ON ~ CH8 ON(Pin No.1 ~ 9) signals. In this case COMP OFF and CH1 OFF ~ CH8 OFF(Pin No.26 ~ 34)signals should not be used for the operation.

(1) REMOTE INPUT

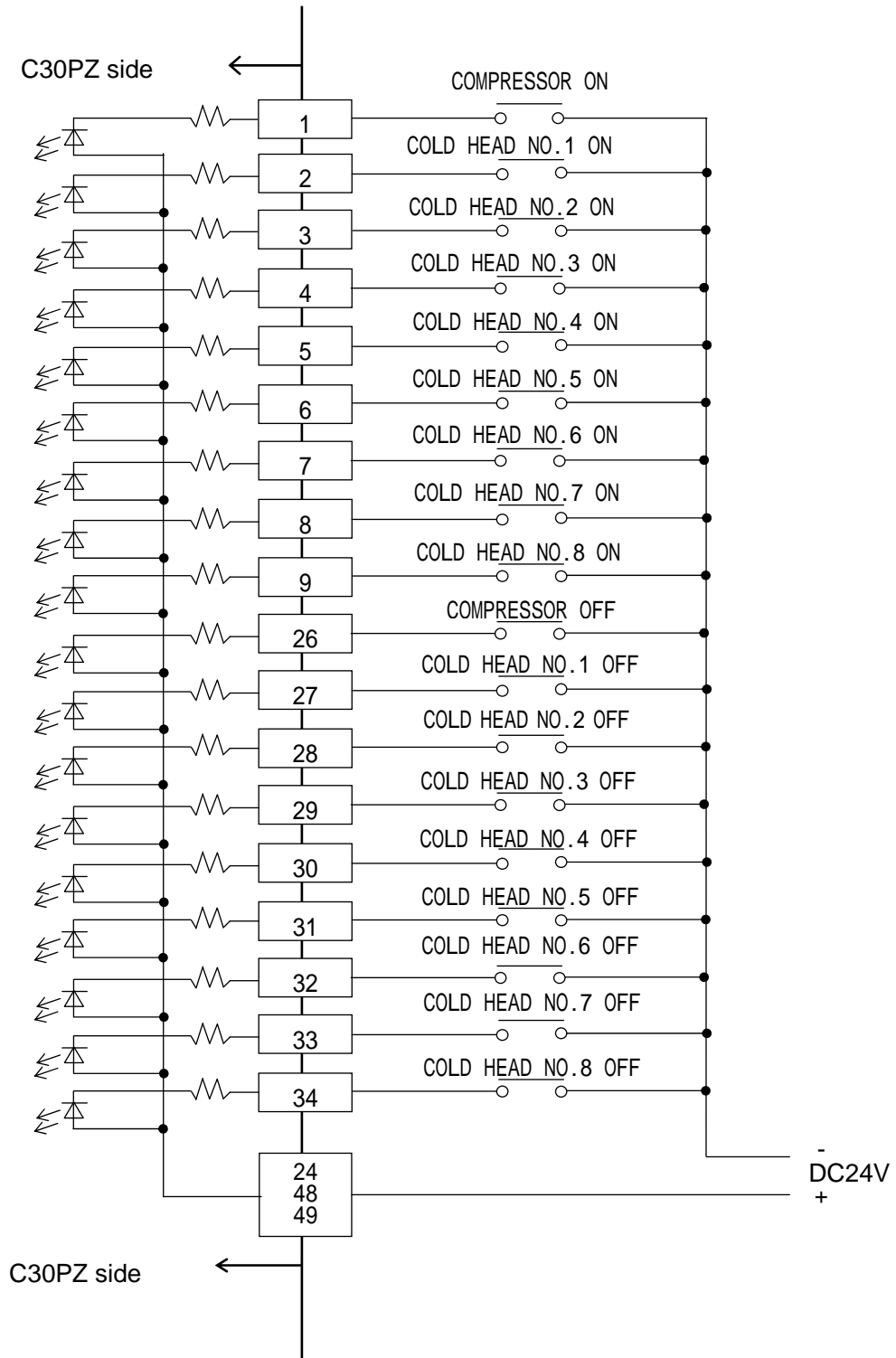

Figure B-1 REMOTE Wiring Diagram

(2) RESPONSE OUTPUT

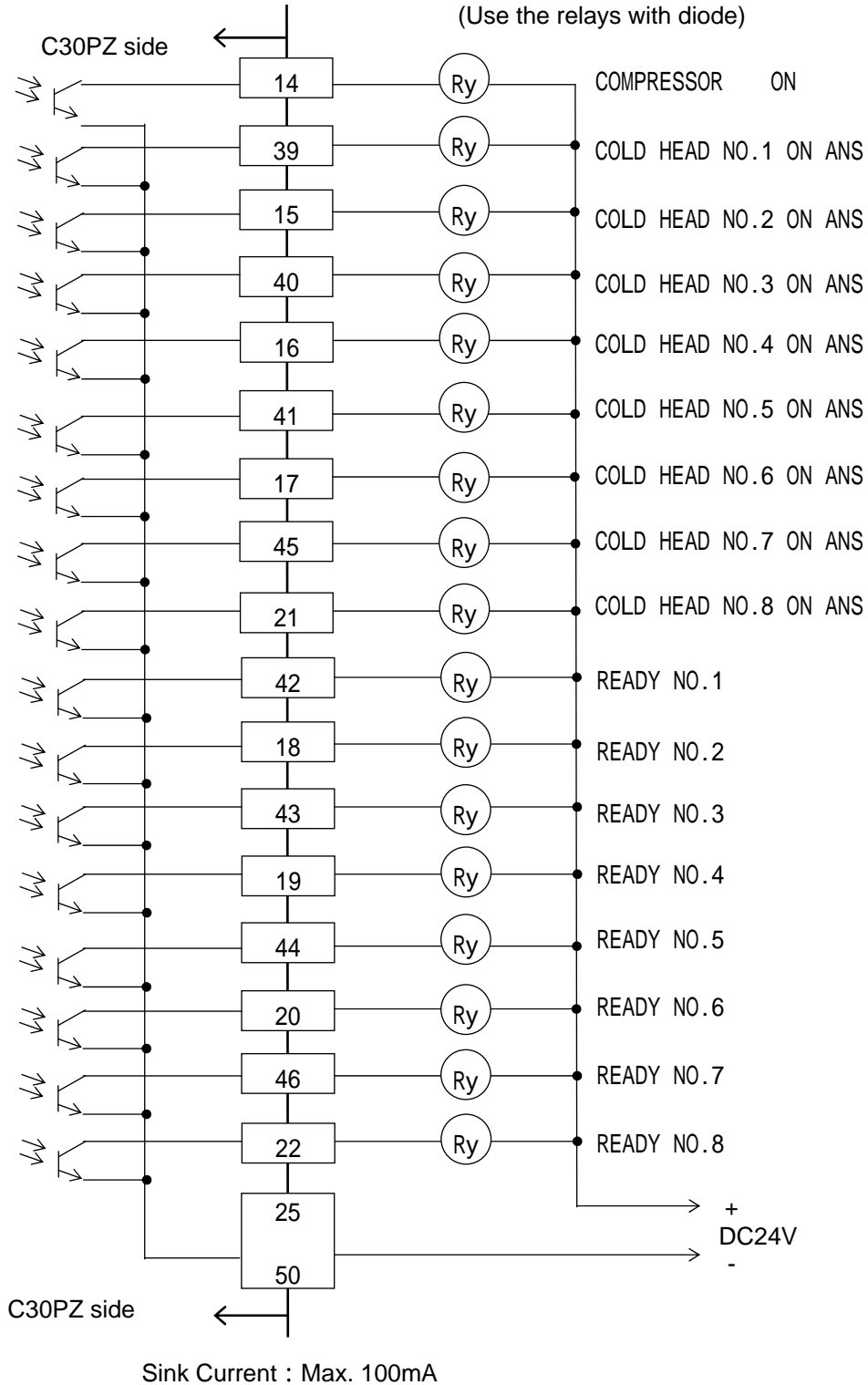

Figure B-2 RESPONSE Wiring Diagram

2 . FAILURE OUT (Emergency stop output signals)

Table B-2 Failure Out Description

FAILURE OUT			
ITEM No.	Signal Type	Output Requirements	Signal Form
1	FAILURE	When the alarm event described in Table 4-4 has occurred during operation.	Tr OUTPUT (PHOTO-COUPLER) max.100mA
2	WATER	Any one of following, TS1, TS2, TS3 is OFF.	
3	LOW PRESSURE	LPS is OFF.	
4	OVER LOAD	CP2 or CP3 is OFF, or the compressor motor current exceeds the setting value (parameter No.37).	
13	COM(-24V)		
14	COM(-24V)		

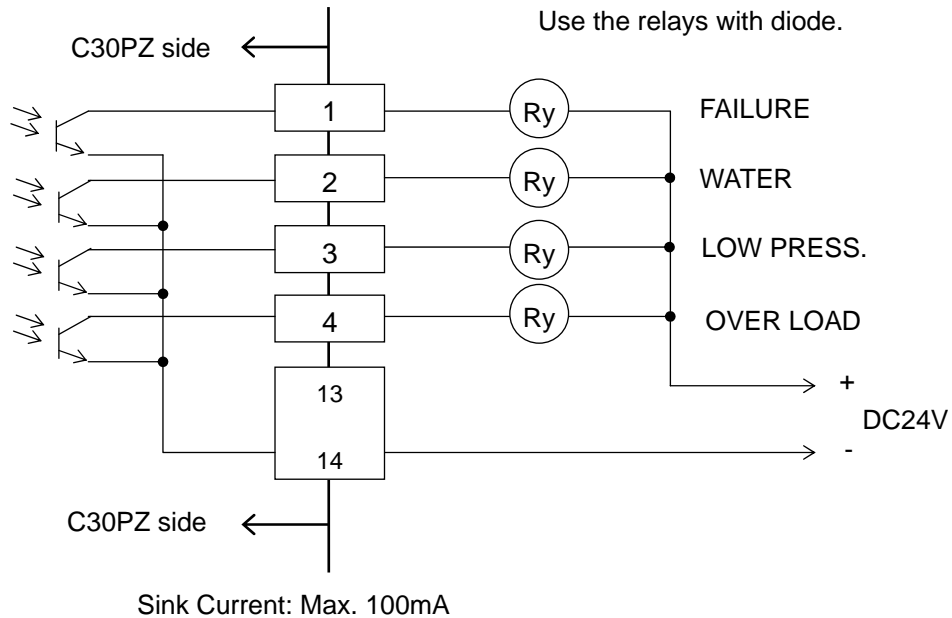
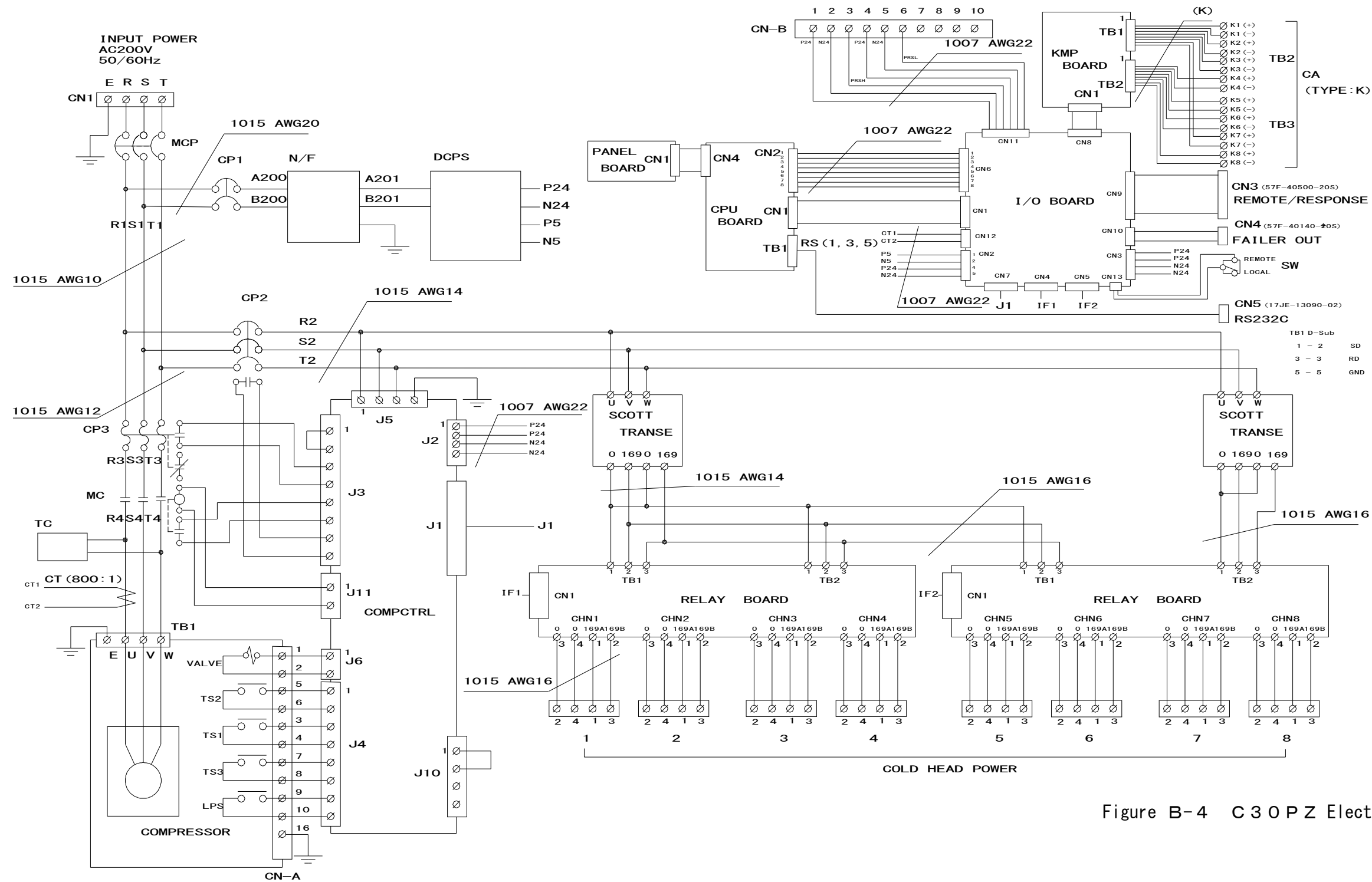

Figure B-3 FAILURE OUT Wiring Diagram

This page intentionally left blank.



3 . RS232C (D-sub 9pin connector)

3 . 1 Specifications

Transmit Type	Half-duplex
Communication Type	RS232C, 3 wires (SD, RD, SG)
Baud Rates (*1)	<u>9600</u> , 4800 , 2400 , 1200 , 600 , 300 [bps]
Data Bit	8 bit
Parity	--
Stop Bit	1 bit
Communication Control	--
Communication Error	In case of error, the command is invalid at the compressor side. (If no answer is coming, resend the command or perform time-out procedure from the HOST side.)

(*1) Factory setting: 9600[bps]

(*2) When the rear switch is in "LOCAL" position or the display shows parameter setting, the communication command will not be accepted.

3 . 2 RS232C Connection Example (Host side: 9 pin connector)

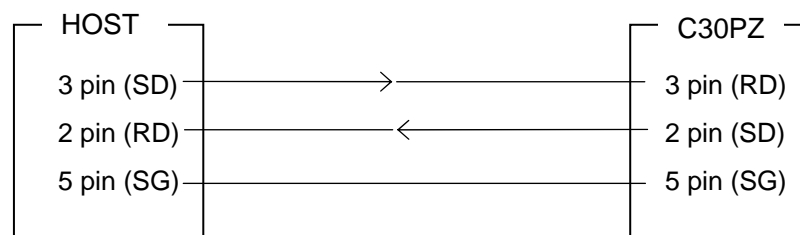

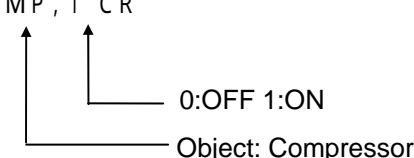
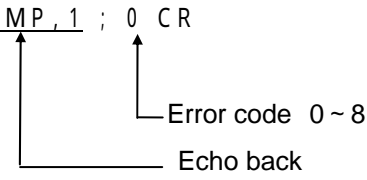
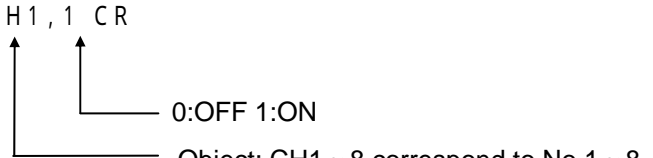
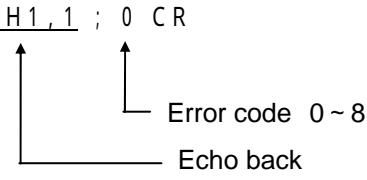
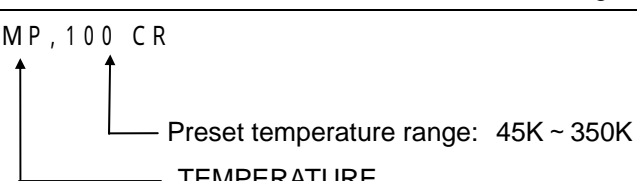
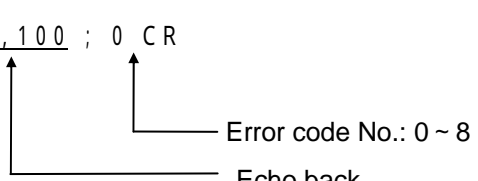
Compressor ON/OFF Command	
Command	: <u>CMP, 1</u> CR 
Response Example	: <u>CMP, 1</u> ; 0 CR 
COLD HEAD ON/OFF Command	
Command	: <u>CH1, 1</u> CR  <p>ex) CH1 is COLD HEAD No.1. In CP operation mode, CH8 is CP.</p>
Response Example	When COLD HEAD No.1 is turned ON, the following message will appear. : <u>CH1, 1</u> ; 0 CR 
Preset Temperature Command (CH1 ~ CH8 Collective Setting)	
Command	: <u>TMP, 100</u> CR 
Response Example	When the temperatures of cold heads are set to 100K, the following message will appear. : <u>TMP, 100</u> ; 0 CR 

Preset Temperature Command (Individual Setting)	
Command	<pre>: TMP 1 , 100 CR</pre> <p>Preset temperature range: 45K ~ 350K TEMPERATURE (TMP1 ~ 8 correspond to No. 1 ~ 8.) ex) TMP 1 is COLD HEAD No.1.</p>
Response Example	<p>When the COLD HEAD No.1 temperature is preset to 100K, the following message will appear.</p> <pre>: TMP 1 , 100 ; 0 CR</pre> <p>Error code No.: 0 ~ 8 Echo back</p>

2 Status Read Commands

- Start Character “:”= 3AH
- Delimiter “CR”= 0DH
- “,”= 27H
- “:”= 3AH
- “;”= 3BH

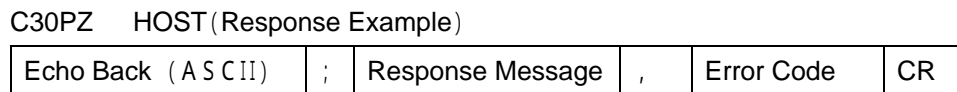
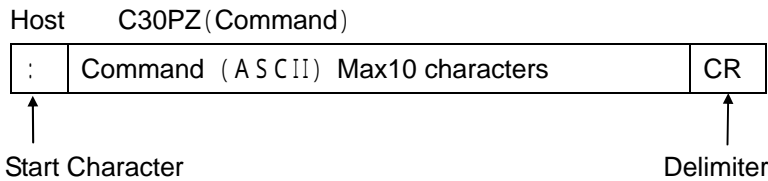

Statuses can be read even if the CHs are invalid by its parameter setting.
 When the C30PZ is in CP operation mode (CH:1 ~ 6, CP: 8), the status of CH7 can also be read. However, invalid CH(s) by the parameter settings and CH7 will not operate.

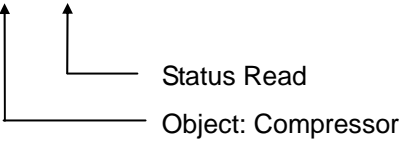
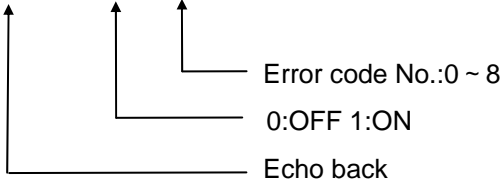
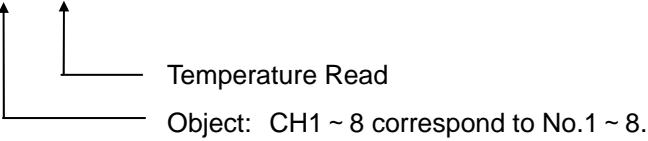
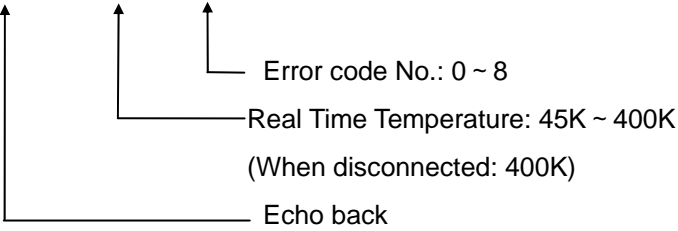
Compressor ON/OFF Status	
Command	: <u>CMP</u> , S CR 
Response Example	When the compressor unit is OFF, the following message will appear. : <u>CMP</u> , S ; 0 , 0 CR 
COLD HEAD (No.1 ~ 8) Temperature	
Command	: <u>CH1</u> , T CR  ex) CH1 is COLD HEAD No.1. When CP operation mode, CH8 is CP.
Response Example	When COLD HEAD No.1 temperature is set to 100K, the following message will appear. : <u>CH1</u> , T ; 100 , 0 CR 

COLD HEAD (No.1 ~ 8) ON/OFF Status	
Command	<p>: CHS , S CR</p> <p>↑ Status Read ↑ Object: COLD HEAD</p>
Response Example	<p>When all COLD HEADS (NO.1 ~ No.8) are OFF, the following message will appear.</p> <p>: CHS , S ; 0 , 0 , 0 , 0 , 0 , 0 , 0 , 0 , 0 CR</p> <p>↑ Error code No.: 0 ~ 8 0:OFF 1:ON</p> <p>When the compressor is OFF, all operating statuses are shown as "0" which means OFF. In CP operation mode, CH7 is always shown as "0".</p> <p>↑ Echo back</p>
Compressor Motor Current	
Command	<p>: CMP , I CR</p> <p>↑ Current Read ↑ Object: Compressor</p>
Response Example	<p>When the current is 20A, the following message will appear.</p> <p>: CMP , I ; 200 , 0 CR</p> <p>↑ Error code No.: 0 ~ 8 ↑ Real Time Current: 0 ~ 500 (x 0.1A) ↑ Echo back</p>

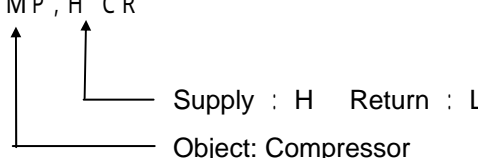
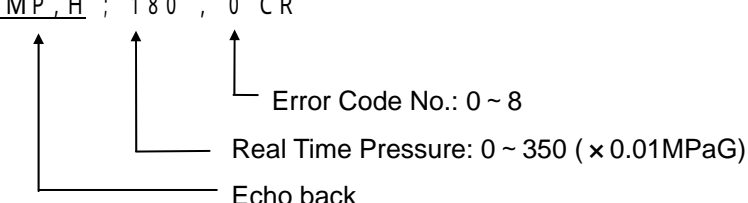
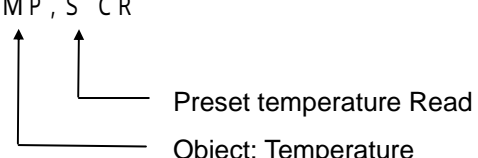
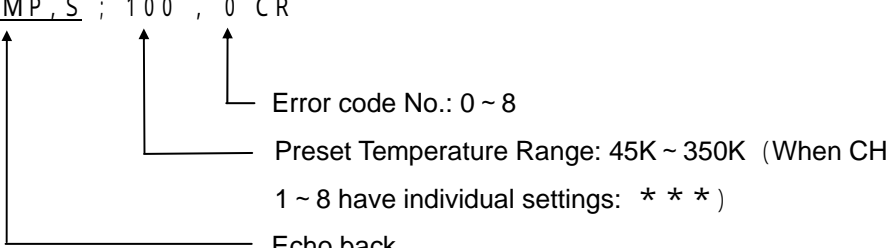
Compressor Unit Helium Gas Pressure	
Command	: <u>CMP</u> , <u>H</u> CR 
Response Example	When the helium gas supply pressure gauge reads 1.8MPaG, the following message will appear. : <u>CMP</u> , <u>H</u> ; 180 , 0 CR 
Preset Temperature (No.1 ~ 8 Collective Setting)	
Command	: <u>TMP</u> , <u>S</u> CR 
Response Example	When all COLD HEADS temperatures are preset to 100K, the following message will appear. : <u>TMP</u> , <u>S</u> ; 100 , 0 CR 

Preset Temperature (No.1 ~ 8 Individual setting)	
Command	<p>: TMP 1, S CR</p> <p>Preset Temperature Read Object: TMP1 ~ 8 correspond to No.1 ~ 8. ex) TMP1 indicates COLD HEAD No.1.</p>
Response Example	<p>When COLD HEAD No.1 temperature is preset to 100K, the following message will appear.</p> <p>: TMP 1, S ; 100 , 0 CR</p> <p>Error code No.: 0 ~ 8 Preset Temperature Range: 45K ~ 350K Echo back</p>
COLD HEAD Ready Status	
Command	<p>: CHD, S CR</p> <p>Status Read Object: COLD HEAD</p>
Response Example	<p>When all COLD HEAD are not in READY status, the following message is showed.</p> <p>: CHD, S ; 0, 0, 0, 0, 0, 0, 0, 0, 0 CR</p> <p>Error code No.: 0 ~ 8 0: NOT READY 1: READY Echo back</p> <p>NOTE: READY status is a state within the preset temperature + READY setting (default: 20K).</p>

3 Error Codes (Status No.0 ~ 8)

0 : No error

1 : Increased temperature

- The thermo protective switch (TS1, TS2, TS3) on the compressor unit is active.

2 : Abnormal pressure

- Low-Pressure Switch (LPS) is active.

4 : Abnormal Current

- Current overload protection for compressor (Thermal relay : CP3) is active.
- Circuit protector of refrigerator unit (CP2) has turned OFF.
- The current value of the compressor has exceeded its setting (default: 28.0A).

8 : Other than those above

- (If more than one errors (except for No.8) occurs at the same time, the total of the error numbers will be shown (0 ~ 8).)

4 Communication Time-out

- If a formal message does not sent within 3 seconds (or approx. 10 seconds when DIP switch No.7 is ON), the message will not be accepted.
- A command must start with ":"(start character) and end with "CR"(delimiter). Incorrect command will be neglected.
- When there is no reply, perform Time-Out processing from host computer and resend the command.

This page intentionally left blank.

Appendix C

FLEXIBLE HOSE

1. Specifications

- Gas : Helium Gas (Purity of 99.999% or above)
- Pressure : Maximum 2.45MPaG

<Note> The content of “Specifications and Drawings” specific to your system supersedes, if provided.

- Temperature : 0 to 70°C
- Material : SUS304
- Length : 3000mm (standard)
- Minimum Bending Radius : 250mm
- Recommended Torque for Connecting : 20N·m

<Note> Fasten the self-sealing coupling until fully tight.

- Connection : 1/2B self-sealing coupling

2. Handling Precautions



CAUTION

- When carrying a flexible hose, hold the braid support of the hose. Bending the flexible part forcibly at an acute angle may damage the hose.
- Do not twist a flexible hose especially when making continuously bent connections.
- Keep away from water and salt to prevent corrosion. Do not place heavy objects on flexible hoses in order to prevent deformation or collapse.

This page intentionally left blank

Appendix D

FLOW DIAGRAM

Low pressure helium gas returning from the refrigerator unit enters the compressor. Lubricant oil is injected into the compressor with the low pressure helium; the gas containing the oil is then compressed by the compressor pump turning it into high temperature high pressure helium gas. Most of the lubricant oil returns to droplet form and is separated within the compressor. This lubricant oil is pooled at the bottom and lubricates the inside of the compressor. It follows the circulating system where it comes out from the compressor and cooled down at an oil heat exchanger before being injected back into the compressor through an oil injection filter.

High temperature high pressure helium gas comes out from the compressor, passes through a water cooled helium heat exchanger for removal of compression-caused heat. It is cooled to an ambient temperature and then enters an oil separator. In here, the oil is separated and the droplets of separated oil pass thorough an oil return filter and oil return orifice before joining the low pressure helium gas and being returned to the compressor. High pressure helium gas comes out from the oil separator enters an adsorber where oil-mist is adsorbed and removed. The Helium gas comes out the adsorber passes through a flexible hose and is supplied to the refrigerator unit.

◆ Compressor safety devices

Name	Function	Specification
Pressure relief valve ※1	Located on the helium supply line and releases gas automatically when pressure exceeds the set value.	Set pressure : 2.85MPaG (413psig)
Differential pressure regulating valve	Located on the line connecting helium supply and return lines and automatically keeps the high – low differential pressure under the set value.	Set pressure : 1.74MPa (250psi)

※1 The set pressure of pressure relief valve at the refrigerator is 1.9MPaG. Please note that the refrigerator pressure relief valve releases gas before the compressor pressure relief valve in actual system.

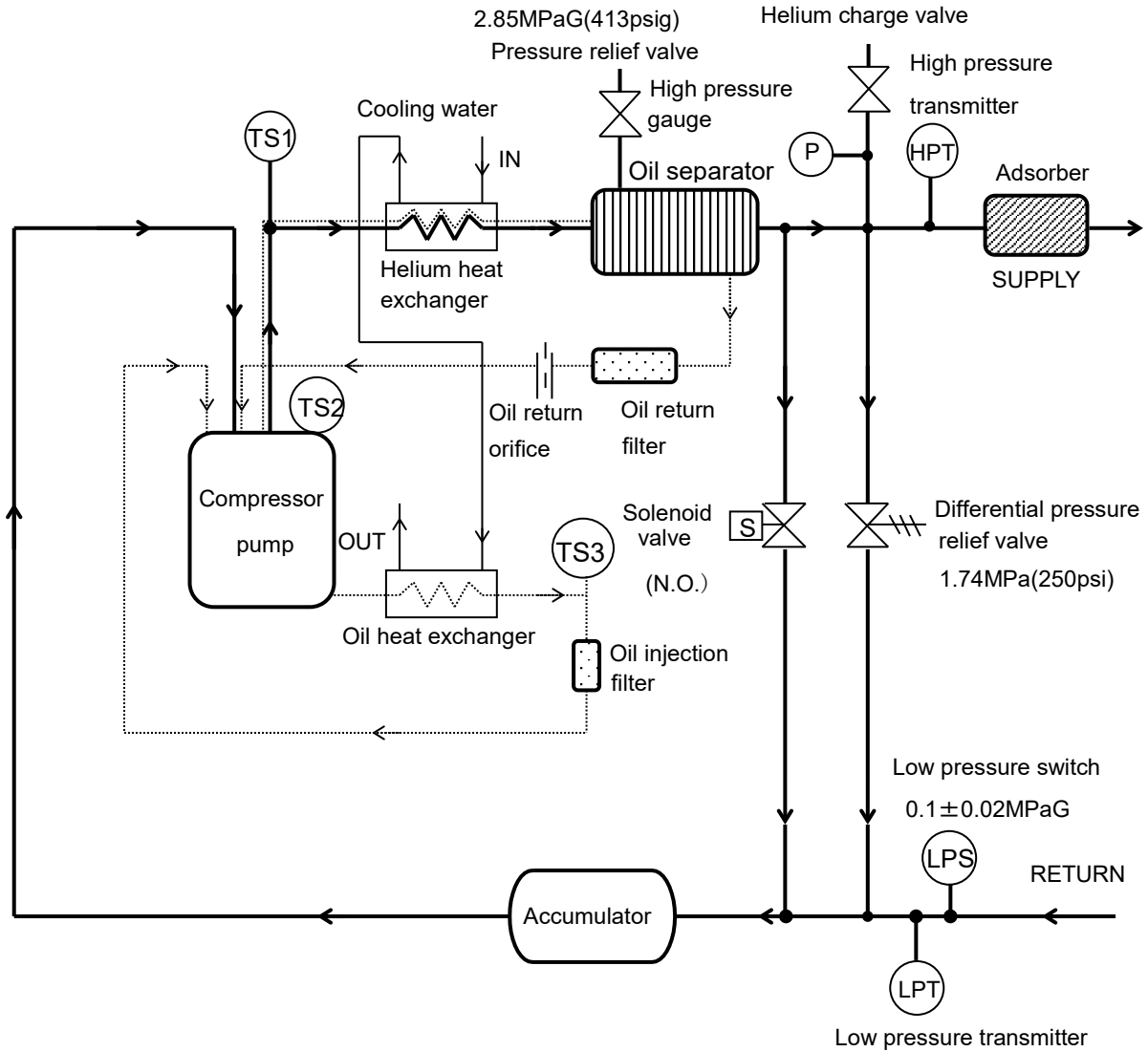

- Helium gas flow
- Helium gas + Oil flow
- Oil flow
- Cooling water flow

Figure D-1 C30PZ Flow Diagram

SERVICE NETWORK

- For technical support, servicing or additional contact information, visit us at www.ulvac-cryo.com.

ULVAC CRYOGENICS INC.

www.ulvac-cryo.com

1222-1 Yabata, Chigasaki, Kanagawa 253-0085, Japan

<Sales>

Tel: +81-467-85-8884

<Service Engineering Division>

Tel: +81-467-85-9366

Fax: +81-467-83-4838

ULVAC CRYOGENICS KOREA INC.

www.ulvac-cryo.co.kr

107, Hyeongoksandan-ro, Cheongbuk-Myeon, Pyeongtaek-si,
Gyeonggi-Do, Korea, 17812

Tel: +82-31-683-2926

Fax: +82-31-683-2956

ULVAC CRYOGENICS (NINGBO) INC.

www.ulvac-cryo.com

No.888 Tonghui Road, Jiangbei District, Ningbo, China, 315020

Tel: +86-574-879-03322

Fax: +86-574-879-10707

This page intentionally left blank.

Revision History

Date	Revision No.	Contents
2007-12-20	2007.12	First edition.
2008-04-10	2008AL01	Page1-2 RS232C Connector type change.
2008-06-11	2008JE02	Page2-1 Correction of the quantity of single handed wrench.
2009-10-02	2009OR03	RM refrigerator has added.
2010-06-17	2010JE04	Full-fledged revision.
2011-02-14	2011FY05	Cover: Export control policy has been revised.
2011-04-25	2011AL06	Section 2.1 Shipping List The item “Gasket for Helium Coupling (Spare) × 4” in Table 2-1 Shipping list has been moved to Table 2-2 Optional parts. Section 4-1 DIP Switch Settings has been moved to section 4-5. Figure 4-2 DIP Switch default position has been added. Table 3-1 Recommended Cooling Water for Compressor Unit and allowable range of Conductivity has been changed.
2013-03-26	2013MH07	“Safety Instruction” No.3 and No.5 have been revised. “SERVICE NETWORK” has been revised.
2013-11-05	2013NR08	“Introduction” has been revised. “SERVICE NETWORK” has been revised.
2015-06-09	2015JE09	“Compressor Unit Safety Instructions” has been revised. Section 6.3 Charging Helium Gas The description on charging procedure has been modified. Appendix B “3.4 Message Formats” The table has been modified.
2018-02-19	2018FY10	“1. Compressor Description” has been modified. “Service Network” has been revised.
2023-08-04	2023AT11	“Safety Instructions” Description on the sealing sticker has been added.
2023-11-09	2023NR12	“Safety Instructions” Description on the adsorber disposal has been modified. “Appendix C” A note has been added to flexible hose allowable pressure. “Appendix D” has been modified.

This page intentionally left blank