

**REGENERATION GAS PURGE
PR UNIT
Instruction Manual**

Export Control Policy

We recommend that ALL customers be sure to follow all rules and regulations such as Foreign Exchange and Foreign Trade Law when exporting or reexporting our products.

Introduction

Thank you for choosing our products. This instruction manual gives information and precautions on handling, installation, operation, and maintenance of the product.

This product is intended for use by qualified personnel who recognize shock hazards and are familiar with the safety precautions required to avoid possible injury. To ensure proper use of this product, read this instruction manual carefully and keep this manual close at hand so that you can use for reference during operation.

If you purchased our other products and/or optional devices with this product, read relevant instruction manuals carefully.

1. About the personnel who are involved in handling our products

All personnel involved in handling our products should take a general safety education and training that is officially accepted in the country where our product is used. The personnel are also required to have specialized knowledge/skills and qualification on the electricity, the machinery, the cargo handling, and the vacuum. Especially, the personnel should be familiar with handling a cryopump in order to use it safely. Since we offer a training session (which is subject to fees) as needed for people who use cryopumps for the first time, please do not hesitate to contact our Service Engineering Division to join the training session.

2. Warranty

2.1 Gratis warranty period and Warranty coverage

【Gratis warranty period】

Note that an installation period of less than one year after installation in your company or your customer's premises or a period of less than 18 months (counted from the date of production) after shipment from our company, which is shorter, is selected.

【Coverage】

(1) Failure diagnosis

As a general rule, diagnosis of failure should be done on site by customer.

However, ULVAC CRYOGENICS or our service network can perform this service for an agreed fee upon the customer's request. There will be no charge if the cause

of the breakdown is found to be a fault of ULVAC CRYOGENICS.

(2) Damage during transportation

When damage by delivery/transportation is admitted, the product will be repaired free of charge within the range of the guarantee expressed in the sales contract.

(3) Breakdown repairs

There will be a charge for breakdown repairs, replacements and on-site visits for the following seven conditions. In those cases the cost shall be your own expense even though the product is within the warranty period.

- ① Breakdowns due to improper storage or handling, careless accident, software or hardware design by the customer.
- ② Breakdowns due to modifications of the product without consent of the manufacturer.
- ③ Breakdowns due to maintenance of the product without authentic parts or breakdowns resulting from using the product outside the specified specifications of the product.
- ④ Breakdowns due to contamination or corrosion caused by user's use conditions.
- ⑤ Breakdowns due to natural disasters (such as fire, earthquake, flood, lightning, salt damage, and so on) , environmental pollution, irregular voltage, and /or usage of undesignated power source.
- ⑥ Breakdowns that are outside the terms of warranty.
- ⑦ Consumables and/or replacement service.

Since the above services are limited to within Japan, diagnosis of failures, etc are not performed abroad. If you desire the after service abroad, please contact ULVAC CRYOGENICS and consult us for details in advance.

2.2 Exclusion of opportunity loss from warranty liability

Regardless of the gratis warranty term, compensation to opportunity losses incurred to your company or your customers by failures of ULVAC CRYOGENICS products and compensation for damages to products other than ULVAC CRYOGENICS products and other services are not covered under warranty.

2.3 Repair period after production is discontinued

ULVAC CRYOGENICS shall accept product repairs for seven years after production of the product is discontinued.

3. Service Form

After the products are delivered, please fill out the following information in the blanks. If you have any questions or technical problems, please feel free to contact the nearest Customer Support Center or headquarters. Please refer to "Service Network".

Cryopump/Super trap Model	:	_____
Cryopump/Super trap Serial No.	:	_____
Refrigerator Model	:	_____
Refrigerator Serial No.	:	_____
Compressor Model	:	_____
Compressor Serial No.	:	_____
Temperature controller/Thermal display Model	:	_____
Temperature controller/Thermal display Serial No.	:	_____
Option Part Model	:	_____
Optional Part Serial No.	:	_____

4. Notes for repair and maintenance requests

We may decline your request for the repair or the maintenance of our products if you refuse to give us information about the presence of the hazardous substance and/or contaminant.

Also, please be aware that we do not accept liability for damages by the contaminant, which might be caused during transportation to our office or the nearest customer support center. To avoid such accident, please pay careful attention to packing of the product

5. In case of breakdown and accident

When breakdown or accident occurs, we may ask for keeping the product on site as it is or retrieving the product to investigate its cause. Also we may ask for reporting the detailed process and/or the operating condition. When unidentified malfunction was generated, please contact our Service Engineering Division or

the nearest customer support center with reference to the chapter of Service Network. We ask for cooperation about the above.

6. General Precautions

- (1) It is strictly prohibited to duplicate, open, and transfer this instruction manual or any of its parts to a third person without written permission from ULVAC CRYOGENICS.
- (2) Information in this document might be revised without a previous notice for the specification change and the improvement of the product.
- (3) If you have any questions or comments on this document, please do not hesitate to contact us. The phone numbers of local customer support centers are listed at the end of this manual.

Safety Considerations

Our products have been designed to provide extremely safe and dependable operation when properly used. Following safety precautions must be observed during normal operation and when servicing them.

**WARNING**

A warning describes safety hazards or unsafe practices which could result in severe injury or loss of life.

**CAUTION**

A caution describes safety hazards or unsafe practices which could result in personal injury or equipment damage.

**Toxic gas or chemicals used.**

There is a risk of severe injury upon contact.

**Corrosive chemicals used.**

There is a risk of severe injury upon contact.

**Flammable gas used.**

There is a danger of fire or burn injury.

**Explosive gas used.**

There is a risk of fire or explosion.

**Hazardous voltage .**

Electric shock may cause severe injury or loss of life.

**Hot heating part present.**

There is a risk of burn injury.

This page intentionally left blank

Disposal Considerations

Disposal of our products must be done in accordance with applicable national and local laws and regulations.

				WARNING
<p>The cryopumps or cryocoolers may contain residue of hazardous substances resulting from actual use. Contact your safety supervisor and follow the instructions to remove such toxic substances before disposing.</p>				

We provide Safety Data Sheet (SDS) of our products upon your request.
Please contact us if necessary.

This page intentionally left blank.

TABLE OF CONTENTS

SECTION 1	Description.....	1
SECTION 2	Specifications	1
SECTION 3	Installation	3
SECTION 4	Operation	7
SECTION 5	Troubleshooting	8

FIGURES & TABLES

Figure	1	Regeneration Gas Purge PR Unit Dimensions	2
	2	Direction Change of the Lead Wire Port	3
	3	Inner Structure of the Atmospheric Sensor	5
	4	Pressure Loss of Regeneration Gas Purge PR Unit	6
Table	1	Fault Diagnosis	8

This page intentionally left blank

1. Description

- Regeneration Gas Purge PR Unit enables to introduce and exhaust gases through a port of a cryopump.
- By utilizing heat conduction effect of purge gas, it speeds up melting of the condensed gases, thus shorten the warm up time compare to the natural warm up of vacuum locked cryopump.
- By introducing inert N₂ purge, evacuates remaining water from the cryopump and shortens the roughing time.

2. Specifications

(1) Solenoid Valve

Manufacturer	CKD Corporation
	Type: HVB612-12F-8B
Voltage	DC24V (Standard), Power 14.3W
	AC100V and AC200V are optional.
Dielectric strength	Heat-resisting class B (JIS C4003)
Valve seal leakage	1×10^{-9} Pa · m ³ /s or less (7.5×10^{-9} Torr · L/s or less) ※
External leakage	1×10^{-9} Pa · m ³ /s or less (7.5×10^{-9} Torr · L/s or less) ※
	※The above leakages are the values obtained after spraying He gas for 10 seconds in the normal temperature, and the leakage which penetrates rubber is not contained.
Cv Rate	1.8 (Straight) , 2.1 (L direction)
O-ring.....	V24 (JIS B2401)
Fluid.....	Inert gas
Operating Pressure.....	$1.3 \times 10^{-6} \sim 2 \times 10^5$ Pa
Maximum Pressure.....	2×10^2 kPa
Backing Pressure	1×10^2 kPa
Fluid Temperature	5~55°C
Ambient Temperature.....	0~55°C
Flange	φ 48
Temperature rise.....	Approx. 75°C

(2) Atmospheric Sensor

Supplier	ULVAC, Inc.
	Type: DTA-002
Rated Current ·	UL·CSA/5A-250VAC
	(Resistance load 5A, Induction load 3A)

Method..... Bellows (The limit switch will activates at the point when the bellows becomes free length)
 Dimensions..... $\phi 52 \times 83$ (H)
 Leakage rate..... $1 \times 10^{-9} \text{Pa} \cdot \text{m}^3/\text{s}$ or less ($7.5 \times 10^{-9} \text{Torr} \cdot \text{L/s}$ or less)

(3) Regeneration Piping

Piping with C type rotating flange

(C type rotating flange is exclusive design for ULVAC CRYOGENICS Inc.)

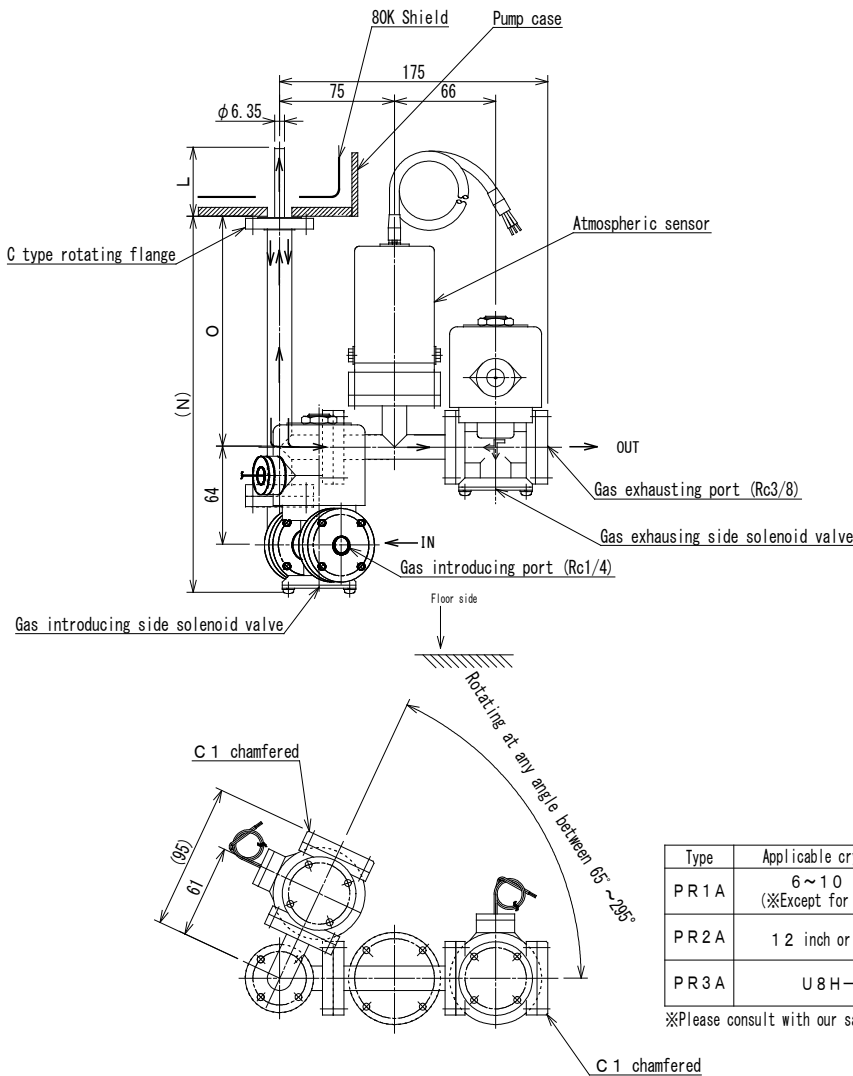

Type	Applicable cryopump model	L	O	N
PR 1 A	6 ~ 1.0 inch (※Except for U 8 H-U)	35	32	128
PR 2 A	1.2 inch or larger size	45	150	246
PR 3 A	U 8 H-U	165	150	246

※Please consult with our sales representative about a horizontal type (L shaped type) pump.

Figure 1 Regeneration Gas Purge PR Unit Dimensions

3. Installation

- (1) Remove the C type flange from the pump case and install the regeneration gas purge PR unit to the place specified on the cryopump external drawing. Conduct a helium leak test after the installation.



CAUTION

Install the PR unit to the hole on the 80K shield inside the cryopump.
(There are some exceptional pump models)

- (2) Connect the electrical wiring for the solenoid valve and atmospheric sensor.

◆Wiring of the solenoid valve

This solenoid valve closes when de-energized and opens when energized.

The lead wires are not terminated when they are shipped. Attach an appropriate connector to the two lead wires from the solenoid valve and connect it to the power circuit which supplies a specified power voltage. The power circuit wire should have 0.5mm² or larger of nominal cross-sectional area. Twist the lead wires. Voltage specifications are indicated on the nameplate of the solenoid valve (upper part of the solenoid valve).

As shown in Figure 2, the lead wire port of the solenoid valve can be rotated by loosen the hexagon nut at the top of the valve. If the solenoid valve touches any object of the equipment, rotate the port and adjust the position. After adjusting the position of the lead wire port, tighten the nut at the specified torque. The tightening torque of the hexagon nut is 10N · m.

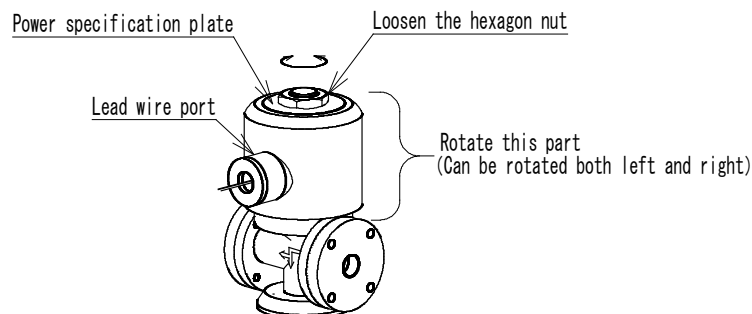

Figure 2 Direction Change of the Lead Wire Port

**CAUTION**

- The arrows marked on the side of the solenoid valve are not the direction of gas flow. The right side of the flat end is atmospheric pressure (0.2MPa maximum) area and the area to which the arrows pointed are vacuum area.

◆ Wiring of the atmospheric sensor

The wire (nominal cross-sectional area 0.5mm², AWG20 equivalent) comes out from the cover is not terminated. Prepare an appropriate connector and connect it to the control devices at the equipment side. Clamp the wire not to put a load on the wire end.

The bellows inside the atmospheric sensor shrinks in vacuum and the top of the bellows and the contact switch will be detached that makes the line between COM (lead wire coating: red) and NC (lead wire coating: black) energized. When it becomes atmospheric pressure, the bellows inside the sensor returns to free length and the top of the bellows touches contact switch that makes the line between NC (lead wire coating: red) and NO (lead wire coating: white) energized. Check that it works properly with a tester before using the sensor. To check the atmospheric pressure, connect COM-NO to the control devices.

◆ Adjusting the atmospheric sensor

1. Loosen the two M5 hexagon bolts fixing the cover of the atmospheric sensor. Remove the cover by lifting it up.
2. In atmospheric pressure, the contact switch is touching the bellows. Check that the contact switch and the bellows are in proper positions. In case of the switch has no contact with the bellows, adjust the position of the M5 hexagon nut using a spanner (width across 8mm). Make sure that the bellows are free length at this point. The tightening torque of M5 hexagon nut is 3N · m.
3. Put the cover back and tighten the M5 hexagon bolts at a specified torque. The tightening torque of the M5 hexagon bolt is 3N · m.

Do not put a load on
the wire end

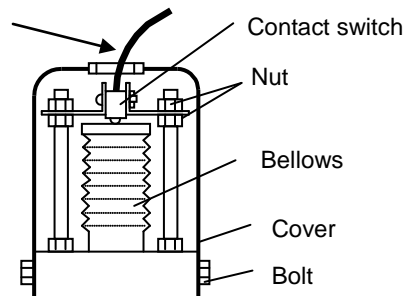

Figure 3 Inner Structure of the Atmospheric Sensor



CAUTION

- Before the shipment, the atmospheric sensor is adjusted so that the top of the bellows will touch the contact switch in atmospheric pressure. In case that atmospheric pressure and vacuum state switches frequently, the bellows may shrink. Adjust the positions of the bellows and contact switch regularly when the cryopump has been stopped (for equipment maintenance overhaul).
- Install the atmospheric sensor should be installed vertically upward. If it is installed horizontally or vertically downward, it may not work properly.

◆ Connecting gas inlet and outlet lines

The gas inlet side solenoid valve flange is tapped Rc1/4 and the gas outlet side solenoid valve flange is tapped Rc3/8. Connect the gas introduction line and exhaust line according to the following cautions.



CAUTION

1. The gas flow rate for the gas inlet line should be 20NL/min ~ 50NL/min.
2. If the pressure in a cryopump exceeds 10~20kPaG, a safety valve will operate. Choose an appropriate size and length of the gas purge pipe in order to maintain the pressure loss in the entire purge gas introduction line to be 5kPaG or less at the set flow rate. (Refer to Figure 4)
3. Choose and install the piping of the gas exhaust line carefully to keep the pressure loss minimum.

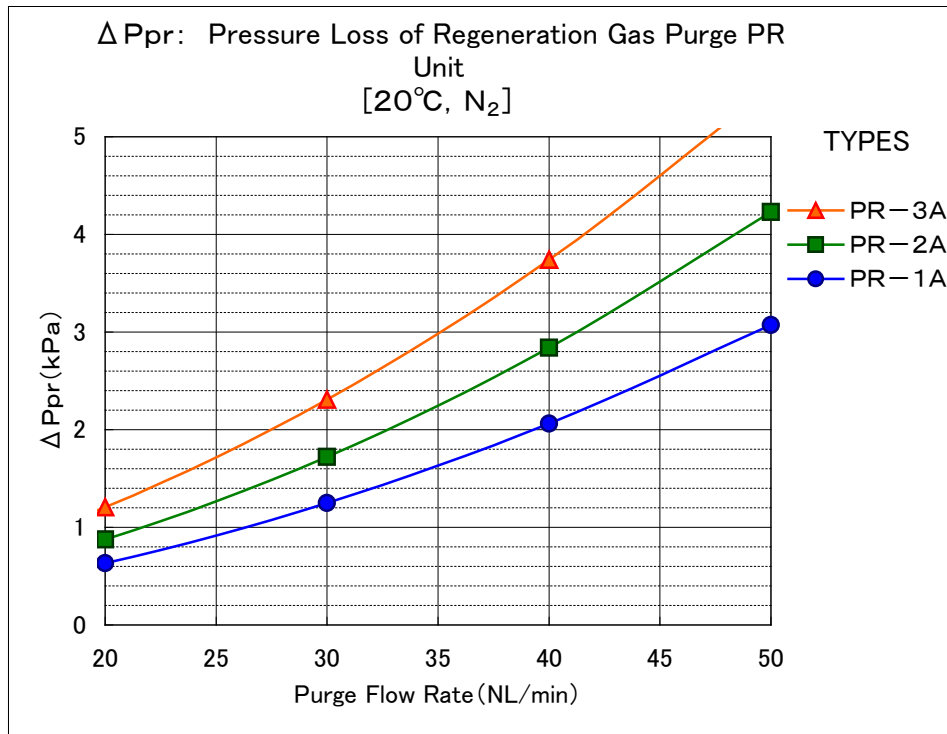

Figure 4 Pressure Loss of Regeneration Gas Purge PR Unit



CAUTION

- The solenoid flanges are exclusive products. (Not JIS standard products)
- Up to Ø18mm pipe (maximum) can be welded by modifying the flanges.
- The flanges are chamfered on both sides. The narrower chamfered side is for O-ring seat.

4. Operation

1. Turn OFF the cryopump system.
2. Turn ON the solenoid valve for gas inlet and introduce the gas into the cryopump.
3. When the pressure inside the cryopump reached atmospheric pressure, turn ON the solenoid valve for gas outlet and release the gas.

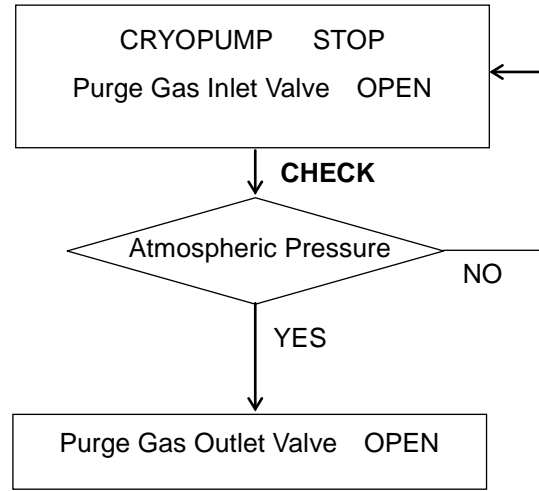

Operation Flow Chart



CAUTION

The solenoid valve becomes very hot (about 75°C) when it is energized.
Take appropriate measures to avoid burn injury.

5. Troubleshooting

Table 1 shows the possible cause and corrective actions to solve problems.

Please contact us when the cause can't be identified.

Table 1 Fault Diagnosis

Problem	Possible cause	Corrective action
Atmospheric sensor does not operate even though the pressure has reached to atmospheric pressure.	Contact point switch is not in a proper position.	Remove the cover of the atmospheric sensor and confirm that the contact point switch is in the right position. (The position should be adjusted regularly.)
	Miswiring	Connect the cable correctly.
The solenoid valve does not operate.	Miswiring	Connect the cable correctly.
	Fault of electric power.	Check that the power source is supplied properly.
Solenoid valve leakage.	Coil failure.	Please contact our Service Engineering Division or the nearest customer support center.
	Substances are sticking to the solenoid valve sheet and damaged it.	Solenoid valve needs replacement. After a replacement, set a filter at the inlet of the solenoid valve. (Please contact our Service Engineering Division or the nearest customer support center.)

SERVICE NETWORK

- For technical support, servicing or additional contact information, visit us at www.ulvac-cryo.com.

ULVAC CRYOGENICS INC.

www.ulvac-cryo.com

1222-1 Yabata, Chigasaki, Kanagawa 253-0085, Japan

<Sales>

Tel: +81-467-85-8884

<Service Engineering Division>

Tel: +81-467-85-9366

Fax: +81-467-83-4838

ULVAC CRYOGENICS KOREA INC.

www.ulvac-cryo.co.kr

107, Hyeongoksandan-ro, Cheongbuk-Myeon, Pyeongtaek-si,
Gyeonggi-Do, Korea, 17812

Tel: +82-31-683-2926

Fax: +82-31-683-2956

ULVAC CRYOGENICS (NINGBO) INC.

www.ulvac-cryo.com

No.888 Tonghui Road, Jiangbei District, Ningbo, China, 315020

Tel: +86-574-879-03322

Fax: +86-574-879-10707

This page intentionally left blank.

Revision History

Date	Revision No.	Contents
2006-01-30	2006.01	First edition
2006-12-14	2006DR01	The type of the solenoid valve has changed.
2007-09-05	2007SR02	Addition of disposal consideration. (PIW-1)
2009-06-08	2009JE03	“Introduction” has revised.
		UCN address has changed.
		“SERVICE NETWORK” has revised.
2010-05-26	2010MY04	The type of the solenoid valve has changed.
2010-06-10	2010JE05	The size of screw on the outlet solenoid valve attachment
		flange has been unified into Rc3/8.
2012-08-02	2012AT06	Full-fledged revision.
2013-11-08	2013NR07	“Introduction” has been revised.
		“SERVICE NETWORK” has been revised.
2018-12-13	2018DR08	“SERVICE NETWORK” has been revised.

This page intentionally left blank