

RBH Band Heater

Instruction Manual

Export Control Policy

We recommend that ALL customers be sure to follow all rules and regulations such as Foreign Exchange and Foreign Trade Law when exporting or reexporting our products.

Introduction

Thank you for choosing our products. This instruction manual gives information and precautions on handling, installation, operation, and maintenance of the product.

This product is intended for use by qualified personnel who recognize shock hazards and are familiar with the safety precautions required to avoid possible injury. To ensure proper use of this product, read this instruction manual carefully and keep this manual close at hand so that you can use for reference during operation.

If you purchased our other products and/or optional devices with this product, read relevant instruction manuals carefully.

1. About the personnel who are involved in handling our products

All personnel involved in handling our products should take a general safety education and training that is officially accepted in the country where our product is used. The personnel are also required to have specialized knowledge/skills and qualification on the electricity, the machinery, the cargo handling, and the vacuum. Especially, the personnel should be familiar with handling a cryopump in order to use it safely. Since we offer a training session (which is subject to fees) as needed for people who use cryopumps for the first time, please do not hesitate to contact our Service Engineering Division to join the training session.

2. Warranty

2.1 Gratis warranty period and Warranty coverage

【Gratis warranty period】

Note that an installation period of less than one year after installation in your company or your customer's premises or a period of less than 18 months (counted from the date of production) after shipment from our company, which is shorter, is selected.

【Coverage】

(1) Failure diagnosis

As a general rule, diagnosis of failure should be done on site by customer.

However, ULVAC CRYOGENICS or our service network can perform this service for an agreed fee upon the customer's request. There will be no charge if the cause

of the breakdown is found to be a fault of ULVAC CRYOGENICS.

(2) Damage during transportation

When damage by delivery/transportation is admitted, the product will be repaired free of charge within the range of the guarantee expressed in the sales contract.

(3) Breakdown repairs

There will be a charge for breakdown repairs, replacements and on-site visits for the following seven conditions. In those cases the cost shall be your own expense even though the product is within the warranty period.

- ① Breakdowns due to improper storage or handling, careless accident, software or hardware design by the customer.
- ② Breakdowns due to modifications of the product without consent of the manufacturer.
- ③ Breakdowns due to maintenance of the product without authentic parts or breakdowns resulting from using the product outside the specified specifications of the product.
- ④ Breakdowns due to contamination or corrosion caused by user's use conditions.
- ⑤ Breakdowns due to natural disasters (such as fire, earthquake, flood, lightning, salt damage, and so on) , environmental pollution, irregular voltage, and /or usage of undesignated power source.
- ⑥ Breakdowns that are outside the terms of warranty.
- ⑦ Consumables and/or replacement service.

Since the above services are limited to within Japan, diagnosis of failures, etc are not performed abroad. If you desire the after service abroad, please contact ULVAC CRYOGENICS and consult us for details in advance.

2.2 Exclusion of opportunity loss from warranty liability

Regardless of the gratis warranty term, compensation to opportunity losses incurred to your company or your customers by failures of ULVAC CRYOGENICS products and compensation for damages to products other than ULVAC CRYOGENICS products and other services are not covered under warranty.

2.3 Repair period after production is discontinued

ULVAC CRYOGENICS shall accept product repairs for seven years after production of the product is discontinued.

3. Service Form

After the products are delivered, please fill out the following information in the blanks. If you have any questions or technical problems, please feel free to contact the nearest Customer Support Center or headquarters. Please refer to "Service Network".

Cryopump/Super trap Model	:	_____
Cryopump/Super trap Serial No.	:	_____
Refrigerator Model	:	_____
Refrigerator Serial No.	:	_____
Compressor Model	:	_____
Compressor Serial No.	:	_____
Temperature controller/Thermal display Model	:	_____
Temperature controller/Thermal display Serial No.	:	_____
Option Part Model	:	_____
Optional Part Serial No.	:	_____

4. Notes for repair and maintenance requests

We may decline your request for the repair or the maintenance of our products if you refuse to give us information about the presence of the hazardous substance and/or contaminant.

Also, please be aware that we do not accept liability for damages by the contaminant, which might be caused during transportation to our office or the nearest customer support center. To avoid such accident, please pay careful attention to packing of the product

5. In case of breakdown and accident

When breakdown or accident occurs, we may ask for keeping the product on site as it is or retrieving the product to investigate its cause. Also we may ask for reporting the detailed process and/or the operating condition. When unidentified malfunction was generated, please contact our Service Engineering Division or

the nearest customer support center with reference to the chapter of Service Network. We ask for cooperation about the above.

6. General Precautions

- (1) It is strictly prohibited to duplicate, open, and transfer this instruction manual or any of its parts to a third person without written permission from ULVAC CRYOGENICS.
- (2) Information in this document might be revised without a previous notice for the specification change and the improvement of the product.
- (3) If you have any questions or comments on this document, please do not hesitate to contact us. The phone numbers of local customer support centers are listed at the end of this manual.

Safety Considerations

Our products have been designed to provide extremely safe and dependable operation when properly used. Following safety precautions must be observed during normal operation and when servicing them.

**WARNING**

A warning describes safety hazards or unsafe practices which could result in severe injury or loss of life.

**CAUTION**

A caution describes safety hazards or unsafe practices which could result in personal injury or equipment damage.

**Toxic gas or chemicals used.**

There is a risk of severe injury upon contact.

**Corrosive chemicals used.**

There is a risk of severe injury upon contact.

**Flammable gas used.**

There is a danger of fire or burn injury.

**Explosive gas used.**

There is a risk of fire or explosion.

**Hazardous voltage .**

Electric shock may cause severe injury or loss of life.

**Hot heating part present.**

There is a risk of burn injury.

This page intentionally left blank

Disposal Considerations

Disposal of our products must be done in accordance with applicable national and local laws and regulations.

				WARNING
<p>The cryopumps or cryocoolers may contain residue of hazardous substances resulting from actual use. Contact your safety supervisor and follow the instructions to remove such toxic substances before disposing.</p>				

We provide Safety Data Sheet (SDS) of our products upon your request.
Please contact us if necessary.

This page intentionally left blank.

TABLE OF CONTENTS

1. Features..... 1

2. Specifications..... 2

 2.1 Dimensions and Electric Current..... 2

 2.2 Power Consumption and Surface Temperature Characteristic 3

 2.3 Heater Specifications 3

3. Connector Specification 4

 3.1 Pin Connector 4

 3.2 Attached Connector 4

4. Accessories..... 5

5. Installation 5

6. Operation..... 9

7. Troubleshooting..... 10

FIGURES

Figure 2-1 Power Consumption and Surface Temperature Characteristic 3

Figure 3-1 Pin Connector 4

Figure 3-2 Connection of the Pin Connector..... 4

Figure 5-1 Attaching RBH band heater to a pump case 5

Figure 5-2 Installation to L type Cryopump 6

Figure 5-3 Adjusting Bolt Installation..... 7

Figure 5-4 Hook the Clamp 7

Figure 5-5 Adjusting the Clamp..... 7

Figure 5-6 Fixing the Clamp Lever..... 8

TABLES

Table 2-1 Dimensions, Power Consumption, Applicable Cryopumps 2

Table 4-1 List of Accessories 5

Table 7-1 Fault Diagnosis..... 10

This page intentionally left blank

1. Features

- RBH band heater is a self-controlling heater which does not require a temperature controller.

The resistance increases as the temperature rises, and thereby the current and the power consumption decrease.

- Shortens warm-up time.

Warm up time can be shortened to one-third or half by using the RBH band heater with one of the regeneration methods; nitrogen purge until 2.7×10^3 Pa, quick regeneration utilizing inner heaters, or continuous nitrogen purge.

- Speed up water evaporation and shortens rough pumping time.
- The temperature of the pump case surface will be kept around 70°C and there will be no damage to a pump inner kit or a cold head by overheating.
- High reliability and easy operation. (Life time: 10000h)
- A range of cryopumps are available from 6 to 30 inches.

2. Specifications

2.1 Dimensions and Electric Current

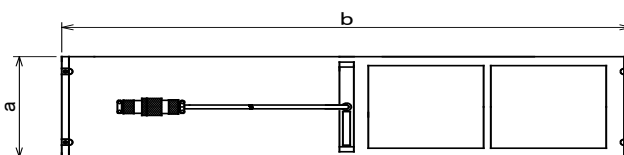

Table 2-1 Dimensions, Power Consumption, Applicable Cryopumps

MODEL	Dimensions (mm)		Current* ¹⁾ (A)		Fuse (A)	CRYOPUMP
	a	b	Max.	Normal		
RBH-6	170	495	1.3	0.2	5	U6H
RBH-6HL	145	465	1.0	0.2	5	U6HL
RBH-8	170	650	1.5	0.4	5	U8H,U8H-U
RBH-8HL	170	540	1.3	0.2	5	U8HL
RBH-8HSP	170	790	2.7	0.4	5	U8HSP
RBH-10	170	850	2.7	0.4	5	U10PU,U10PUS,U10H,U10HSP
RBH-10HL	170	850	1.5	0.3	5	U10HL
RBH-10HL(UFC/ICF)	150	850	1.5	0.3	5	U10HL (UFC/ICF Flange Type)
RBH-12	190	940	2.9	0.6	5	U12H,U12HSP
RBH-12HL* ²⁾	190	864	2.9	0.6	5	U12HL,U12HSPL
RBH-14	190	1212	2.9	0.6	5	U14H
RBH-16	260	1290	5.0	0.9	10	U16,U16P,U16HSP
RBH-16HSP	260	1290	5.0	0.9	10	U16HSP
RBH-16L* ²⁾	260	1150	5.0	0.9	10	U16L,U16PL
RBH-16HSPL* ²⁾	260	1150	5.0	0.9	10	U16HSPL
RBH-18	260	1520	6.0	1.0	10	U18H
RBH-20	260	1665	7.5	1.5	10	U20P,U20H,U20HSP
RBH-20HL/BL	297	1653	9.0	1.8	20	U20HL,U20BL,U20BLM
RBH-22	302	1900	11.5	2.0	20	U22H
RBH-22P	260	1900	8.3	1.7	20	U22P
RBH-22B	260	1900	8.3	1.7	20	U22B
RBH-22BL	260	1900	8.3	1.7	20	U22BL
RBH-22WB	260	1900	8.3	1.7	20	U22WB
RBH-26	302	2220	12.0	2.3	20	U26H
RBH-30	320	2525	14.6	2.7	30	U30H, U30HP

*1) Current value at AC200V. Secular distortion and bending may change the current within $\pm 10\%$.

*2) The shape of a clamp for 12HL series and 16L series is different from others

2.2 Power Consumption and Surface Temperature Characteristic

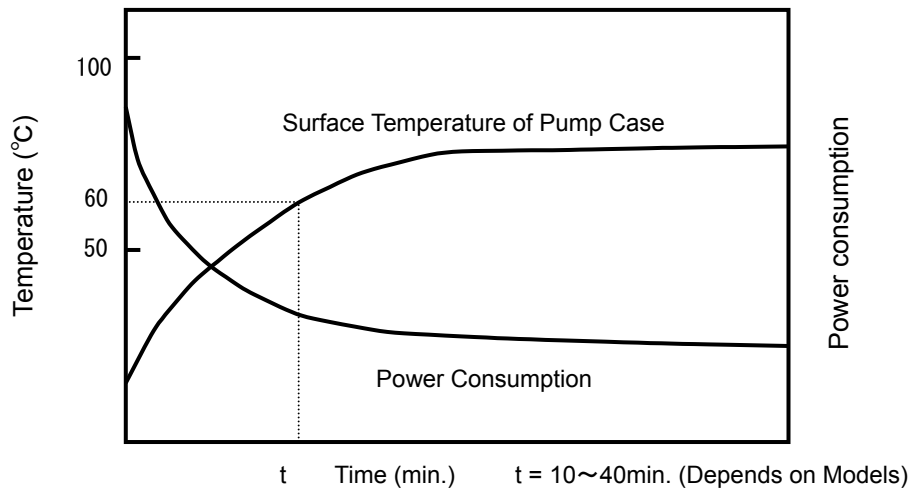

Figure 2-1 Power Consumption and Surface Temperature Characteristic

2.3 Heater Specifications

- ① Rated Voltage: AC200V \pm 10% \times 1 ϕ
- ② Surface Temperature: 80°C+10, -5°C
- ③ Life Time(Elapsed time applying current): 10000h
- ④ Insulation Resistance: DC500V, more than 100M Ω
- ⑤ Dielectric Strength: One minutes at AC1500V.



CAUTION

RBH band heaters can operate even at AC 100V \pm 10%, rated voltage. However, it will take approximately four times longer than that of AC200V \pm 10% to reach the maximum temperature.

3. Connector Specification (Manufactured by Nanaboshi Electric Mfg. Co., Ltd.)

3.1 Pin Connector (See Fig.2)

- ①RBH-6 - RBH-14 3 pin type : NCS-253-Ad
- ②RBH-16 - RBH-30 3 pin type : NCS-303-Ad

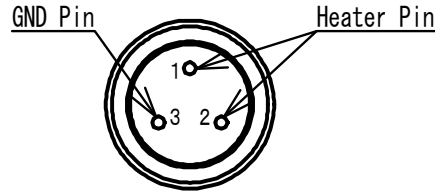

Figure 3-1 Pin Connector

3.2 Attached Connector (Cables are not included.)

- ①RBH-6 - RBH-14 3 pin type : NCS-253-P
- ②RBH-16 - RBH-30 3 pin type : NCS-303-P

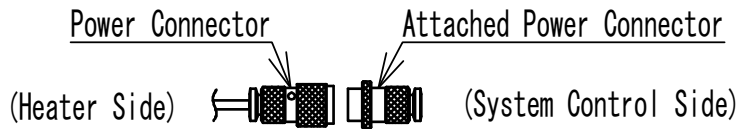

Figure 3-2 Connection of the Pin Connector

4. Accessories

Unpack the shipping cartons and check that there is no shortage of delivered items listed in Table 2 below as well as the attached connector described in Section 3.

Depending on the heater model, an RBH band heater will be mounted on a cryopump, before it is shipped.

Table 4-1 List of Accessories

Bolt	Quantity	Quantity of fixing nut	Applicable Cryopump
Cross Recessed Pan Head Screw M5x50L	2	2	U8H / U8H-U / U10H / U10HSP / U10HL / U10HL (UFC/ICF)
	3	3	U20P, U20H, U20HSP
Cross Recessed Pan Head Screw M5x60L	2	2	U8HSP / U8HL
Cross Recessed Pan Head Screw M5x75L	2	2	U6H / U6HL / U12H / U12HSP / U14H
	3	3	U16 / U16P / U18H / U20HL / U20BL / U20BLM
Cross Recessed Pan Head Screw M5x100L	3	3	U16HSP / U20P / U20H / U22H / U22P / U22B / U22BL / U22WB / U26H / U30H / U30HP
Cable Tie PLT1.5M-M8	2	/	U12HL / U12HSPL / U16L / U16PL / U16HSPL
	3		U20PL
Adjustment Bolt M5x215L	2	2	U12HL / U12HSPL / U16L / U16PL / U20PL
Adjustment Bolt M5x330L	2	2	U16HSPL

5. Installation

- As shown in Figure 4, loop the RBH band heater around the pump case, and then fasten it with attached bolts (cross-recessed pan head screws M5) until it does not fall off with its own weight.
First, put the bolt through the $\phi 6$ hole and then M5 tap. Then, tighten with a hexagon nut (M5).

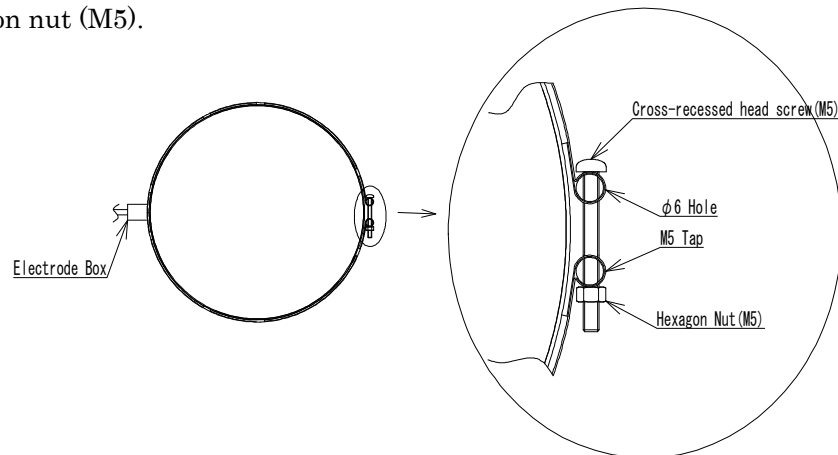

Figure 5-1 Attaching RBH band heater to a pump case

- Solder the power cable(customer-supplied) to attached connector (3 Pins).
Ensure to cover the soldered part with heat-shrinkable tube.

Fix the power cable to the clamp using cab tire cable or the like. Reinforce it with protective bushing.

Apply AC 200V ± 10%, rated voltage.

**CAUTION**

There is a mark, indicates SCN or SAC, around the power connector to inform that lead-free solder is used inside. Do not mix the lead-free soldering part with lead containing solder.

**CAUTION**

1. Do not forcibly bend the heaters since they are insulated by polyester cover.
2. When installing the heater to the pump case, make sure that the heater is fixed on hooks on the stainless board.
3. Tighten the screw to attach an RBH band heater to a pump case until it won't fall off with its own weight. Do not over tighten it otherwise it may break the substrate of the heater.
4. In case that water vapor condensed on outer surface of the pump case, do not place any connecting parts and power connector box under the pump case.
5. RBH band heaters can be operated at AC $100V \pm 10\%$, rated voltage. However, it will take approximately four times longer than that of AC $200V \pm 10\%$ to reach the maximum temperature.
6. Use gloves to handle RBH band heater to prevent your hand from being hurt by the sharp edge.
7. A part of the components of RBH band heaters contains material with -Si-O- linkage. If you prefer the product which does not generate siloxane gas, please contact us.

◆ Installation to L type Cryopump ◆

The method of installing RBH band heaters to L type cryopumps may differ from that of standard cryopumps, depending on the model of L type cryopumps. If you purchased an RBH band heater with a cryopump system, the heater will be mounted on the cryopump before it is shipped. However, if you purchased an RBH band heater alone, it should be installed at customer's facility as follows.

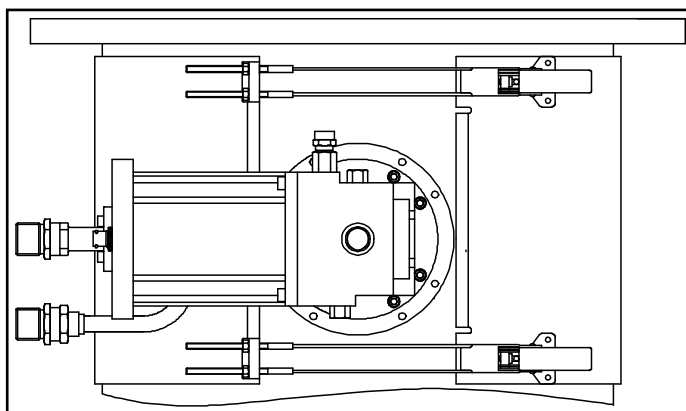

Figure 5-2 Installation to L type Cryopump

- (1) Put attached adjusting bolt(two or three) through two holes ($\phi 6$) and then fix with hexagon nuts temporarily.

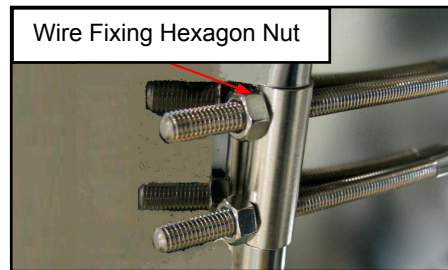

Figure 5-3 Adjusting Bolt Installation

- (2) Wrap the RBH band heater around the pump case. Hook the clamp through the wire of adjusting bolt, and then lock the lever by pushing it in the direction of the arrow as shown in Figure 7.

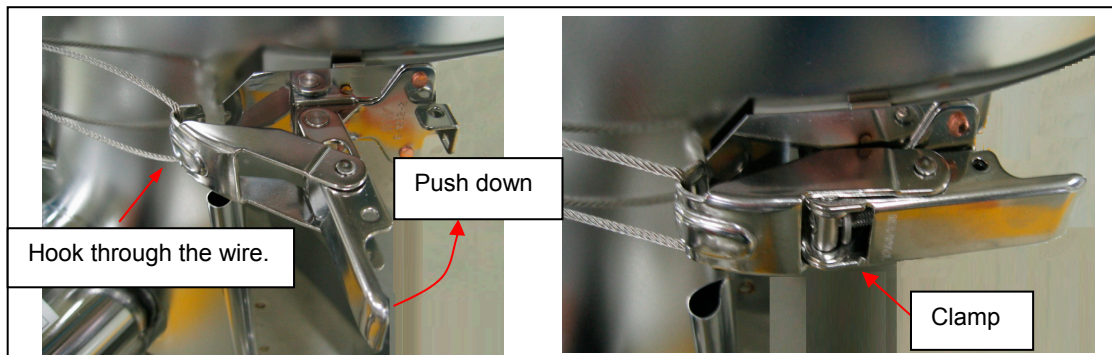

Figure 5-4 Hook the Clamp

- (3) Fix the RBH band heater by tightening M5 hexagon nut for fixing adjusting bolt until the band heater won't fall off by its weight. Then, fit the band heater to the pump case by tightening the M5 screws inside the clamp. Refer to Figure 9 and put a cable tie through the hole ($\phi 4$) on the clamp and pull it hard to fix the lever so that it won't stand or move. Cut the surplus cable tie.

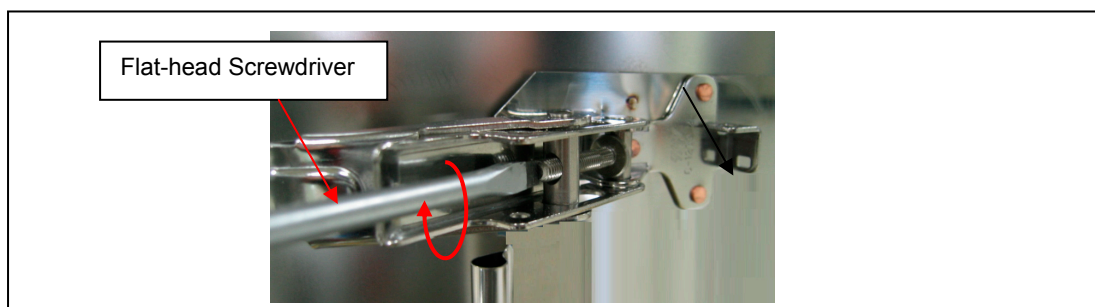

Figure 5-5 Adjusting the Clamp



Figure 5-6 Fixing the Clamp Lever

- (4) Solder the power cable(customer-supplied) to attached connector(3 Pins).
Ensure to cover the soldered part with heat-shrinkable tube.
Fix the power cable to the clamp using cab tire cable or the like.

Apply AC 200V \pm 10%, rated voltage.



CAUTION

There is a mark, indicates SCN or SAC, around the power connector to inform that lead-free solder is used inside. Do not mix the lead-free soldering part with lead containing solder.

6. Operation

- (1) Power ON the RBH band heater when regeneration of the cryopump has started.
- (2) Power OFF the RBH band heater when rough pumping of the cryopump has finished.

«EXAMPLE»

Inside the Cryopump: Start N₂ gas purge and power ON the RBH band heater at the same time.

Inside the Cryopump: Room Temperature

Inside the Cryopump: Power OFF the RBH band heater when rough pumping has completed (40Pa).



CAUTION

There is a risk of burn injury by touching heated surface of the heater (stainless plate) (approximately 80°C). Cover the RBH band heater with heat insulator if needed.

7. Troubleshooting

Table 3 shows the possible causes and corrective action.
When you need technical advice, please contact us.

Table 7-1 Fault Diagnosis

Fault	Possible Cause	Corrective Action
A circuit breaker tripping.	Fuse rated lower than it should be.	Refer to Table 1 and choose an adequate fuse.
	Water vapor is condensed on the power connector box and/or inside the power connector.	Disassemble and dry the condensing parts. If it did not solve the problem, please contact us.
The heater temperature does not rise.	Disconnection of the wire.	Disassemble the power connector box or the power connector to find disconnected part. Do not mix the different types of solder when fixing soldered part. If you cannot find any possible cause, please contact us.
	Disconnection of Heater substrate.	It needs replacement. Please contact us.

SERVICE NETWORK

- For technical support, servicing or additional contact information, visit us at www.ulvac-cryo.com.

ULVAC CRYOGENICS INC.

www.ulvac-cryo.com

1222-1 Yabata, Chigasaki, Kanagawa 253-0085, Japan

<Sales>

Tel: +81-467-85-8884

<Service Engineering Division>

Tel: +81-467-85-9366

Fax: +81-467-83-4838

ULVAC CRYOGENICS KOREA INC.

www.ulvac-cryo.co.kr

107, Hyeongoksandan-ro, Cheongbuk-Myeon, Pyeongtaek-si,
Gyeonggi-Do, Korea, 17812

Tel: +82-31-683-2926

Fax: +82-31-683-2956

ULVAC CRYOGENICS (NINGBO) INC.

www.ulvac-cryo.com

No.888 Tonghui Road, Jiangbei District, Ningbo, China, 315020

Tel: +86-574-879-03322

Fax: +86-574-879-10707

This page intentionally left blank.

Revision History

Date	Revision No.	Contents
2006-04-06	2006.04	First edition
2006-12-13	2006DR01	Model U20HSP and U30HP are added and unavailable models are deleted. Correction of error.
2007-09-05	2007SR02	Disposal consideration has been added. (PIW-1)
2009-06-08	2009JE03	“Introduction” has been revised. UCN address has been changed. “SERVICE NETWORK” has revised.
2011-09-21	2011SR04	Full-fledged revision.
2013-11-08	2013NR05	“Introduction” has been revised. “SERVICE NETWORK” has revised.
2014-10-07	2014OR06	Table I RBH-10HL(UFC/ICF) and RBH-22WB have been added. Table II U10HL(UFC/ICF) and U22WB have been added.
2016-05-20	2016MY07	Table I RBH-20HL/BL and RBH-22B and RBH-22BL have been added. Table II U20BL and U20BLM and U22B and U20BL have been added.
2016-10-20	2016OR08	Table II U20P, U20H and U20HSP have been added.
2017-12-08	2017DR09	“SERVICE NETWORK” has been revised.
2019-03-20	2019MH10	2. Specifications Table2-1 has been modified.

This page intentionally left blank