

**SUPER TRAP HEATER  
CONTROLLER  
STC-2A series  
Instruction Manual**

Export Control Policy

We recommend that ALL customers be sure to follow all rules and regulations such as Foreign Exchange and Foreign Trade Law when exporting or reexporting our products.



## Introduction

Thank you for choosing our products. This instruction manual gives information and precautions on handling, installation, operation, and maintenance of the product.

This product is intended for use by qualified personnel who recognize shock hazards and are familiar with the safety precautions required to avoid possible injury. To ensure proper use of this product, read this instruction manual carefully and keep this manual close at hand so that you can use for reference during operation.

If you purchased our other products and/or optional devices with this product, read relevant instruction manuals carefully.

### 1. About the personnel who are involved in handling our products

All personnel involved in handling our products should take a general safety education and training that is officially accepted in the country where our product is used. The personnel are also required to have specialized knowledge/skills and qualification on the electricity, the machinery, the cargo handling, and the vacuum. Especially, the personnel should be familiar with handling a cryopump in order to use it safely. Since we offer a training session (which is subject to fees) as needed for people who use cryopumps for the first time, please do not hesitate to contact our Service Engineering Division to join the training session.

### 2. Warranty

#### 2.1 Gratis warranty period and Warranty coverage

##### 【Gratis warranty period】

Note that an installation period of less than one year after installation in your company or your customer's premises or a period of less than 18 months (counted from the date of production) after shipment from our company, which is shorter, is selected.

##### 【Coverage】

##### (1) Failure diagnosis

As a general rule, diagnosis of failure should be done on site by customer.

However, ULVAC CRYOGENICS or our service network can perform this service for an agreed fee upon the customer's request. There will be no charge if the cause

of the breakdown is found to be a fault of ULVAC CRYOGENICS.

(2) Damage during transportation

When damage by delivery/transportation is admitted, the product will be repaired free of charge within the range of the guarantee expressed in the sales contract.

(3) Breakdown repairs

There will be a charge for breakdown repairs, replacements and on-site visits for the following seven conditions. In those cases the cost shall be your own expense even though the product is within the warranty period.

- ① Breakdowns due to improper storage or handling, careless accident, software or hardware design by the customer.
- ② Breakdowns due to modifications of the product without consent of the manufacturer.
- ③ Breakdowns due to maintenance of the product without authentic parts or breakdowns resulting from using the product outside the specified specifications of the product.
- ④ Breakdowns due to contamination or corrosion caused by user's use conditions.
- ⑤ Breakdowns due to natural disasters (such as fire, earthquake, flood, lightning, salt damage, and so on) , environmental pollution, irregular voltage, and /or usage of undesignated power source.
- ⑥ Breakdowns that are outside the terms of warranty.
- ⑦ Consumables and/or replacement service.

Since the above services are limited to within Japan, diagnosis of failures, etc are not performed abroad. If you desire the after service abroad, please contact ULVAC CRYOGENICS and consult us for details in advance.

## 2.2 Exclusion of opportunity loss from warranty liability

Regardless of the gratis warranty term, compensation to opportunity losses incurred to your company or your customers by failures of ULVAC CRYOGENICS products and compensation for damages to products other than ULVAC CRYOGENICS products and other services are not covered under warranty.

### 2.3 Repair period after production is discontinued

ULVAC CRYOGENICS shall accept product repairs for seven years after production of the product is discontinued.

### 3. Service Form

After the products are delivered, please fill out the following information in the blanks. If you have any questions or technical problems, please feel free to contact the nearest Customer Support Center or headquarters. Please refer to "Service Network".

Cryopump/Super trap Model	:	_____
Cryopump/Super trap Serial No.	:	_____
Refrigerator Model	:	_____
Refrigerator Serial No.	:	_____
Compressor Model	:	_____
Compressor Serial No.	:	_____
Temperature controller/Thermal display Model	:	_____
Temperature controller/Thermal display Serial No.	:	_____
Option Part Model	:	_____
Optional Part Serial No.	:	_____

### 4. Notes for repair and maintenance requests

We may decline your request for the repair or the maintenance of our products if you refuse to give us information about the presence of the hazardous substance and/or contaminant.

Also, please be aware that we do not accept liability for damages by the contaminant, which might be caused during transportation to our office or the nearest customer support center. To avoid such accident, please pay careful attention to packing of the product

### 5. In case of breakdown and accident

When breakdown or accident occurs, we may ask for keeping the product on site as it is or retrieving the product to investigate its cause. Also we may ask for reporting the detailed process and/or the operating condition. When unidentified malfunction was generated, please contact our Service Engineering Division or

the nearest customer support center with reference to the chapter of Service Network. We ask for cooperation about the above.

## 6. General Precautions

- (1) It is strictly prohibited to duplicate, open, and transfer this instruction manual or any of its parts to a third person without written permission from ULVAC CRYOGENICS.
- (2) Information in this document might be revised without a previous notice for the specification change and the improvement of the product.
- (3) If you have any questions or comments on this document, please do not hesitate to contact us. The phone numbers of local customer support centers are listed at the end of this manual.

## Safety Considerations

Our products have been designed to provide extremely safe and dependable operation when properly used. Following safety precautions must be observed during normal operation and when servicing them.

**WARNING**

A warning describes safety hazards or unsafe practices which could result in severe injury or loss of life.

**CAUTION**

A caution describes safety hazards or unsafe practices which could result in personal injury or equipment damage.

**Toxic gas or chemicals used.**

There is a risk of severe injury upon contact.

**Corrosive chemicals used.**

There is a risk of severe injury upon contact.

**Flammable gas used.**

There is a danger of fire or burn injury.

**Explosive gas used.**

There is a risk of fire or explosion.

**Hazardous voltage .**

Electric shock may cause severe injury or loss of life.

**Hot heating part present.**

There is a risk of burn injury.

This page intentionally left blank



---

## TABLE OF CONTENTS

Disposal Considerations.....	IW-1
1. Features and Types.....	1
1.1. Features .....	1
1.2. Models.....	2
2. Specifications .....	3
3. Component Descriptions.....	5
3.1. STC-2A .....	5
3.2. STC-2A (INV 1kW).....	6
4. Connector Specifications and DIP Switch Specifications .....	7
4.1. Connector specifications.....	7
4.2. DIP switch specifications .....	10
5. Accessories and Optional Cables.....	11
6. Installation .....	13
6.1. Installation site .....	13
6.2. Installation .....	13
7. Wiring .....	14
8. Operations.....	20
9. Parameter Setting .....	24
9.1. Parameter setting method .....	24
9.2. Factory default settings.....	25
10. Troubleshooting.....	27

## FIGURES

Figure 1-1	STC-2A series appearance .....	1
Figure 1-2	Model designation of STC-2A series.....	2
Figure 6-1	Panel cut dimensions and STC-2A installation .....	13
Figure 7-1	STC-2A Optional cable wiring .....	17
Figure 7-2	STC-2A (INV 1kW) Optional cable wiring .....	18
Figure 7-3	Wiring for I/F input and output signal .....	19
Figure 8-1	STC-2A series (without refrigerator negative rotation) operation .....	22
Figure 8-2	STC-2A series (with refrigerator negative rotation function) operation .....	23
Appended Figure 1	STC-2A Dimensional drawing .....	29
2	STC-2A(INV 1kW) Dimensional drawing .....	30
3	STC-2A Electric wiring diagram .....	31
4	STC-2A (INV 1kW) Electric wiring diagram .....	32

## TABLES

Table 1-1	STC-2A series models.....	2
Table 3-1	Component descriptions (STC-2A) .....	5
Table 3-2	Component descriptions (STC-2A(INV 1kW)) .....	6
Table 4-1	Connectable plug types and pin descriptions (STC-2A) .....	7
Table 4-2	Connectable plugs and pins (STC-2A(INV 1kW)) .....	8
Table 4-3	Descriptions of I/F connector pins.....	9
Table 4-4	Descriptions of DIP switch.....	10
Table 5-1	STC-2A series accessories .....	11
Table 5-2	Optional cables.....	12
Table 8-1	Operations .....	20
Table 9-1	Factory default parameter settings (Standard setting mode) .....	25
Table 9-2	Factory default parameter settings (Special setting mode) .....	25
Table 9-3	Guideline for relay ON/OFF count.....	26
Table 10-1	Troubleshooting (descriptions of error indications) .....	27
Table 10-2	Troubleshooting (Other) .....	28

## SHIPPING LIST

Our product has been fully inspected before shipment. However, please make sure that there is no shortage of delivered items referring to the table below, no damage by checking the external view of the product, and product name. STC-2A series has product name on its front body. Be sure that the product you received is exact specifications of your order. Please inform us product name and serial number when you inquire us about the product.

Item	Quantity
Super trap heater controller STC-2A series	1
Input power cable (Refer to section 5, table 5-1)	1
Conversion adapter (Refer to section 5, table 5-1) <sup>※1</sup>	1/each
Connector set (Refer to section 5, table 5-1)	1set
Optional cable set (Refer to section 5, table 5-2)	1set
Instruction Manual	1

<sup>※1</sup>This conversion adapter will be provided if refrigerator of super trap is three-phase motor. In this case, the conversion adapter will be shipped with connecting to the main body of STC-2A series.



### Inspection and Adjustment of STC-2A series

Please contact our technical service department when inspection and/or adjustment of STC-2A series are needed. No circuit or any other parts of this product may be changed and/or adjusted in any shape or form in any circumstances. Note that the any inspection, check, adjustment and repair caused by such change and/or adjustment will be only accepted at your expense even if it is within the warranty period.

This page intentionally left blank.

## Disposal Considerations

Disposal of our products must be done in accordance with applicable national and local laws and regulations.

				<b>WARNING</b>
<p>The cryopumps or cryocoolers may contain residue of hazardous substances resulting from actual use. Contact your safety supervisor and follow the instructions to remove such toxic substances before disposing.</p>				

We provide Safety Data Sheet (SDS) of our products upon your request.  
Please contact us if necessary.

This page intentionally left blank.

## 1. Features and Types

### 1.1. Features

Super Trap Heater Controller STC-2A series is a device that measures and displays the surface temperature of 80K Cryopanel through K Thermocouple which is mounted to UCI (ULVAC CRYOGENICS INCORPORATED) CRYO-T Super Trap. Turning refrigerator power of the compressor ON/OFF, STC-2A series can adjust the surface temperature of 80K Cryopanel within a range of preset temperature.

In addition to the features above, connecting with the inner heater for room temperature quick regeneration, STC-2A series can control the heater to keep the surface temperature being a room temperature (290K) during regeneration.

The appearance of STC-2A series is shown in Figure 1-1 below.

STC-2A series has two different models: STC-2A and STC-2A (INV 1kW). Please refer to section 1.2 “Models” for the difference between them.

When you purchased a Super Trap which has the overheat protection sensor for the heater, the sensor can be activated/deactivated by switching the DIP switch of the STC-2A series.



**Figure 1-1 STC-2A series appearance**

**1.2. Models**

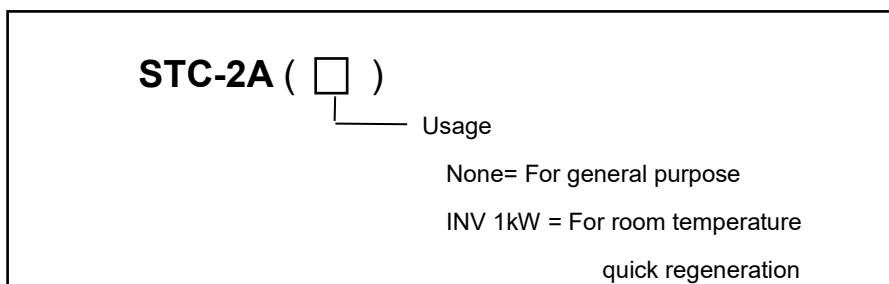

**Figure 1-2 Model designation of STC-2A series**

**Table 1-1 STC-2A series models**

Usage	Types	Refrigerator power control method	Heater capacity
For general purpose	STC-2A	Relay control <sup>※1</sup>	500W
For room temperature quick regeneration	STC-2A (INV 1kW)	Inverter control <sup>※2</sup>	1000W

<sup>※1</sup> Relay control method: The way to control refrigerator power line “ON/OFF” by relay with placing STC-2A series between the compressor and the refrigerator.

<sup>※2</sup> Inverter control method: The way to control “Refrigerator ON Command” with the optional inverter which is installed to the compressor.



**2. Specifications**

- Dimensions.....240mm(W) x 100mm(H) x 300mm(D)  
(See the external dimensions for the details)
- Weight .....Approx.3.2kg
- Power Source.....Single-phase 100VAC±10% 50Hz/60Hz  
Circuit protector capacity : 10A (15A)<sup>\*1</sup>  
Note: including Internal power consumption
- Internal Power Consumption ..... MAX. 80W Note: excluding heater electrical power
- Operation Environment ..... Ambient temperature : from -10°C to 40°C (No freezing)  
Ambient humidity : Below 80%RH (No condensation)  
Altitude : Below 1000m
- Input ..... TC-IN  
K thermocouple input  
REF-IN(INV ON/OFF)<sup>\*1</sup>  
Refrigerator power input : 144 VAC - 240VAC (50 - 80Hz)  
OH-IN  
Sensor for overheat protection : K thermocouple  
(Select use/not use with the DIP switch)  
(Refer to section 4.2)  
SYSTEM I/F  
Photo coupler input (No-voltage contact input) : MAX 4mA
- Output.....HEATER  
No.1 HEATER : 100VAC MAX 5A (10A)<sup>\*1</sup>  
No.2 HEATER : 100VAC MAX 5A (10A)<sup>\*1</sup>  
Total: MAX 5A (10A)  
Note: including internal power consumption  
SYSTEM I/F  
Photo coupler output : MAX 8mA  
REF-OUT  
Relay output three-phase 144VAC - 240VAC MAX2A  
(INV ON/OFF) <sup>\*1</sup>  
24VDC MAX1A

<sup>\*1</sup> ( ) shows STC-2A(INV 1kW)

**TC-OUT**

K thermocouple output (Not isolated from TC-IN.

To use TC-OUT make sure to isolate it from TC-IN. (See section 7))

- Insulation resistance ..... 500VDC 20MΩ or above
- Withstand voltage ..... 1000VAC/1min between power source terminal and earth terminal  
500VAC/1min between I/O (input-output) terminal and earth terminal
- Display ..... 4 digit 7segment display
  - Display range : 45K - 400K
  - Display accuracy : 400K - 123K ±0.5%FS
  - 123K - 73K ±3%FS
  - <73K Out of K thermocouple accuracy range

Note: excluding reference junction compensation accuracy

Reference junction compensation accuracy : ±2.0°C (23°C ± 5°C)

The range that can keep display accuracy : 23 ± 5°C

※1( ) shows STC-2A(INV 1kW)



- Do NOT heat the Super Trap exceeding 70°C(340K). It may damage the Super Trap.
- An alarm will sound from STC-2A series when the indicated temperature has reached 330K. Cut off all power sources right after the alarm activation.

**3. Component Descriptions**

**3.1. STC-2A**

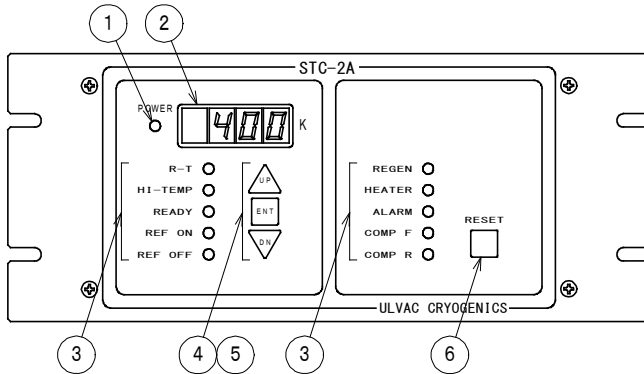

**Table 3-1 Component descriptions (STC-2A)**

	Name	Description	
①	POWER	Lights up when powered ON(100VAC) .	
②	7-segment display	Normal mode	Displays the temperature of super trap panel.
		Parameter setting mode	It displays a set value (See section 9.1).
③	LED Status indicator		
	• R-T	LEDs light up when photo coupler is output to I/F of the connector on the rear.	
	• HI-TEMP	See section 8 (Figure 8-1) for operation and section 9.2 for initial set value.	
	• READY		
	• REF ON	LED lights up when the refrigerator is ON.	
	• REF OFF	LED lights up when the refrigerator is OFF. (Note that the LED will not light up when the compressor unit is stopped.)	
	• REGEN	LED lights up during regeneration (I/F input [REGEN] signal of STC-2A series is ON).	
	• HEATER	LED lights up when the heater is output (I/F input [REGEN] signal of STC-2A series is ON).	
	• ALARM	LED lights up when an alarm is activated. See section 10 "Troubleshooting" for descriptions of error indications.	
	• COMP F	LED lights up when the refrigerator operates in positive rotation. (Normally it is ON)	
• COMP R	LED lights up when the refrigerator operates in negative rotation. (Note that it is only applicable to a model which has "negative rotation" function (Dip SW①:OFF))		
④	[UP]/[DN]	Use for changing parameter value.	
⑤	ENT	Refer to section 9.1 "Parameter setting method" for detail.	
⑥	RESET	Used for releasing alarm.	

### 3.2. STC-2A (INV 1kW)

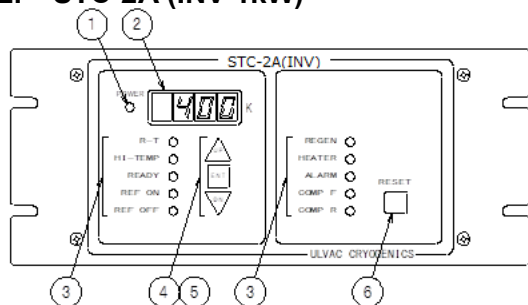

**Table 3-2 Component descriptions (STC-2A(INV 1kW))**

	Name	Description	
①	POWER	Lights up when powered ON(100VAC) .	
②	7-segment display	Normal mode	Displays the temperature of super trap panel.
		Parameter setting mode	It displays a set value (See section 9.1).
③	LED Status indicator		
	• R-T	LEDs light up when photo coupler is output to I/F of the connector on the rear. See section 8 (Figure 8-1) for operation and section 9.2 for factory default settings.	
	• HI-TEMP		
	• READY		
	• REF ON	The response varies depending on the type of the inverter to connect. FR-E720 series: Lights at the temperature that the refrigerator unit is turned ON while the compressor unit is in operation. FR-D720series: Lights at the temperature unit is turned ON while the compressor unit is in normal condition(*1).	
	• REF OFF	The response varies depending on the type of the inverter to connect. FR-E720 series: Lights at the temperature that the refrigerator unit is turned OFF while the compressor unit is in operation. FR-D720series: Lights at the temperature unit is turned OFF while the compressor unit is in normal condition(*1).	
	• REGEN	LED lights up during regeneration (I/F input [REGEN] signal of the STC is ON).	
	• HEATER	LED lights up when the heater is output (I/F input [REGEN] signal of the STC is ON).	
	• ALARM	LED lights up when an alarm is activated. See section 10 "Troubleshooting" for descriptions of error indications.	
	• COMP F	LED lights up when the refrigerator operates in positive rotation. (Normally it is ON)	
• COMP R	LED lights up when the refrigerator operates in negative rotation. (Note that this is only applicable when negative rotation is allowed (Dip SW①:OFF))		
④	[UP]/[DN]	Use these buttons to change parameter values.	
⑤	ENT	Refer to section 9.1 "Parameter setting" for detail.	
⑥	RESET	Use this button to clear the alarm.	

(\*1) "Normal condition" refers to the state that the compressor unit is in operation and both the compressor unit and the inverter have no alarm.

**4. Connector Specifications and DIP Switch Specifications**

**4.1. Connector specifications**

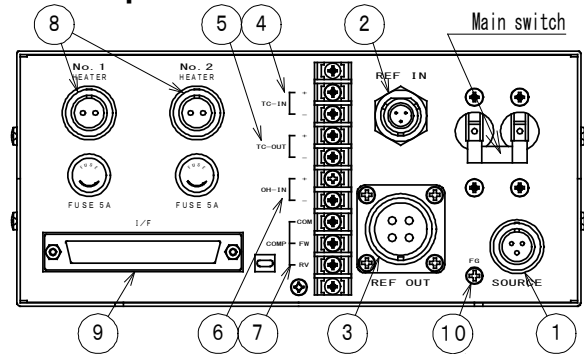

**Table 4-1 Connectable plug types and pin descriptions (STC-2A)**

No.	Name	Type of connectable plug	Pin No.	Description
①	SOURCE	PRC03-12A10-3AF10.5 (TAJIMI)	A	L: Power source input(100V±10%)
			B	N: power source input(100V±10%)
			C	E: Earth
②	REF IN	PT06E-8-3S(424) (Amphenol)	A	R: Refrigerator power source input
			B	S: Refrigerator power source input
			C	T: Refrigerator power source input
			Clamp	E: Earth
③	REF OUT	NCS-254-PM(NANABOSHI)	1	R: Refrigerator power source output
			2	S: Refrigerator power source output
			3	T: Refrigerator power source output
			4	E: Earth
④	TC-IN	Round type crimping terminal $\phi 3$ (Use an M3 terminal of size smaller than 6.2mm)	+	K Thermocouple input (+)
			-	K Thermocouple input (-)
⑤	TC-OUT	Same as above	+	K Thermocouple output (+)
			-	K Thermocouple output (-)
⑥	OH-IN	Same as above	+	K Thermocouple input (+) for overheat protection
			-	K Thermocouple input (-) for overheat protection
⑦	COMP	Same as above	Not in use.	
⑧	HEATER	PRC03-12A10-2AM10.5 (TAJIMI)	A	Each heater output: AC100V MAX5A  (TOTAL MAX5A)
			B	
⑨	I/F	17JE-23370-02(D8B) (DDK)	See table 4-3	
⑩	FG	Round type crimping terminal $\phi 3$ (Use an M3 terminal)	Frame grand	

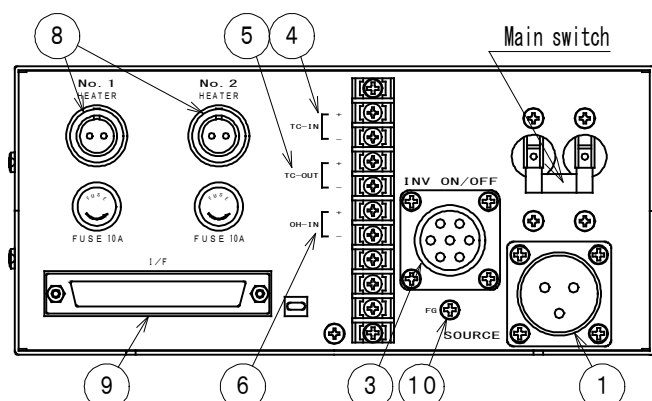

**Table 4-2 Connectable plugs and pins (STC-2A(INV 1kW))**

No.	Name	Type of connectable plug	Pin No.	Description
①	SOURCE	N/MS3106B 16-10S (TAJIMI)	A	L: Power source input(100V±10%)
			B	N: Power source input(100V±10%)
			C	E: Earth
③	INV ON/OFF	NCS-257-P(NANABOSHI)	1	R : COMP Operation signal(200VAC) input
			2	S : COMP Operation signal(200VAC) input
			5	SD: Refrigerator ON signal output COM
			6	STF : Refrigerator positive rotation ON signal output
④	TC-IN	Round type crimping terminal $\phi 3$ (Use an M3 terminal of size smaller than 6.2mm)	+	K Thermocouple input (+)
			-	K Thermocouple input (-)
⑤	TC-OUT	Same as above	+	K Thermocouple output (+)
			-	K Thermocouple output (-)
⑥	OH-IN	Same as above	+	K Thermocouple input (+) for overheat protection
			-	K Thermocouple input (-) for overheat protection
⑧	HEATER	PRC03-12A10-2AM10.5 (TAJIMI)	A	Each heater output: 100VAC MAX10A
			B	(TOTAL MAX10A)
⑨	I/F	17JE-23370-02(D8B) (DDK)	See table 4-3	
⑩	FG	Round type crimping terminal $\phi 3$ (Use an M3 terminal)	Frame grand	

**Table 4-3** Descriptions of I/F connector pins

Signal	Pin No.	Signal Name	Description
Input signal	1	COM	Contact input common (N24)
	2	REGEN	When signal is ON, regeneration operation will be started.
	3-8	N. C.	Keep these connector pins unconnected.
	9	ALARM RESET	It is used to release the condition that keeps alarms activating. After being ON for 0.1 second or more, turn it OFF.
Output signal (open collector)	10	GND_EX	Open collector output common
	11	R-T	It turns to L level when the displayed temperature is above R-T set value (Initial set vale: 290K). *1
	12	READY	It turns to L level when the displayed temperature is below READY set value (Initial set value: 160K). *1 Note that it will not turn to L level unless the temperature is below REF OFF once. (See figure 8-1)
	13	HI-TEMP	It turns to L level when the temperature is above READY set value (Initial set value: 160K). *1
	14	HEATER ON ANS	It turns to L level when the inner heater is ON. *1
	15	ALARM	It turns to L level when an alarm is activated. *1 See Section 10 for varieties of alarm.
	16, 17	N. C.	Keep these connector pins unconnected.
	18	COMP ON	When the temperature is above HI-TEMP1 set value (Initial set value: 310K), It will turn to L level until the temperature is below R-T set value (Initial set value: 290K). *1 It is used in order to prevent the trap from overheating when turning the compressor ON.
	19-27	N. C.	Keep these connector pins unconnected.
	28	GND_EX	Open collector output common
	29	GND_EX	Open collector output common
	30-35	N. C.	Keep these connector pins unconnected.
	36	DC24V_EX	Input 24VDC (P24) for output signal circuit protection.
37	FG	Frame grand	

\*1 L level shows that the transistor for open collector output is ON (conduction state).

H level shows that the transistor for open collector outputs is OFF (non-conduction state).

**4.2. DIP switch specifications**

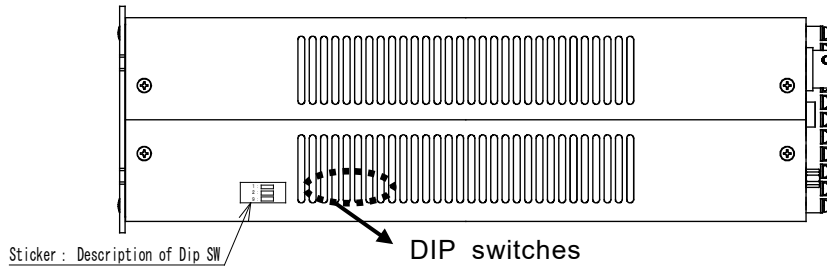

There are two types of MBDI-H1 series DIP switch: Previous Model and New Model.

Previous Model: Push a lever UP to turn ON. The color of the levers is yellow.

(Previous models were sold until April, 2011.)

New Model: Push a lever DOWN to turn ON. The color of the levers is white.

(New model has been sold from May, 2011.)

Example: When No.9 and No.10 are ON.

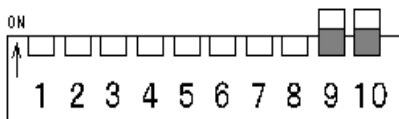

[Previous Model]

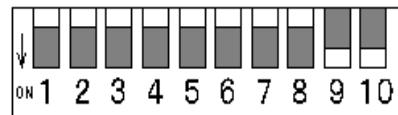

[New Model]

**Table 4-4 Descriptions of DIP switch**

No.	Item	Setting
1	Refrigerator negative rotation	OFF ...with ON ...without
2	STC-P connection	OFF...without ON ...with
3~8	Not in use	OFF
9	Function that prevent HEATER from overheat	OFF ...with ON...without
10	Not in use	OFF



**CAUTION**

DIP switch settings are made before shipment when the specifications of the Super Trap connected to the STC-2A are clear. Do not make unnecessary changes. Please contact us when the settings need to be changed.

The set values are shown on left of the DIP switches if the settings are made by us before shipment.



### 5. Accessories and Optional Cables

Unless purchasing the optional cables in Table 2, the accessories listed in the table below are attached to the STC-2A series. In that case all connections and wiring should be made by customers.

**Table 5-1 STC-2A series accessories**

Item	Type	Appearance	Made by	Usage	Volume
① Power cable	GP-HS03	 3 pins, female	ULVAC CRYOGENICS	STC-2A	1 (3m)
	GP-HS02	 3 pins, female	ULVAC CRYOGENICS	STC-2A (INV/1KW)	
② Connector	PRC03-12A10-2AM10.5	 Male	TAJIMI	STC-2A and STC-2A (INV/1KW)	2
③ Connector	17JE-23370-02(D8B)-CG or Connector: XM3A-3721 Hood: XM2S-3712	 or  37 pins Male Screws:M3x5	DDK or OMRON	STC-2A and STC-2A (INV/1KW)	1
	④ Connector	NCS-257-P	 Female	Nanaboshi	STC-2A (INV/1KW)
⑤ Conversion adapter*1	Refrigerator harness (D type)		ULVAC CRYOGENICS	STC-2A	1/each (30cm)
	Compressor harness (D type)				

(\*1) Adapters that convert 2-phase connectors to 3-phase. The conversion adapters are included with shipment when the Super Traps are equipped with a 3-phase motor type refrigerator.

When purchasing the STC-2A series as a part of super trap system, it is available to specify and order optional cable. Table 5-2 below shows optional cables. Also refer to section 7 for “Wiring”. Note that contents of Accessories in table 5-1 will be changed when optional cable is purchased.

**Table 5-2 Optional cables**

	Name	Type	Appearance	Note
①	Refrigerator power cable	—	For 2 phase 	
		—	For 3phase 	
②	K Thermocouple cable	ST-HS10		
③	Heater cable	ST-HS51 ST-HS52	ST-HS51 : For cartridge heater ST-HS52 : For sheathe heater 	Connector ② in table 5-1 will be excluded from accessory cables when this optional cable is purchased.
④	Inverter control cable	ST-HS60		Connector ④ in table 5-1 will be excluded from accessory cables when this optional cable is purchased.
⑤	K Thermocouple cable for OH	ST-HS11		

When you purchase the STC-2A series as a part of the super trap system, please contact our sales representative on deciding appropriate cables.

## 6. Installation

### 6.1. Installation site

- Install STC-2A series in the site under proper usage environment.



### CAUTION

Avoid using STC-2A series in these places.

- Where flammable gas, corrosive gas, oil mist and particles that can deteriorate electrical insulation are generated, or are abundant.
- Where the temperature is below  $-10^{\circ}\text{C}$  or above  $40^{\circ}\text{C}$ .
- Where the relative humidity is 80%RH or below dew point.
- Where highly intense vibration or impact is generated or transferred.
- Near high voltage power lines or where inductive interference can affect the operation of the product.

### 6.2. Installation

Referring to the dimensions in figure 6-1 and cut the front panel of the cabinet and machine four mounting holes. Insert STC-2A series to the cabinet from the front panel. Make sure that it is inserted further enough and steady. Then fix it with four screws (M4) from the back of the cabinet.

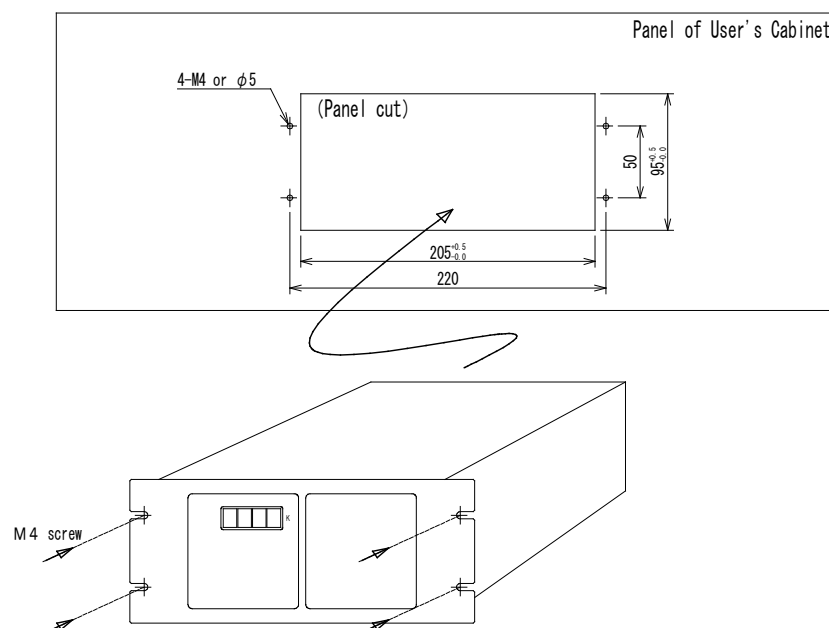

Note that the mounting holes need to be tapped to mount the STC-2A with M4 screws. To mount it with nuts without tapping the holes, the size should be  $\phi 5$ .

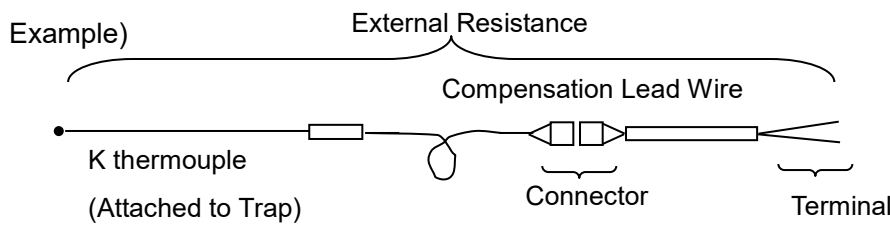
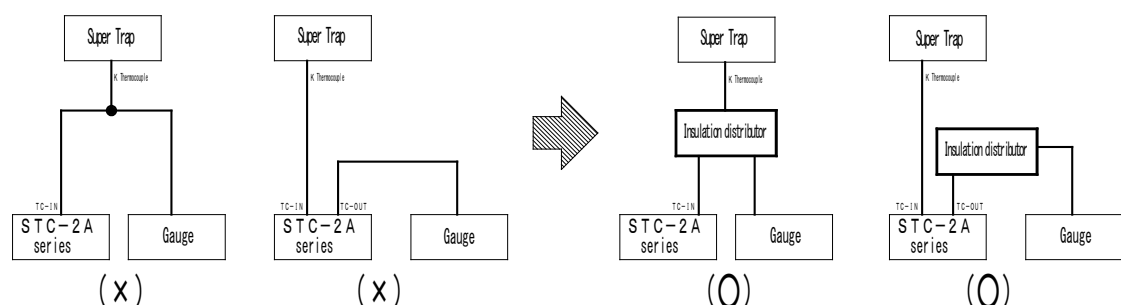

**Figure 6-1** Panel cut dimensions and STC-2A installation

## 7. Wiring

After the installation of STC-2A series, perform wiring work referring to figure 7-1 and 7-3 for STC-2A and figure 7-2 and 7-3 for STC-2A (INV 1kW). Following warnings and cautions must be observed when performing the wiring. Failure to observe these precautions may result in severe bodily injury or loss of life.

	 <b>WARNING</b>
<ul style="list-style-type: none"> <li>● Always disconnect this product from any power source during wiring operation to prevent electrical shock.</li> <li>● Do Not touch the wired terminal and charged devices while supplying power.</li> </ul>	

 <b>CAUTION</b>
<p>● <b>K Thermocouple</b></p> <p>① For K Thermocouple input, use the compensation lead wire with shield which is effective for electric noise.</p> <p>② Total external resistance of K thermocouple input line should be less than 100 Ω .</p> <div style="text-align: center; margin: 10px 0;"> <p>Example)</p>  <p>Total external resistance &lt;math&gt;&lt; 100 \Omega&lt;/math&gt;</p> </div> <p>③ Connecting several gauge for a K Thermocouple in parallel or connecting a gauge to TC-OUT of STC-2A series makes temperature display inaccurate. In such cases, be sure to install an isolator in appropriate place as shown below.</p> <div style="text-align: center; margin: 10px 0;">  </div>



### CAUTION

- Connect the power cable to the AC power source with a protective earth terminal. If you use the extension cord without a protective conductor terminal, protective grounding becomes invalid.
- When connecting the plug type connector to STC-2A series, confirm that it is all the way seated. When unplug the connector, make sure to pull the plug. Do Not pull the cable.
- When connecting a wire to the terminal, use the round crimping terminal with insulating sleeve. If the crimping terminal such as Y shaped crimping terminal is used, the terminal may come off. There is a risk of electrical shock.



### CAUTION

- How to connect the shield wire of the compensating lead wire

When using the compensating lead wire as an extension cable for K thermocouple, either for temperature control or for overheat protection, connect the shield wire of the compensating lead wire to the FG terminal. (Refer to section “4.1. Connector Specifications”)

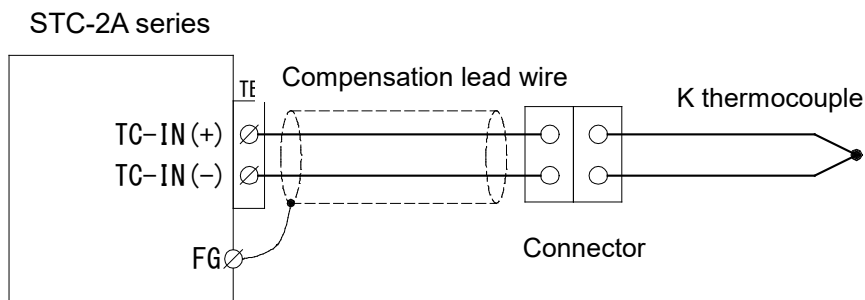

When connecting the K thermocouples to STC-2A series directly without using a compensating lead wire, do not connect the shield wire of the K thermocouples to the FG terminal.

**CAUTION**

For lead-free soldering, be sure to use soldering iron and tip that are lead-free use ONLY. Also, DO NOT mix the lead-free solder with the lead eutectic solder.

It may decrease the lifetime of soldering connection.

It is recommended to indicate the type of soldering for appropriate maintenance.

The character strings listed below are recommended indication for each soldering.

Lead eutectic solder	SnPb	or	SP
Lead-free solder (Sn-Ag)	SnAgCu	or	SAC
Lead-free solder (Sn-Cu)	SnCuNi	or	SCN

**CAUTION****● Conduit Requirements for STC-2A series wiring**

To prevent interference during the operation, there should be a separate conduit for each signal line, control line and AC power line. Especially signal line of Thermocouple input must be in separate conduit from other equipments or AC power lines or control lines for other equipments. Otherwise, STC-2A series operation will be interfered.

If separate conduits cannot be supplied, keep enough distance (generally 300mm or more) between different wirings. It is effective to prevent interference.

**CAUTION**

- After wiring, make sure that wiring has been done correctly. If difference signal has been connected, damage to STC-2A series may result. Also, make sure that the input power is within the allowable range.

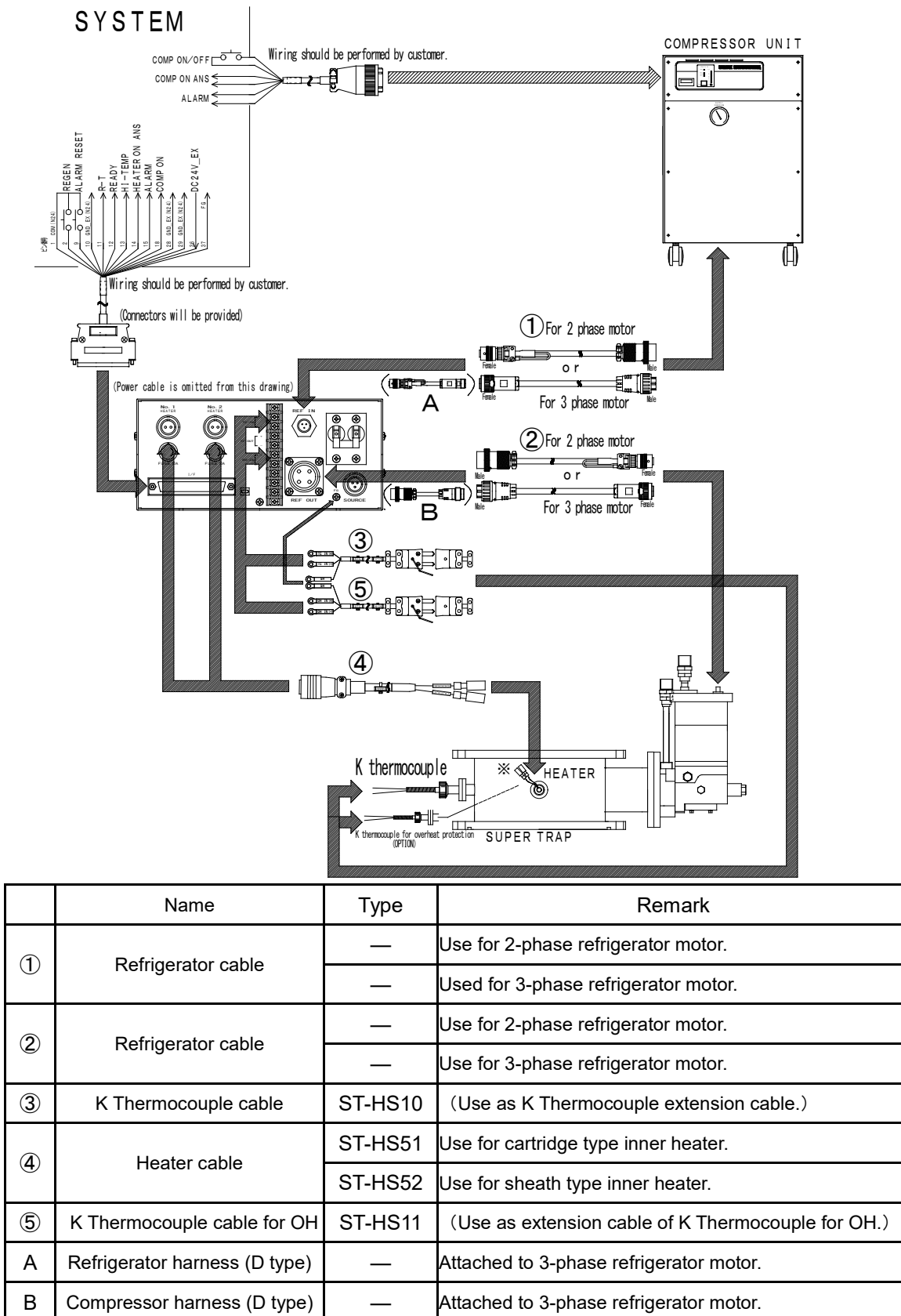
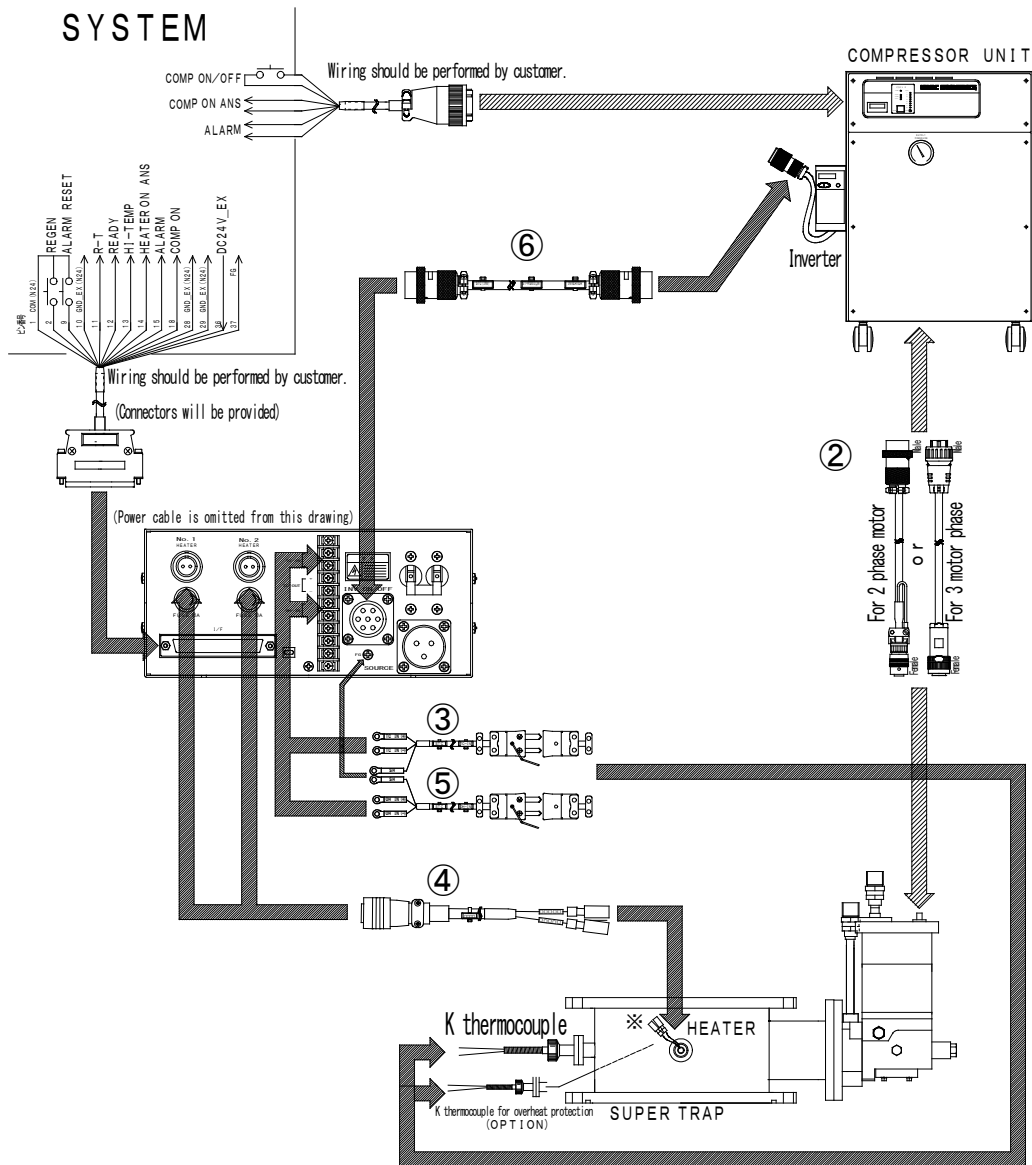

Figure 7-1 STC-2A Optional cable wiring



	Name	Type	Remark
②	Refrigerator cable	—	Use for 2-phase refrigerator motor.
		—	Use for 3-phase refrigerator motor.
③	K Thermocouple cable	ST-HS10	(Use as K Thermocouple extension cable.)
④	Heater cable	ST-HS51	Use for cartridge type inner heater.
		ST-HS52	Use for sheath type inner heater.
⑤	K Thermocouple for OH	ST-HS11	(Use as extension cable of K Thermocouple for OH.)
⑥	Inverter control cable	ST-HS60	

Figure 7-2 STC-2A (INV 1kW) Optional cable wiring



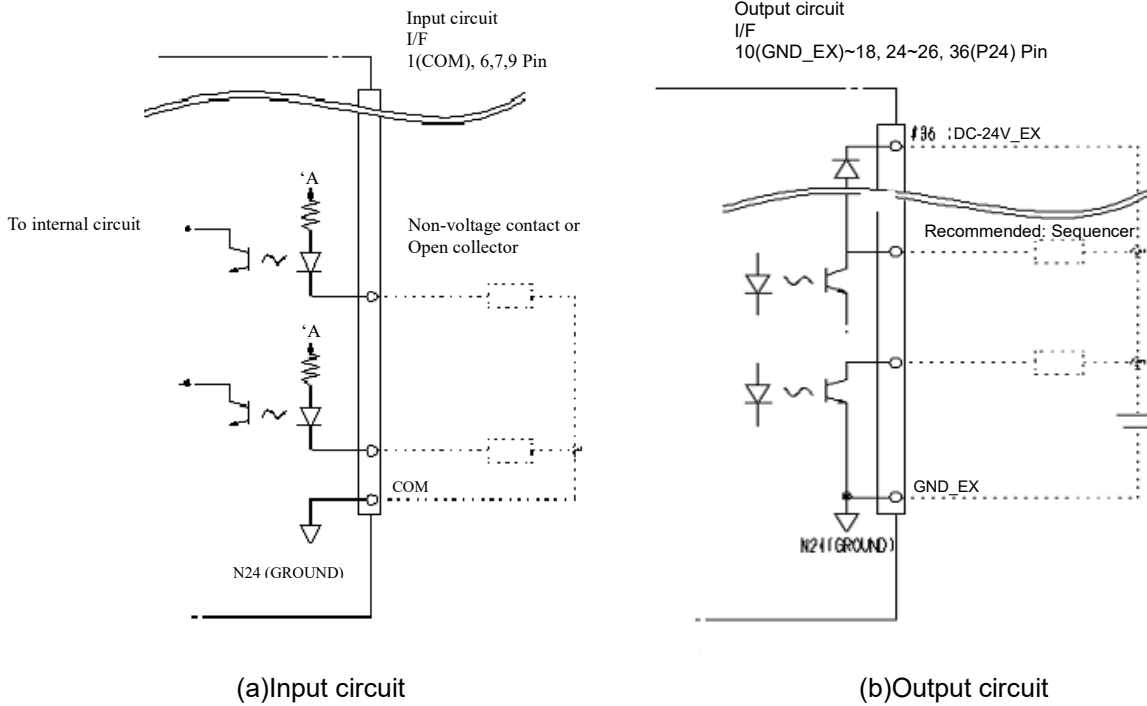

**Figure 7-3 Wiring for I/F input and output signal**

## 8. Operations

**Table 8-1 Operations**

	Step	Operation	Status of STC-2A series
		Turn on the power of STC-2A series.	POWER LED will light up, and then the temperature of the super trap 80K panel will be indicated on 7 segments display.
Cooling operation	①	Start running the compressor unit.	The refrigerator starts operation and keeps operating until READY LED lights up. After READY LED lit up, the temperature will be controlled by the STC-2A within the range between REF OFF set value and REF ON set value. (See figure 8-1)
	②	To finish the operation, stop the compressor unit running.	The refrigerator turns OFF.
Regeneration operation	③	Turn ON I/F input [REGEN] signal of the STC-2A. (Alternate Signal)	Each inner heater of the super trap will be turned ON, and the STC-2A PID control the inner heaters at R-T set value (initial set value: 300K). Only "Refrigerator negative rotation" type will start negative rotation. ( Make sure that the compressor remain operating during refrigerator negative rotation . ) (See figure 8-2)
	④	To finish heater control, turn OFF I/F input [REGEN] signal.	Each inner heater will be turned OFF. HEATER LED will also be OFF.
Standby operation	⑤		When the temperature becomes above HI-TEMP1 set value (Initial set value: 310K), I/F output [COMP ON] signal will be sent until the temperature becomes below R-T set value (Initial set value: 290K). We recommend setting the system to be able to receive the signal and start the compressor operation. It may prevent the super trap from overheating accordingly. (See figure 8-1)



**CAUTION**

During cool down, if the temperature exceeds READY set value (initial set value: 160K) which is the limit temperature that the super trap can maintain its performance, it is recommended to start regeneration.

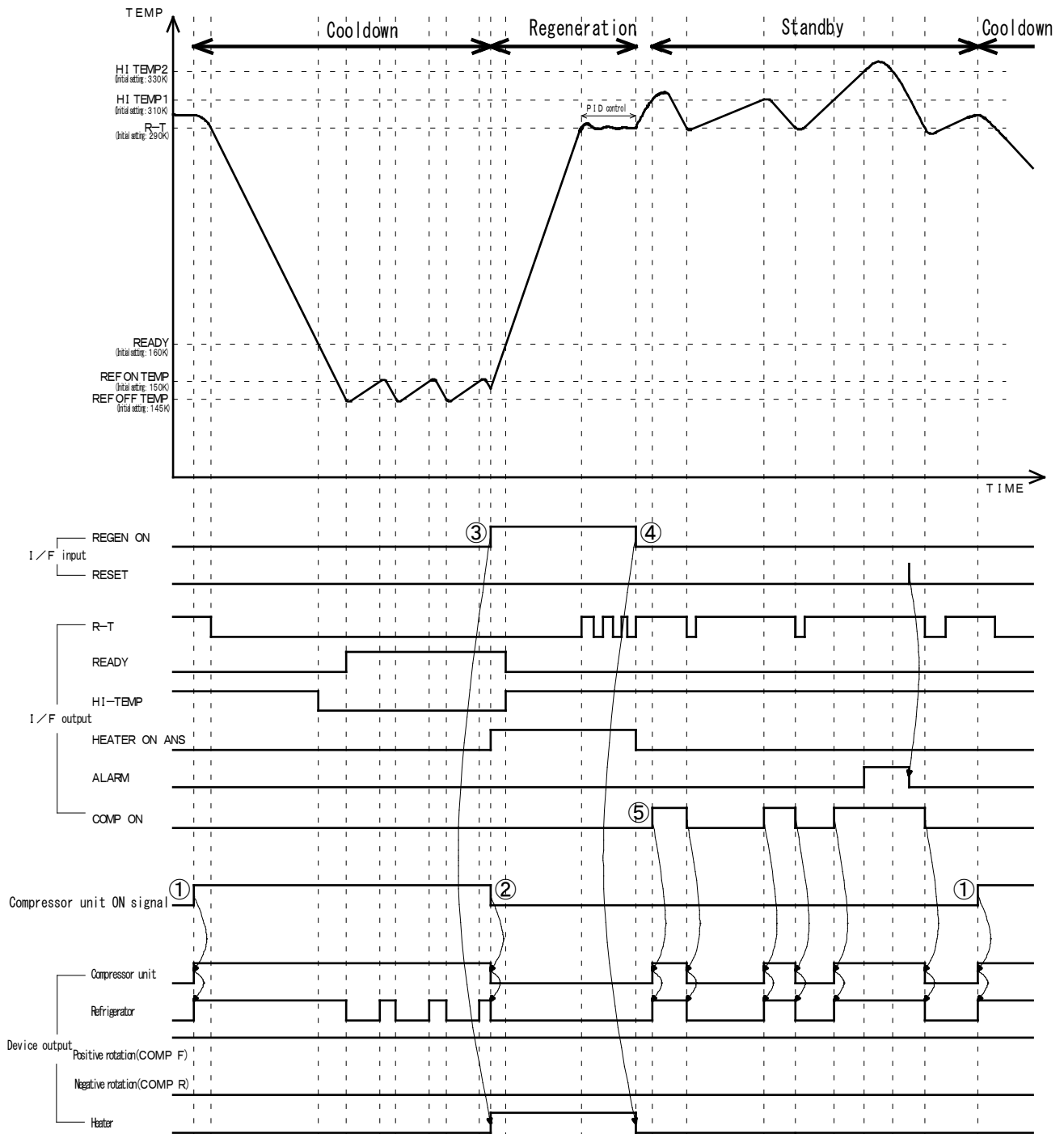

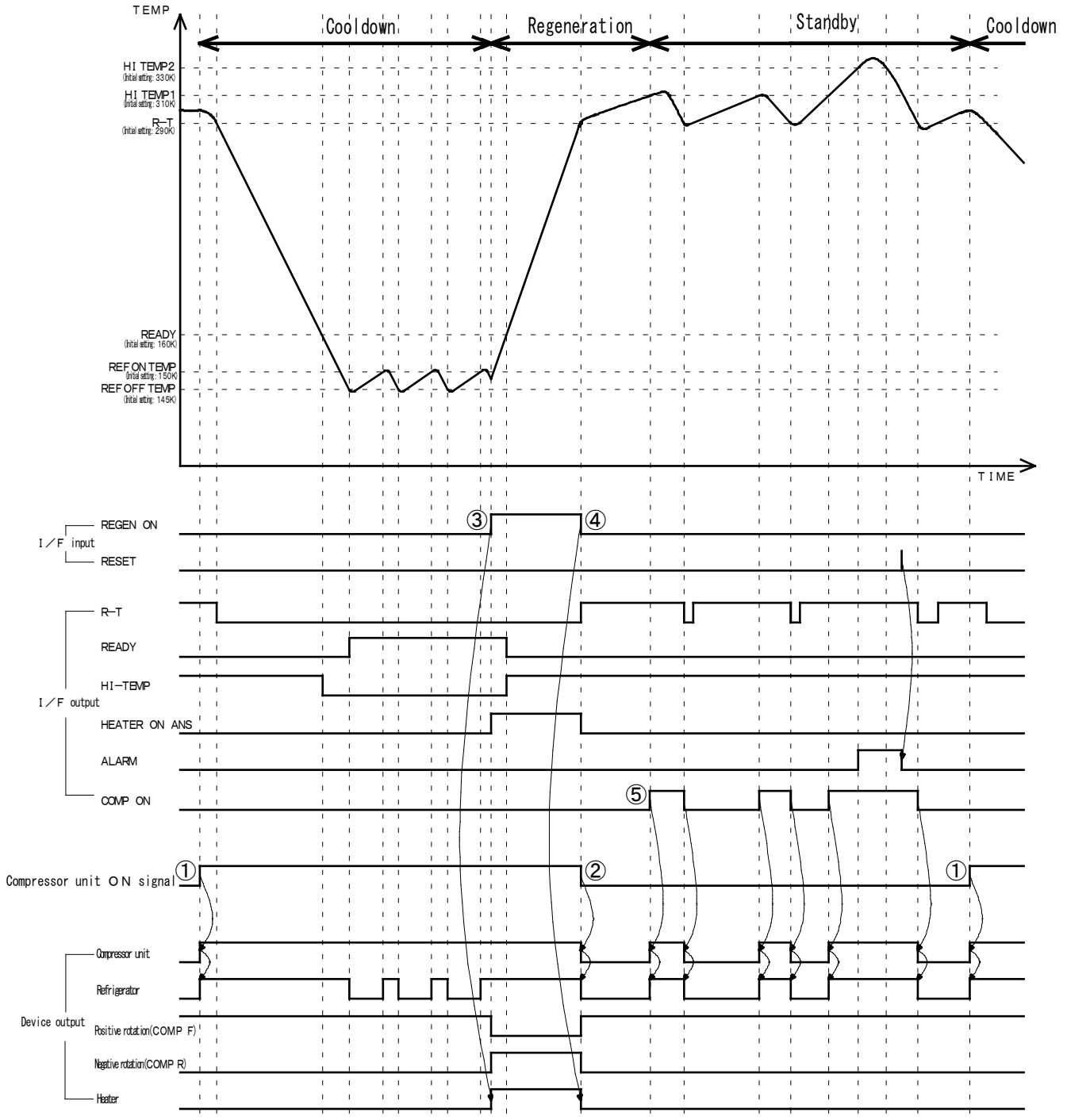

**Figure 8-1** STC-2A series (without refrigerator negative rotation) operation



**Figure 8-2 STC-2A series (with refrigerator negative rotation function) operation**

## 9. Parameter Setting

### 9.1. Parameter setting method

Key	Description
	In parameter setting mode, it is used to increase set value.
	It is used to move to parameter setting mode, and to fix the changed value in the mode.
	In parameter setting mode, it is used to decrease set value.





#### Parameter setting mode

Mode1 : Standard setting mode (See section 9.2 for parameter list.)





Mode2 : Special setting mode (See section 9.2 for parameter list.)

#### ⊙Parameter setting method



##### Mode 1

- ① Press and hold  key for 1 second.
- ② Press  key to select the parameter. (R-T, READY, REF ON, REF OFF)
  - LED : The LED of the selected parameter will flash.
  - Cell : The cell will indicate the parameter.
- ③ Press  or  key to change the set value.
- ④ Press and hold  key until returning to the initial screen to finish the parameter setting mode.
  - R-T → READY → REF ON → REF OFF → Returning to the initial screen



##### Mode 2

- ① Press and hold  key for 2 seconds.
- ② Press  key to select the parameter. (P, I, D, t, 1, 2)
  - Cell : The cell will display the parameter
- ③ Press  or  key to change the set value
- ④ Keep pressing  key until returning to the initial screen to finish the parameter setting mode.
  - P → I → D → t → 1 → 2 → Returning to the initial screen.

#### ⊙Prohibit parameter change (Key operation lock)

Press and hold both  and  keys for 5 seconds to prohibit parameter change.

→ In 7 segments, "on" will be displayed for 2 seconds

Press and hold both  and  keys again for 5 seconds to unlock the keys.

→ In 7 segments, "oFF" will be displayed for 2 seconds

## 9.2. Factory default settings

**Table 9-1 Factory default parameter settings (Standard setting mode)**

Set command	Description	Initial value	Setting range
R-T	ROOM TEMP (Target value of inner heater control). It outputs signal when the temperature is above the set value.	290K	273~300K
READY	The temperature to which the super trap can maintain its performance. During cooling operation, if the temperature exceeds the set value of READY temperature, it is recommended to start regeneration.	160K	45~300K
REF ON	The temperature at which the refrigerator starts running during temperature control.	150K	45~300K
REF OFF	The temperature at which the refrigerator stops running during temperature control.	145K	45~300K

These set values are available to be pre-set before shipment upon your request.

Pre-set values are shown in the sticker “STC-2A Initial set value” which attached on the top surface of STC-2A series body.

**Table 9-2 Factory default parameter settings (Special setting mode)**

Set command	Description	Initial value	Setting range
P	Proportional band of inner heater control	2 K	—
I	Integral time of inner heater control	150 sec	—
D	Derivative time of inner heater control	24 sec	—
t	Energizing time of inner heater ※1	30 min	0~300min
1	The temperature at which stand-by operation (Refrigerator over heart protection operation) starts. (HI-TEMP1)	310 K	—
2	The temperature at which an alarm for refrigerator over heart protection is output (HI-TEMP2)	330 K	—

※ <sup>1</sup>An alarm will be output if the heater is turned on electricity over set value. This set value varies with trap size. If specifications of the trap are obvious before shipment, the set value will be preset at our factory. Set value is shown in the sticker “STC-2A Initial set value” which attached on the top surface of this product.

Notice to the user who purchased STC-2A series as a single item: Inner heater energizing time “t” has been preset as 30min therefore it needs you to change set time “t” in accordance with your trap.



**WARNING**

Do not change the set value of special setting mode. It may result in damage to Super Trap. Note if you need to change energizing time of the inner heater in accordance with usage environment or another reason, please refer to section 9.1 “Parameter setting method”.



**CAUTION**

The temperature control relay endures electrically until its ON/OFF count reaches approximately 300,000. If the temperature control range (the value range between REF ON and REF OFF) is extremely narrow, ON/OFF count of the temperature control relay may exceed 300,000 in several months. Note that this may result in contact welding of the temperature control relay.

**Table 9-3 Guideline for relay ON/OFF count**

Temperature control range	ON/OFF count per hour	Total ON/OFF count when the equipment is continuously operated for one year
10K	Approx. 4/ h	Approx. 35,000/ year
5K	Approx. 12/ h	Approx. 100,000/ year
1K	Approx. 120/ h	Approx. 1 million/ year

The above values are just guidelines. Actual electrical endurance varies depending on thermal load on the equipment. It is recommended to replace the relay before its ON/OFF count reaches 300,000. For relay replacement, please contact our service engineer or CS center near you.



## 10. Troubleshooting

**Table 10-1 Troubleshooting (descriptions of error indications)**

Display	Description	Possible causes	Action
	It outputs due to breaking of heater line.	Inappropriate wiring of heater cable.	Make sure that wiring has been done correctly.
		Blown fuses.	Check the fuses on the rear panel.
		Breaking or damage of the heater.	Change the heater. Contact our customer service.
	It outputs when Heater Energizing Time goes over set time "t" (See section 8.2) .	Disconnecting or improper grounding of K Thermocouple for TC IN, OVERHEAT.	There is a possibility that the refrigerator has been damaged. Contact our customer service.
		The heater is not grounded properly.	There is a possibility that the heater has been damaged. Contact our customer service.
		Energizing time "t" is short concerning to Trap and its usage. ※1	Change Energizing time "t" in accordance with your trap. ※1
	It outputs when the displayed temperature is above HI-TEMP set value (initial set value: 330K).	Interference of heat sources such as heater.	Cut off all heat sources immediately.
		K Thermocouple and its cable line have not been connected.	Connect them correctly with referring to section 7.
		Breaking of K thermocouple	Change K Thermocouple.
	It outputs when the temperature of K Thermocouple for OVERHEAT is above <b>approx.70°C</b> .	Interference of heat sources excepting inner heater.	Cut off all hear sources immediately.
		Miswiring or K Thermocouple for OVERHEAT.	Make sure that wiring has been done correctly.
		Breaking of K Thermocouple for OVERHEAT.	K Thermocouple needs to be changed. Contact our customer service.
		Disconnecting or improper grounding of K Thermocouple for TC IN.	There is a possibility that the refrigerator has been damaged. Contact our customer service.
		Improper grounding of the heater.	Contact our customer service.

※1 Heater Energizing Time varies with conditions of use for your trap.  
Therefore, set value needs to be changed according your device.  
(Conditions of use: quantity of captured water and etc)

**Table 10-2 Troubleshooting (Other)**

Problems	Possible causes	Corrective action
The refrigerator unit does not start running.	Either of Power cable, refrigerator cable, inverter control cable or K Thermocouple cable has not been connected.	Referring to section 7, connect cables correctly.
	Contact failure of the above-mentioned cables	Connect cables correctly.
	Failure of the compressor	Refer to the instruction manual of the compressor.
	Failure of the refrigerator	Refer to the instruction manual of the trap.
	Failure of internal circuit	Please contact us.
The temperature indicator keeps showing "h400" and does not change.	K Thermocouple and its cable line have not been connected.	Connect cable and its line correctly referring to section 7.
	Breaking of K Thermocouple	Change K Thermocouple.
The indicated temperature rises far more than room temperature (around 340K).	"+" and "-" of K Thermocouple have been wired wrong way.	Connect "+" and "-" of K Thermocouple correctly.
	Interference of heat sources such as heater.	Cut off all heat sources immediately.
It is unable to change the parameter. (Out of key operation.)	The function to inhibit the parameters Setting is "on".	Keep pressing [UP] and [DN] keys at the same time for 5 seconds to release the function. (See section 9)
Heater does not work at regeneration.	Power cable has not been connected. Power switch has not been turned on.	Make sure power source has been activated.
	No communication of [REGEN] signal.	Make sure that [REGEN] signal has been communicated.
Regarding failure of compressor unit and refrigerator unit, see the instruction manuals attached with each product.		



**CAUTION**

Maintenance and repair must be made only by qualified maintenance personnel.  
DO NOT remove the cover of the product.

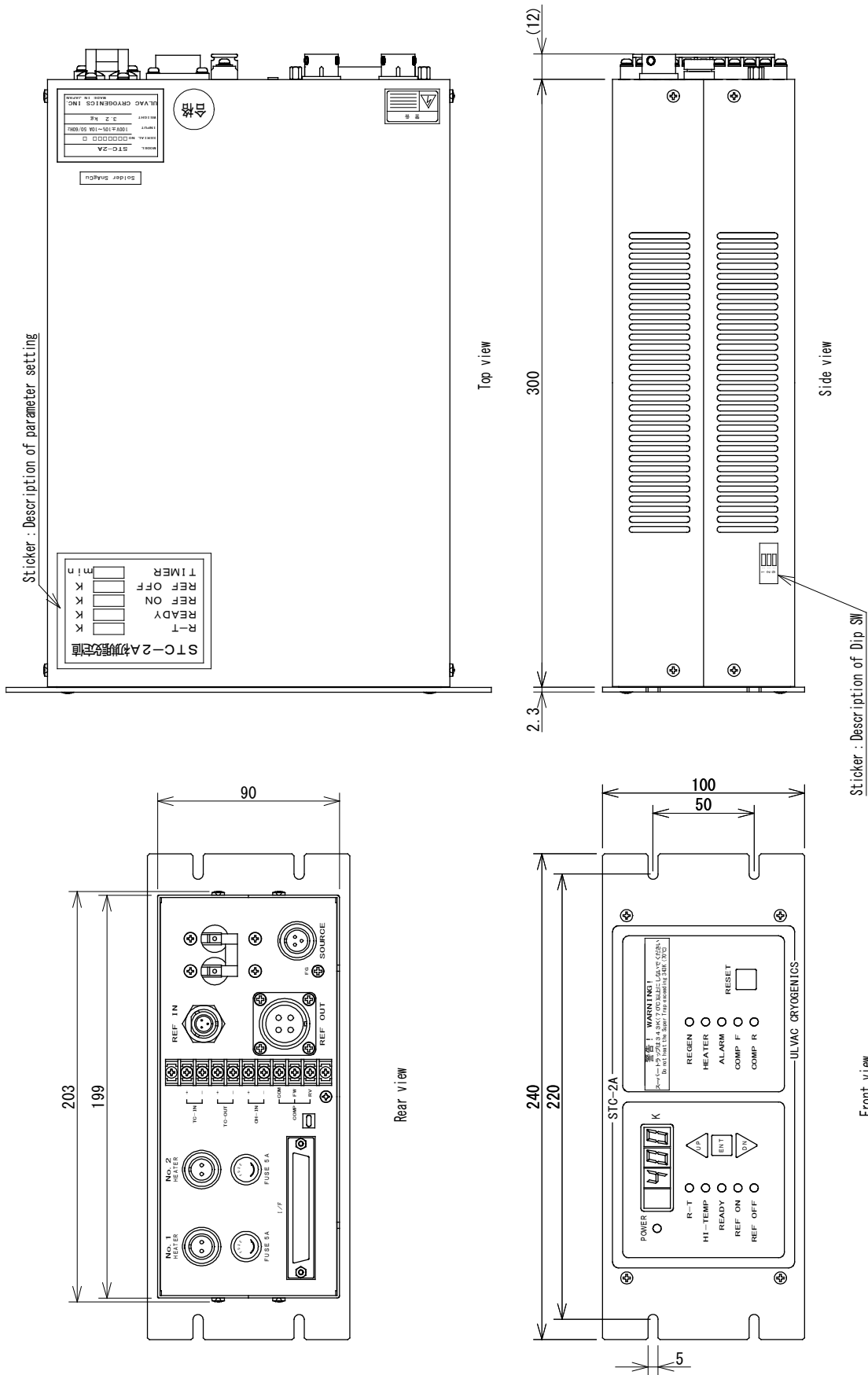

Appended Figure 1 STC-2A Dimensional drawing

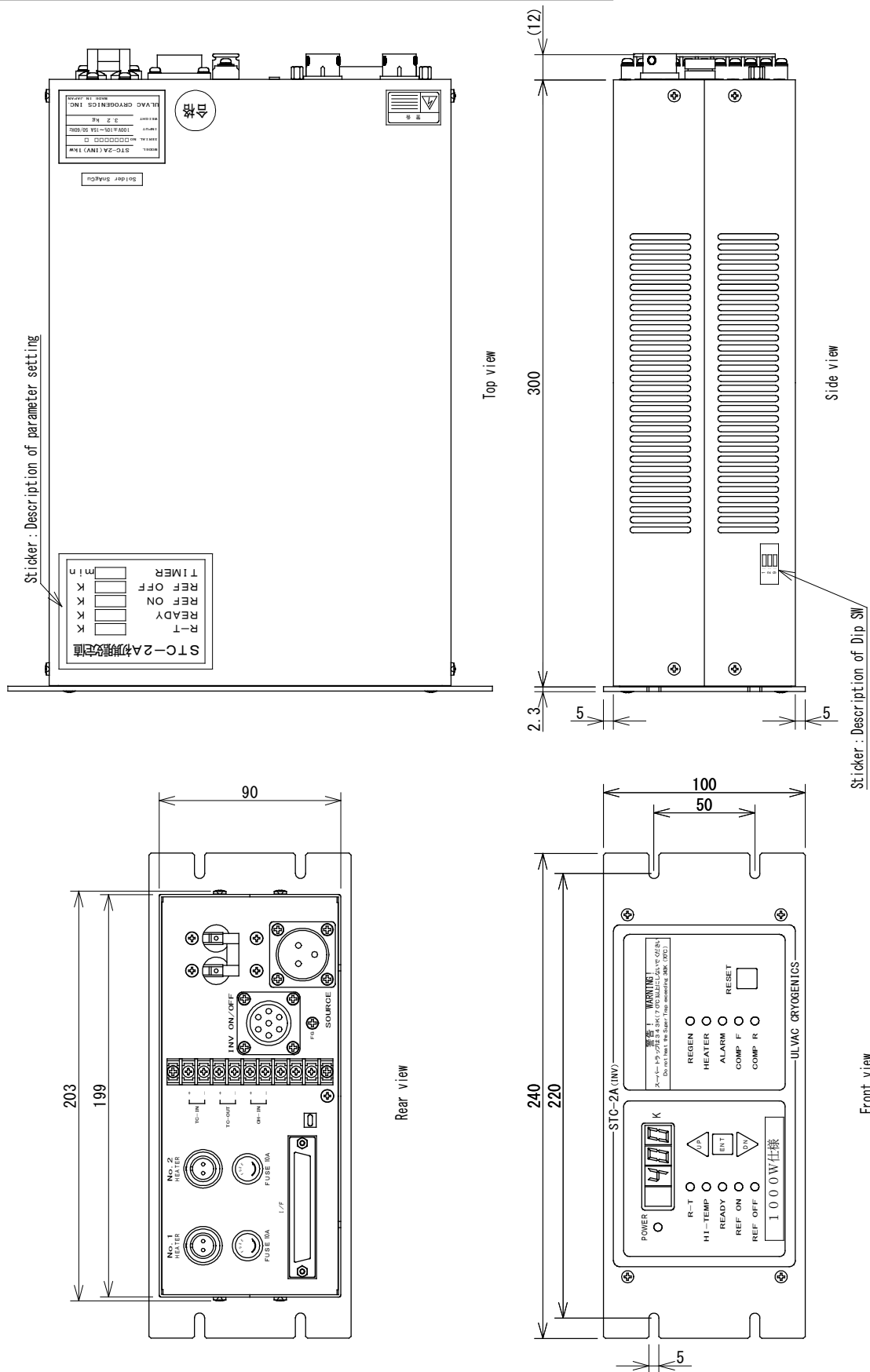

Appended Figure 2 STC-2A (INV 1kW) Dimensional drawing

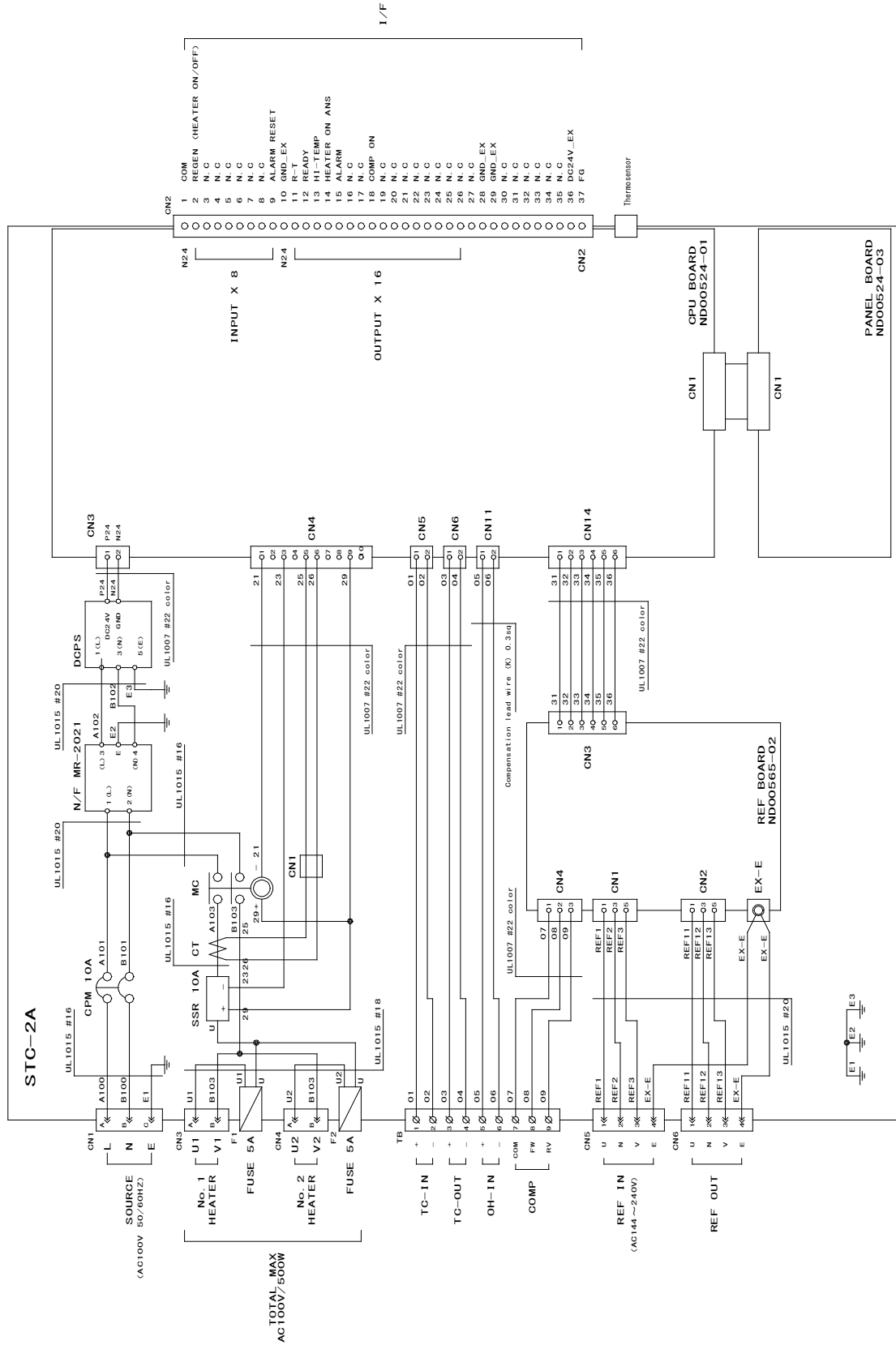

Appended Figure 3 STC-2A Electric wiring diagram

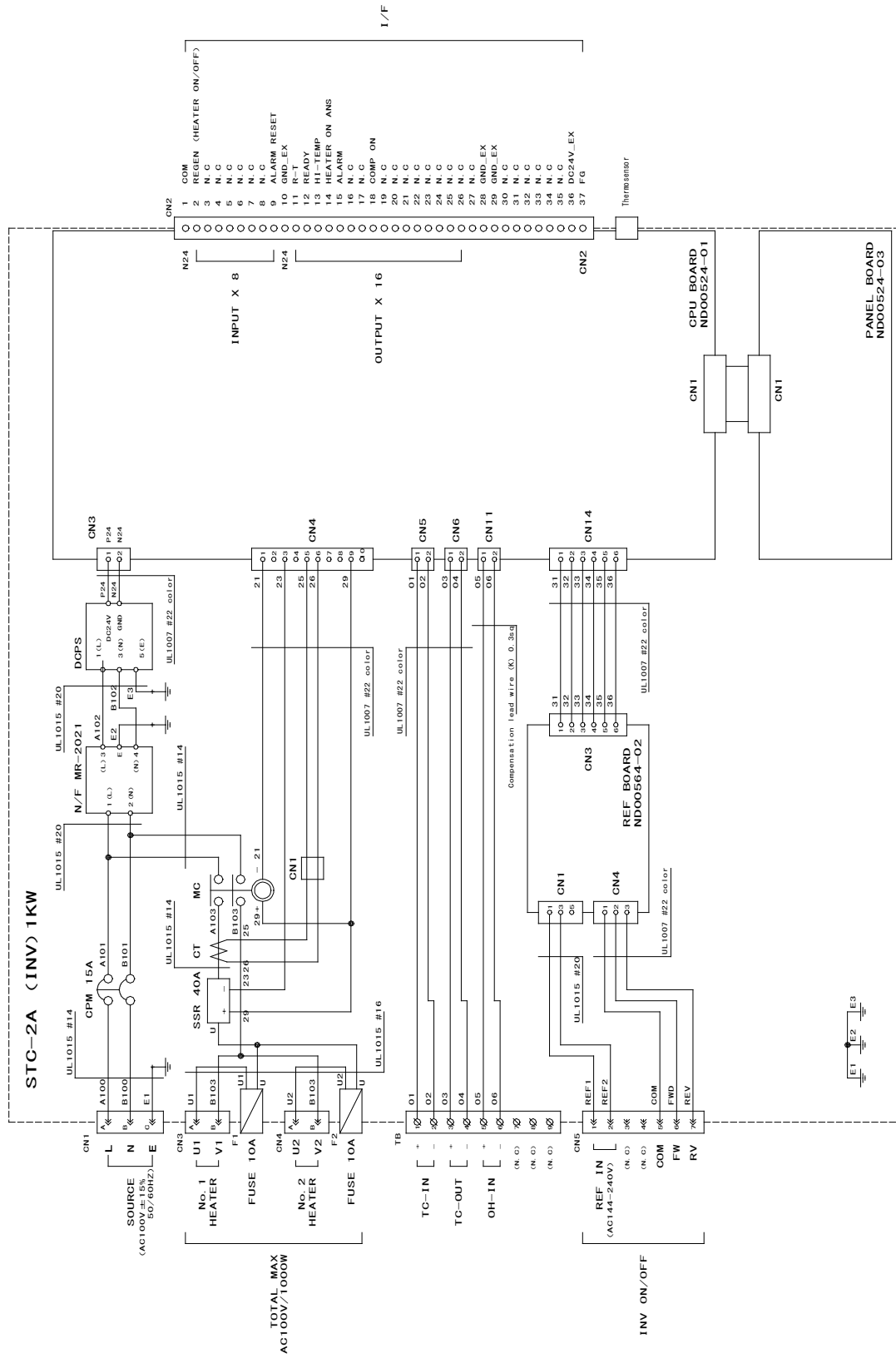

Appended Figure 4 STC-2A(INV 1kW) Electric wiring diagram

---

## SERVICE NETWORK

- For technical support, servicing or additional contact information, visit us at [www.ulvac-cryo.com](http://www.ulvac-cryo.com).

ULVAC CRYOGENICS INC.

[www.ulvac-cryo.com](http://www.ulvac-cryo.com)

1222-1 Yabata, Chigasaki, Kanagawa 253-0085, Japan

<Sales>

Tel: +81-467-85-8884

<Service Engineering Division>

Tel: +81-467-85-9366

Fax: +81-467-83-4838

ULVAC CRYOGENICS KOREA INC.

[www.ulvac-cryo.co.kr](http://www.ulvac-cryo.co.kr)

107, Hyeongoksandan-ro, Cheongbuk-Myeon, Pyeongtaek-si,  
Gyeonggi-Do, Korea, 17812

Tel: +82-31-683-2926

Fax: +82-31-683-2956

ULVAC CRYOGENICS (NINGBO) INC.

[www.ulvac-cryo.com](http://www.ulvac-cryo.com)

No.888 Tonghui Road, Jiangbei District, Ningbo, China, 315020

Tel: +86-574-879-03322

Fax: +86-574-879-10707

This page intentionally left blank.



**Revision History**

Date	Revision No.	Contents
2008-09-11	2008.09	First edition
2009-06-08	2009JE01	“Introduction” has been revised. UCN address has been changed. “SERVICE NETWORK” has been revised.
2009-06-30	2009JE02	Notes have been added.
2012-02-14	2012FY03	Section 4.2 “DIP switch specifications” Descriptions of new type and previous type have been added. The figure of DIP switch has been changed. Table 5-1 “STC-2A series accessories” has been revised. Table 5-2 “Optional cables” figures have been revised. P.14 “●How to connect the shield wire of the compensating lead wire” has been revised. Figure 7-1 and 7-2 “Optional cable wiring” have been revised. Figure 7-3 “Wiring for I/F input and output signal” Output circuit part has been revised. Appended Figure 1 and 2 “Dimensional drawing” Warning label has been revised. “SERVICE NETWORK” has been revised.
2012-06-18	2012JE04	Yokkaichi CS contact information has been changed.
2013-10-09	2013OR05	“Introduction” has been revised. P.26 Table 10-1 “Troubleshooting” has been changed. “SERVICE NETWORK” has been revised.
2013-11-08	2013NR06	“Introduction” has been revised. “SERVICE NETWORK” has been revised.
2018-03-06	2018MH07	“SERVICE NETWORK” has been revised.
2018-03-28	2018MH08	“5. Accessories and Optional Cables” Table 5-1 has been changed.
2022-06-30	2022JE09	“4. Connector Specifications and DIP switch Specifications” Table 4-1 and Table 4-2 have been modified. “5. Accessories and Optional Cables” Table 5-1 has been modified.
2022-12-21	2022DR10	“3. Component Descriptions” Descriptions on STC-2A(INV 1kW) have been added.

---

		<p>“8. Operations” Table 8-1 has been modified.</p>
--	--	---------------------------------------------------------