

## 20K CRYOCOOLER

### Instruction Manual

**RSC50T**

#### Export Control Policy

When applying a refrigerator to a cryocooler for optical sensors, the cryocooler falls under row 6.A.2.d.2 of the control list established by The Wassenaar Arrangement, which is equal to row 10(2) of appended table 1 of Japan's Export Trade Control Order.

Customers must follow all related rules and regulations such as Foreign Exchange and Foreign Trade Act and take appropriate procedures when exporting or re-exporting our refrigerators.



## Introduction

Thank you for choosing our products. This instruction manual gives information and precautions on handling, installation, operation, and maintenance of the product.

This product is intended for use by qualified personnel who recognize shock hazards and are familiar with the safety precautions required to avoid possible injury. To ensure proper use of this product, read this instruction manual carefully and keep this manual close at hand so that you can use for reference during operation.

If you purchased our other products and/or optional devices with this product, read relevant instruction manuals carefully.

### 1. About the personnel who are involved in handling our products

All personnel involved in handling our products should take a general safety education and training that is officially accepted in the country where our product is used. The personnel are also required to have specialized knowledge/skills and qualification on the electricity, the machinery, the cargo handling, and the vacuum. Especially, the personnel should be familiar with handling a cryopump in order to use it safely. Since we offer a training session (which is subject to fees) as needed for people who use cryopumps for the first time, please do not hesitate to contact our Service Engineering Division to join the training session.

### 2. Warranty

#### 2.1 Gratis warranty period and Warranty coverage

##### 【Gratis warranty period】

Note that an installation period of less than one year after installation in your company or your customer's premises or a period of less than 18 months (counted from the date of production) after shipment from our company, which is shorter, is selected.

##### 【Coverage】

##### (1) Failure diagnosis

As a general rule, diagnosis of failure should be done on site by customer.

However, ULVAC CRYOGENICS or our service network can perform this service for an agreed fee upon the customer's request. There will be no charge if the cause

of the breakdown is found to be a fault of ULVAC CRYOGENICS.

(2) Damage during transportation

When damage by delivery/transportation is admitted, the product will be repaired free of charge within the range of the guarantee expressed in the sales contract.

(3) Breakdown repairs

There will be a charge for breakdown repairs, replacements and on-site visits for the following seven conditions. In those cases the cost shall be your own expense even though the product is within the warranty period.

- ① Breakdowns due to improper storage or handling, careless accident, software or hardware design by the customer.
- ② Breakdowns due to modifications of the product without consent of the manufacturer.
- ③ Breakdowns due to maintenance of the product without authentic parts or breakdowns resulting from using the product outside the specified specifications of the product.
- ④ Breakdowns due to contamination or corrosion caused by user's use conditions.
- ⑤ Breakdowns due to natural disasters (such as fire, earthquake, flood, lightning, salt damage, and so on) , environmental pollution, irregular voltage, and /or usage of undesignated power source.
- ⑥ Breakdowns that are outside the terms of warranty.
- ⑦ Consumables and/or replacement service.

Since the above services are limited to within Japan, diagnosis of failures, etc are not performed abroad. If you desire the after service abroad, please contact ULVAC CRYOGENICS and consult us for details in advance.

## 2.2 Exclusion of opportunity loss from warranty liability

Regardless of the gratis warranty term, compensation to opportunity losses incurred to your company or your customers by failures of ULVAC CRYOGENICS products and compensation for damages to products other than ULVAC CRYOGENICS products and other services are not covered under warranty.

### 2.3 Repair period after production is discontinued

ULVAC CRYOGENICS shall accept product repairs for seven years after production of the product is discontinued.

### 3. Service Form

After the products are delivered, please fill out the following information in the blanks. If you have any questions or technical problems, please feel free to contact the nearest Customer Support Center or headquarters. Please refer to "Service Network".

Cryopump/Super trap Model	:	_____
Cryopump/Super trap Serial No.	:	_____
Refrigerator Model	:	_____
Refrigerator Serial No.	:	_____
Compressor Model	:	_____
Compressor Serial No.	:	_____
Temperature controller/Thermal display Model	:	_____
Temperature controller/Thermal display Serial No.	:	_____
Option Part Model	:	_____
Optional Part Serial No.	:	_____

### 4. Notes for repair and maintenance requests

We may decline your request for the repair or the maintenance of our products if you refuse to give us information about the presence of the hazardous substance and/or contaminant.

Also, please be aware that we do not accept liability for damages by the contaminant, which might be caused during transportation to our office or the nearest customer support center. To avoid such accident, please pay careful attention to packing of the product

### 5. In case of breakdown and accident

When breakdown or accident occurs, we may ask for keeping the product on site as it is or retrieving the product to investigate its cause. Also we may ask for reporting the detailed process and/or the operating condition. When unidentified malfunction was generated, please contact our Service Engineering Division or

the nearest customer support center with reference to the chapter of Service Network. We ask for cooperation about the above.

## 6. General Precautions

- (1) It is strictly prohibited to duplicate, open, and transfer this instruction manual or any of its parts to a third person without written permission from ULVAC CRYOGENICS.
- (2) Information in this document might be revised without a previous notice for the specification change and the improvement of the product.
- (3) If you have any questions or comments on this document, please do not hesitate to contact us. The phone numbers of local customer support centers are listed at the end of this manual.

## Safety Considerations

Our products have been designed to provide extremely safe and dependable operation when properly used. Following safety precautions must be observed during normal operation and when servicing them.

**WARNING**

A warning describes safety hazards or unsafe practices which could result in severe injury or loss of life.

**CAUTION**

A caution describes safety hazards or unsafe practices which could result in personal injury or equipment damage.

**Toxic gas or chemicals used.**

There is a risk of severe injury upon contact.

**Corrosive chemicals used.**

There is a risk of severe injury upon contact.

**Flammable gas used.**

There is a danger of fire or burn injury.

**Explosive gas used.**

There is a risk of fire or explosion.

**Hazardous voltage .**

Electric shock may cause severe injury or loss of life.

**Hot heating part present.**

There is a risk of burn injury.

This page intentionally left blank



**TABLE OF CONTENTS**

<b>Safety Instructions</b> .....	<b>S-1</b>
<b>Disposal Consideration</b> .....	<b>IW-1</b>
<b>1. INTRODUCTION</b> .....	<b>1-1</b>
1.1 General.....	1-1
1.2 Specifications .....	1-3
1.3 Vacuum Chamber Specifications .....	1-3
<b>2. INSPECTION</b> .....	<b>2-1</b>
2.1 Shipping Carton Contents .....	2-1
2.2 First Inspection of 20K cryocooler .....	2-1
<b>3. INSTALLATION</b> .....	<b>3-1</b>
3.1 Auxiliary Equipments Required .....	3-1
3.2 Mounting 20K cryocooler to a Vacuum Chamber .....	3-4
3.3 Connecting Roughing Pump .....	3-5
3.4 Connecting Cooling Water Pipe .....	3-5
3.5 Connecting 20K cryocooler to Compressor Unit (Connecting Flexible Hose) .....	3-5
3.6 Connecting Remote Wiring .....	3-6
3.7 Connecting Electrical Cables .....	3-6
<b>4. OPERATION</b> .....	<b>4-1</b>
4.1 Prior to Startup .....	4-1
4.2 Mounting Test Samples .....	4-1
4.3 Rough Pumping .....	4-1
4.4 Startup and Cooldown .....	4-2
4.5 Normal Operation .....	4-2
4.6 Shutdown Procedures .....	4-3
4.7 Handling of Hazardous Materials .....	4-4
<b>5. DISCONNECTION AND STORAGE</b> .....	<b>5-1</b>
5.1 Disconnecting Flexible Hose.....	5-1
5.2 Storage .....	5-2

---

<b>6.</b>	<b>MAINTENANCE.....</b>	<b>6-1</b>
6.1	Scheduled and Unscheduled Maintenance .....	6-1
6.2	Charging Helium Gas.....	6-2
6.3	Helium Circuit Decontamination.....	6-5

**APPENDICES**

<b>A.</b>	<b>Troubleshooting.....</b>	<b>A-1</b>
<b>B.</b>	<b>Flexible Hose .....</b>	<b>B-1</b>
<b>C.</b>	<b>Principles of Refrigerator Operation.....</b>	<b>C-1</b>
<b>D.</b>	<b>Typical Performance Curve .....</b>	<b>D-1</b>
<b>E.</b>	<b>Cooldown Characteristics.....</b>	<b>E-1</b>
<b>F.</b>	<b>Dimensional Drawing .....</b>	<b>F-1</b>

## FIGURES

Figure 1-1	Typical 20K Cryocooler System Configuration .....	1-2
Figure 3-1	Mounting Flange for 20K Cryocooler RSC50T .....	3-3
Figure 3-2	Maintenance space for the 20K Cryocooler.....	3-4
Figure 3-3	Connecting Flexible Hoses .....	3-7
Figure 5-1	Disconnecting Flexible Hose.....	5-1
Figure 6-1	Charging Helium Gas.....	6-3
Figure 6-2	Disconnecting Flexible Hose.....	6-6
Figure 6-3	Connecting Charging Adapter.....	6-6
Figure 6-4	Cryocooler Decontamination Procedures (1).....	6-7
Figure 6-5	Cryocooler Decontamination Procedures (2).....	6-9
Figure 6-6	Connecting Flexible Hoses .....	6-10
Figure C-1	Principle of Refrigeration.....	C-1
Figure C-2	Principle of G-M Cycle Operation.....	C-3
Figure C-3	Single stage Refrigerator .....	C-3

## TABLES

Table 1-1	20K cryocooler System Standard Configuration .....	1-3
Table 1-2	20K cryocooler Standard Capacity (*1).....	1-3
Table 1-3	20K Cryocooler System Standard Specifications.....	1-3
Table 2-1	Shipping Carton Contents of 20K Cryocooler System.....	2-1
Table 6-1	Recommended Maintenance Cycle and Parts .....	6-2
Table A-1	20K Cryocooler Fault Diagnosis.....	A-1
Table A-2	Operating Log.....	A-3

This page intentionally left blank

## Safety Instructions

This chapter describes information necessary for customers to use our cryocoolers safely. Before designing a cryostat and other various equipments utilizing a Cryocooler, or before using the Cryocooler, read this section carefully and be familiar with the content of this section.

**1. Pressure relief valves must be attached to cryogenic equipments including cryostats.**



When using a cryogenic device such as a cryostat, heat transfer of gas is blocked normally by evacuating the surrounding of the cooling section to vacuum. Therefore, the customer needs to prepare a vacuum chamber to surround the cooling section (cylinder) of the Cryocooler.

If a gas is introduced into the vacuum chamber during the operation of the Cryocooler, the gas is condensed and accumulated in the low-temperature section of the Cryocooler. When the Cryocooler is stopped, the gas condensed in the low-temperature section finally returns to the room-temperature gas as the temperature of the Cryocooler increases. Accordingly, the pressure in the vacuum chamber increases. Positive pressure (pressure greater than atmospheric pressure) may be created in the vacuum chamber depending on the volume of the condensed. If it occurs, there is a potential risk of burst and shattering of a vacuum gauge attached on the vacuum chamber and a glass window for observation.

Be sure to attach an appropriate pressure relief valve to the vacuum chamber so that the pressure may be relieved immediately even in case the pressure of the vacuum chamber becomes positive (Figure 1).

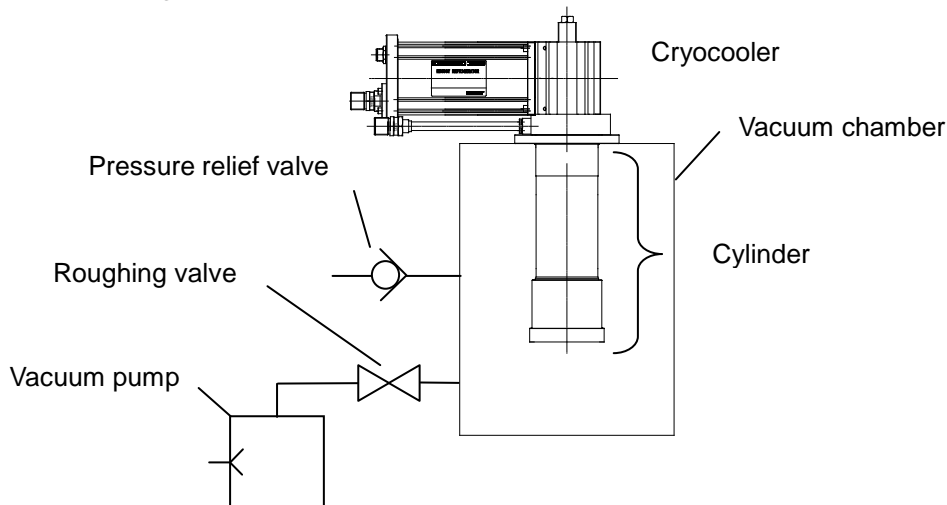

Figure 1 Attaching a pressure relief valve to the vacuum chamber

- ✧ **When a flammable, explosive, combustion enhancing, toxic, or corrosive gas is pumped, connect a dedicated duct on the exhaust side of the pressure relief valve to prevent gas leak from the pressure relief valve to indoor circumference while the operation of the Cryocooler is stopped. (Refer to “5. Stop and warm up cryocooler after pumping flammable, explosive, or combustion enhancing gas.”)**

**2. Check the safety of secondary generated gases in process**



**Some gases would be secondarily generated in vacuum processes. They might contain flammable gas, explosive gas, toxic gas, or combustion enhancing gas.**

For example, water in vacuum chamber, which comes from the atmosphere or the substrate, dissociates into hydrogen and oxygen in plasma. Those gases may be also discharged in large amounts from some evaporants or sputtering targets. **Oxygen is one of the gases which increase the susceptibility to burn, and hydrogen is flammable and explosive.** At atmospheric pressure, the mixed gas of hydrogen of 4% or more and oxygen of 5% or more are sure to cause the explosion momentarily if there is a cause (refer to “3.When flammable or explosive gases pumped”).

In addition, ozone might be secondarily generated when oxygen(O<sub>2</sub>) or carbon dioxide (CO<sub>2</sub>) is resolved in plasma. Ozone is a toxic gas, and moreover the liquid ozone might explode by the reaction with organic substances or any impact when it reaches in a high concentration.

Therefore, it is necessary to confirm the safety of the secondarily generated gas as well as that of process gases.

**For handling flammable or explosive gases**, refer to “3.When pumping flammable or explosive gases”and“4.When pumping oxygen” in this chapter. Implement safety precaution and preventive maintenance as necessary.

**For handling toxic gases**, specific safety measures to the gas may have to be taken as well as the safety precautions for flammable or explosive gases. For example, purge of pump or dilution of exhaust duct with inert gas corresponds to it.

**The customer oneself must execute the appropriate safety measure planning for managing the Cryocooler operation according to an equipment and process where it will be adopted.**

Table 1 Combustion range and detonation range of major gases  
(Volume percentage against air)

Gas		Molecular Weight	Specific Gravity 0°C, 1atm	Boiling Point K	Combustion Range Vol. %	Detonation Range Vol. %
Hydrogen	H <sub>2</sub>	2.016	0.070	20.3	4.0-75.0	18.3- 59
Carbon Monoxide	CO	28.01	0.970	81.7	12.5-74.0	
Hydrogen Sulfide	H <sub>2</sub> S	34.08	1.190	213.6	4.3-45.0	
Silane*	SiH <sub>4</sub>	32.14	1.107	161.2	0.8-98	
Arsine*	AsH <sub>3</sub>	77.94	2.692	210.7	0.8-98	
Phosphine*	PH <sub>3</sub>	34.00	1.146	185.5	1.3-98	
Diborane*	B <sub>2</sub> H <sub>6</sub>	27.67	0.955	180.7	0.8-98	
Ammonium	NH <sub>3</sub>	17.03	0.590	239.8	15-28	
Methane	CH <sub>4</sub>	16.04	0.555	111.6	5.3-14	
Ethane	C <sub>2</sub> H <sub>6</sub>	30.07	1.040	184.6	3.0-12.5	
Propane	C <sub>3</sub> H <sub>8</sub>	44.10	1.550	231.1	2.2-9.5	
Etylene	C <sub>2</sub> H <sub>4</sub>	28.05	0.978	169.5	3.1-32	
Acetylene	C <sub>2</sub> H <sub>2</sub>	26.04	0.907	198.2	2.5-100	4.2- 50

(\*): Hikaru Harada; "Handotai-gas Anzen-ka Souran 1st Edition" (The 1st edition of Semiconductor gas safing comprehensive manual) published by Science Forum Inc. 1984

Except (\*): The high pressure gas safety institute of Japan; "Koatsu-gas Kogyo Gijyutu" (High pressure gas industrial technology) published by Kyoritsu Shuppan Co., Ltd. 1977

Table 2 Combustion range and detonation range of mixture of oxygen and inflammable gas

Gas	Combustion Range (Vol. %)	Detonation Range (Vol. %)
Hydrogen	4 - 94	15 - 90
Acetylene	2.3 - 94.5	3.5 - 93
Methane	5.1 - 61	-
Propane	2.3 - 55	3.7 - 37
Carbon Monoxide	15.5 - 94	38 - 90
Ammonium	15 - 79	25.4 - 75

The high pressure gas safety institute of Japan; "Koatsu-gas Kogyo Gijyutu" (High pressure gas industrial technology) published by Kyoritsu Shuppan Co., Ltd. 1977

### 3. When pumping flammable or explosive gases



- (1). Control and manage the process condition, the time period and method of regeneration in order to keep the concentration of the hazardous gases discharged to the exhaust duct below an allowable value.
- (2). Eliminate ignition factors completely from the vacuum chamber and duct.
- (3). Make sure that the safety precautions mentioned above can work well even in any abnormal events.

Possible causes of ignition in the vacuum chamber are the followings:

- Ignition by a vacuum gauge filament being turned on
- Ignition by a heater with heating element(s) exposed into the process circumstance or the like
- Ignition by static electricity
- Ignition by liquid ozone

If a roughing pipe or exhaust line is made of plastic such as vinyl chloride or etc., it may produce static electricity.

On the other hand, ozone may generate under the process utilizing plasma with oxygen or CO<sub>x</sub> gas. Captured and condensed ozone in the vacuum chamber liquefies in the warm-up process of regeneration. Note here is the following. The liquid ozone is so unstable that it might explode by impact or ignition resulting from the reaction with organic matter.

In case of a pumping flammable or explosive gas(es), appropriate safety precaution must be taken with reference to “5. Stop and warm up Cryocooler after pumping flammable, explosive, or combustion enhancing gas”.



## 4. When pumping oxygen



### **The mixed gas of oxygen and flammable gas should be very dangerous.**

Oxygen is the gas that enhances combustion. Use the Cryocooler after confirming the safety precautions or measures when pumping the mixture of oxygen and flammable gas into the vacuum chamber. In particular, the mixture of oxygen and hydrogen, which has a broad range of combustion/detonation, is extremely dangerous.

The mixed gas with hydrogen of 4% or more and oxygen of 5% or more at atmospheric pressure could cause explosion momentarily (refer to “3. When flammable or explosive gases pumped”).

Therefore, when oxygen is used as a process gas the appropriate safety precautions must be taken with reference to “5. Stop and warm up cryocooler after pumping flammable, explosive, or combustion enhancing gas”.

### **Oxygen may generate ozone.**

**Ozone may be unknowingly generated in plasma production process (e.g., sputtering, etching, glow discharge, EB deposition).**

Captured and solidified ozone in the vacuum chamber liquefies in the warm-up process of regeneration. The liquid ozone at high concentrations might explode by impact or ignition by the reaction with organic matter.

In case that a remarkable amount of ozone is generated in the process and accumulated in the Cryocooler, the following phenomena could be occurred around the Cryocooler at the initial stage of regeneration:

- ① Cracking/popping sounds (as in electrical arcing) occurring within the first few minutes of regeneration.
- ② Gas exhausted from vacuum chamber during regeneration has a pungent odor, similar to that produced in arc welding operation.

**A large volume of ozone can cause an intense explosion and is very dangerous.**

In case of pumping ozone by the Cryocooler, the following safety precautions must be taken.

1. Suppress the amount of captured of ozone in the vacuum chamber below an allowable value by increasing the frequency of regeneration. A required regeneration

cycle depends on the flow rate of oxygen gas and other process conditions.

2. Reduce the flow rate of oxygen gas to the minimum as far as it does not influence the process performance.
3. Reconfirm the safety required if the process condition is changed, as it might increase ozone yield.

When using oxygen as a process gas, appropriate safety precaution and measures must be taken with reference to “5. Stop and warm up Cryocooler after pumping flammable, explosive, or combustion enhancing gas”.

## **5. Shutdown and warm up the cryocooler after pumping flammable, explosive, or combustion enhancing gas**



When stopping and warming up the Cryocooler after pumping flammable, explosive, or combustion enhancing gas, those gases must be safely vaporized again and exhausted. Following safety measures on the method of stop and warm up method are extremely important for operating Cryocooler safely. Please take proper safety precautions and measures from both hardware and process software points of view. Also, recognize there is a risk that some hazardous gas would be secondarily produced in the vacuum chamber as a result of plasma reaction or the like.

### 1. Safety measures for stop and warm up

Following are the safety measures which you should prepare and implement regarding regeneration process after pumping flammable, explosive, or combustion enhancing gas. Please take necessary measures referring to Figure 2. Moreover you may have to take additional safety measures depending on the kind of the gas used, the process conditions, or the environment used.

- ① Both the purge of the cryopump and the dilution of the exhaust duct with inert gas are required to reduce the concentration of flammable gas or explosive gas and keep it under a certain level where the gas does not burn or explode even when it evaporates when the Cryocooler has been stopped or during warm-up time. For inert gas use nitrogen gas that its dew point temperature is  $-40^{\circ}\text{C}$  or below or argon. (In this instruction manual, the terms “inert gas” or “dry nitrogen or argon” mean “nitrogen gas that its dew point temperature is  $-40^{\circ}\text{C}$  or below or argon”.)

Please determine the purge flow rate, the dilution flow rate, and stop and warm up cycle (which depends on the pumping capacity of flammable gas) and take

appropriate safety measures before operation.

- ② Eliminate ignition factor. Insure that there are no sources of ignition (refer to “3. When pumping flammable or explosive gases” in Safety Instruction) on the vacuum chamber side during stop and warm up.
- ③ Be sure to use metallic pipes for the roughing system and exhaust lines in order to prevent generation of static electricity. Ground the pipes with the grounding resistance of 100Ω or lower.

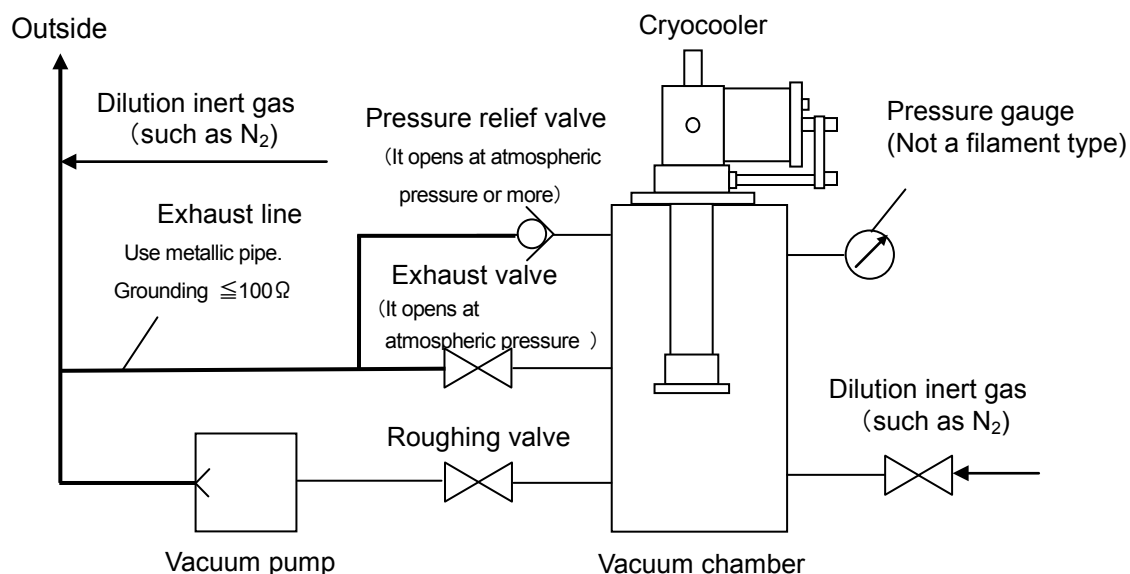

**Figure 2 Dilution of oxygen/inflammable gas**

- ④ In case that the gas to be exhausted is hazardous and lighter than the dilution gas (such as hydrogen gas), design and install the exhaust pipes so that its lighter gas should not be accumulated in the pipes.
- ⑤ Perform inert gas purge into the exhaust line in order to reduce the flammable gas concentration below its combustion range before exhausting them away to atmosphere.
- ⑥ Perform inert gas purge as the stop and warm up start.
- ⑦ Assuming the pressure relief valve would work, connect the pressure relief valve to the exhaust line in order to dilute the gases which might spout out from the valve.
- ⑧ Be sure not to rough pump the vacuum chamber without inspecting the state of the chamber just after power failure. Reduce the concentration of hazardous gases in the chamber and exhaust line by adding inert gas before rough pumping.

It helps to exhaust the vaporized gas safely out of the chamber in case power failure occurred.

- ⑨ When adopting a oil-sealed rotary pump as a roughing pump, change lubricating oils with Fomblin grease which is insensitive to oxygen. Instead, a drypump will be fully recommended.

## 2. Safety measures in emergency

If the Cryocooler is stopped due to an abnormal event such as power failure, water stoppage, or compressed air shutoff, pumped gas evaporates and fills the vacuum chamber as the temperature of the Cryocooler rises. The chamber filled with high concentration of flammable, explosive, or combustion enhancing gas may immediately cause an explosion or high-temperature combustion by any ignition factor (refer to “3. When pumping flammable or explosive gases”). To prevent these hazards, install UPS, and make sure that inert gas purge into the vacuum chamber and dilution in the exhaust duct described in the previous item 1. can be performed even in case of an abnormal event.

### UPS (Uninterruptible Power Supply system) installation

In case that the Cryocooler stops because of blackout etc, hydrogen explosion or high-temperature combustion which may occur if high concentration of O<sub>2</sub> or H<sub>2</sub> is filled up in the chamber with some source(s) of ignition such as O<sub>3</sub>.

UPS is necessary to prevent those hazards.

## 6. When pumping toxic or corrosive gases



Toxic or corrosive gases must be appropriately detoxified or made inert before they are exhausted outdoors from the duct. Ask the safety manager for appropriate instructions.

## 7. Rupture of cylinder by corrosion



The cylinder of Cryocooler is mainly made of stainless steel and copper.

**Special precautions must be taken when pumping corrosive gas which may be produced by plasma reaction, sputtering, etc. in chamber, and corrodes cylinder materials.**

For maximizing performance of the Cryocooler, the stainless steel cylinder thickness is very thin. During normal operation, the pressure of helium gas in the Cryocooler is approximately 2 - 2.5 MPaG and if the corrosion develops, the cylinder may rupture at weak portion.

- ✧ If the Cryocooler is used to pump corrosive gases, periodic pressure proof test is recommended.
- ✧ ULVAC CRYOGENICS INC. executes the pressure proof test of the cylinder by increasing the gas pressure to 1.5 times as high as the operating pressure.

## 8. Assembly and disassembly of a cryocooler



The cryocooler contains high-pressure and high-pure helium gas. When disassembling your refrigerator, please contact our Service Engineering Division or the nearest customer support center first for technical assistance.

If you will perform maintenance or disassembly of the refrigerator by yourself, take the following special precautions for maintenance or disassembly of the refrigerator.

1. Exhaust the helium gas completely from self-sealing couplings on both helium return and supply flexible hoses by using the charging adapter.
2. Make sure that the helium gas pressure has fallen on 0 MPaG and then loosen the bolts.

**NOTE: Do not loosen the fixed components such as bolts, plugs, and pressure relief valve pointed by arrows in Figure 3 before discharging the helium gas. Ignoring this note may cause severe injury or equipment damage by bursted components due to residual pressure.**

Take the following cautions when assembling the refrigerator by yourself.

1. Tighten the bolts of each part in the diagonal sequentially.
2. As the heavy load of the high-pressure helium gas is applied to the cylinder bolts (M6 x 6 ), it is important to tighten them properly. The required torque is 11.6N·m (118kgf·cm).
3. Fill the refrigerator with the helium gas slowly confirming that there is no defect or abnormality.
4. When adding the helium gas, please follow the instructions described in “8.4 Cryopump Decontamination Procedures” in this manual.

**Ensure that the bolts are securely tightened. If the bolts are too loose or are not fastened at appropriate torque, the bolts are damaged and it may lead to accidents.**

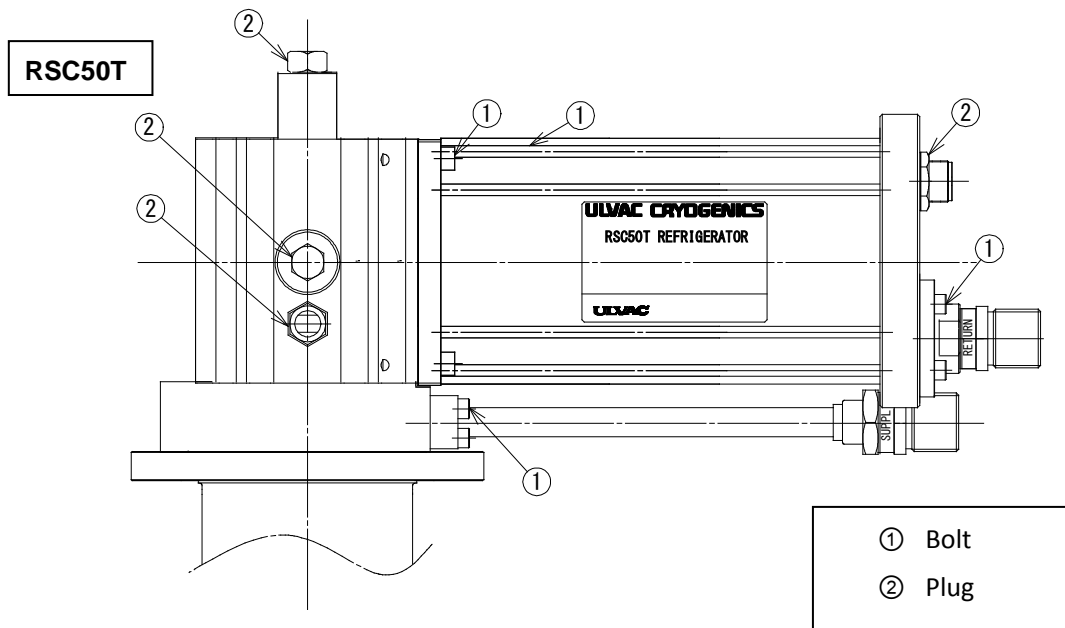

Figure 3 Bolt locations

## 9. Maintenance



Some inner parts of a cryocooler needs replacement at regular intervals (see Section 6 Maintenance). ULVAC CRYOGENICS will perform such maintenance work of RSC50T. Please contact our Service Engineering Division or your nearest Customer Service center and send your RSC50T to us.

## 10. Do not charge the system with excessive helium gas



In our Cryocoolers, high-pressure helium gas is circulated in the system to get an effective refrigerating cycle. Charging with helium gas more than the specified value does not enhance the performance of Cryocooler. Conversely, if the helium gas pressure exceeds the specified value, the pressure relief valve could be open, and it would bring about the trouble of air leakage because particles would stick to the vacuum seal in the valve. Moreover, the excessive high-pressure gas might cause another trouble that the system would stop by hitting the high-pressure switch in the compressor unit.

**Do not charge the Cryocooler with helium gas exceeding the regulated value.**

## 11. Power source of Cryocooler system



Refer to the instruction manual of compressor unit for required power source.

- ① Grounding conductor (earth wire) must be connected (D-class grounding with the ground resistance of 100  $\Omega$  or less.).
- ② Install a ground-fault interrupter at power supply of the compressor unit.
- ③ Do not connect other equipment to the same ground-fault interrupter for the Cryocooler system.

This page intentionally left blank.



## Disposal Considerations

Disposal of our products must be done in accordance with applicable national and local laws and regulations.

				<b>WARNING</b>
<p>The cryopumps or cryocoolers may contain residue of hazardous substances resulting from actual use. Contact your safety supervisor and follow the instructions to remove such toxic substances before disposing.</p>				

We provide Safety Data Sheet (SDS) of our products upon your request.  
Please contact us if necessary.

This page intentionally left blank.

## 1. INTRODUCTION

1.1	General .....	1-1
1.2	Specifications.....	1-3
1.3	Vacuum Chamber Specifications .....	1-3

### 1.1 General

The cryocooler system with a 20K cryocooler provides stable cryogenic temperature around 20K continuously for long hours. The 20K cryocooler system (see Figure 1-1) consists of a 20K cryocooler, compressor unit, flexible hoses, and various cables and uses helium gas as a refrigerant.

The 20K cryocooler system is designed to be used in many areas that require cryogenic temperature. Using this system as a source of cryogenic cooling will make a significant improvement to the restricted designs of equipments where cryogen such as liquid nitrogen is used.

The 20K cryocooler system is used for wide variety of purposes including cooling superconducting coil or superconducting motor, and wind power generation motor etc., and its range of application is further expanding.

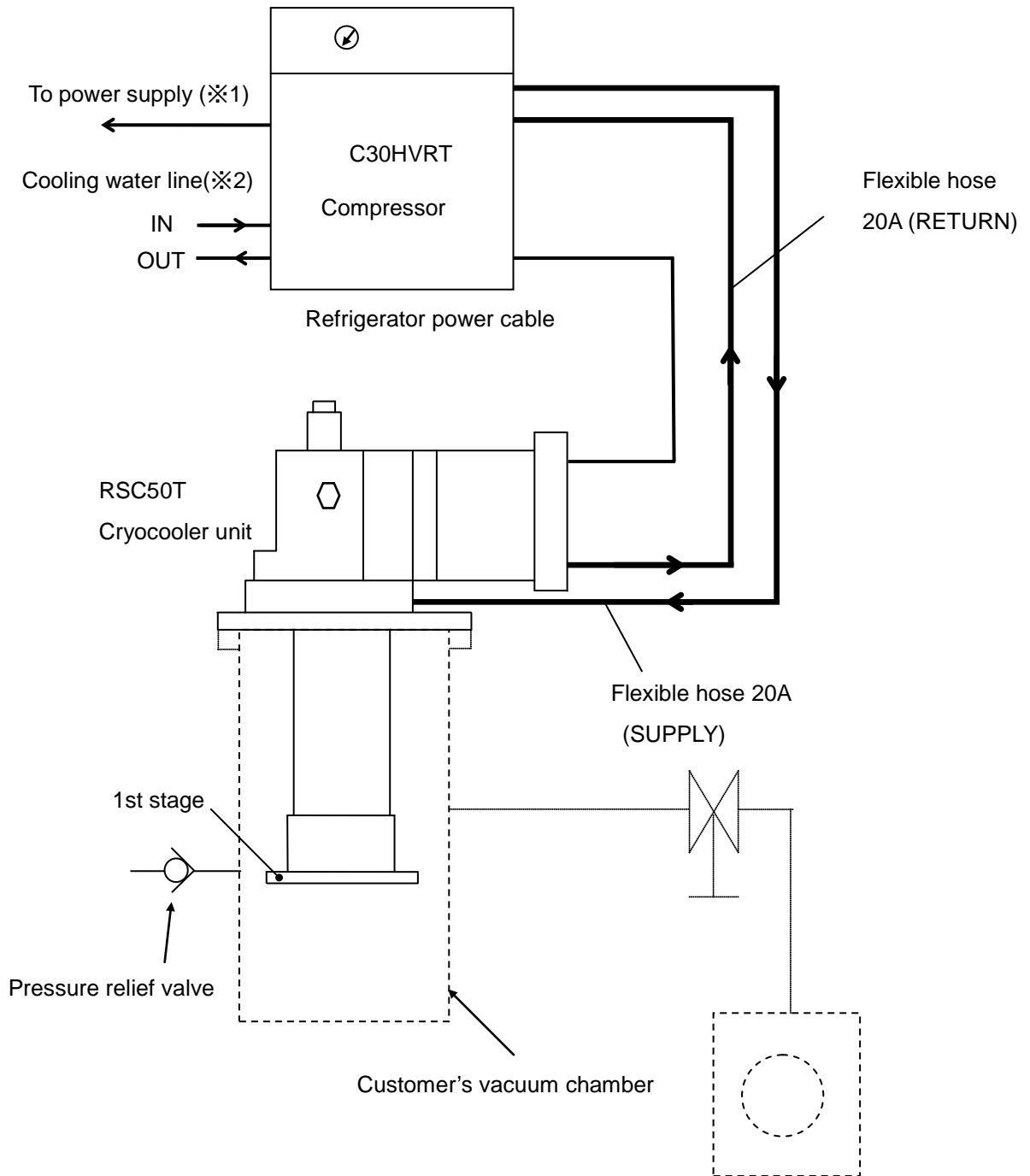

(\*1) Refer to "Compressor Unit Instruction Manual" for specifications of power supply.

(\*2) Refer to "Compressor Unit Instruction Manual" for cooling water requirements.

**Figure 1-1 Typical 20K Cryocooler System Configuration**

## 1.2 Specifications

**Table 1-1 20K cryocooler System Standard Configuration**

20K cryocooler model	Compressor unit (*1) model	Power source	Cooling system
RSC50T	C30HVRT	AC200V × 3 φ	Water-cooled type

(\*1) Refer to compressor instruction manual for more details.

**Table 1-2 20K cryocooler Standard Capacity (\*1)**

Frequency	Cooldown time	Ultimate temperature	Refrigeration Capacity at 20K
50Hz	50min@20K	13K	40W
60Hz	40min@20K		45W

(\*1) The standard configuration of RSC50T cryocooler refrigeration system includes C30HVRT as compressor unit, and installed in a vertical orientation with the first stage pointing down.

**Table 1-3 20K Cryocooler System Standard Specifications**

20K cryocooler	RSC50T
Refrigeration cycle	G-M cycle
Helium gas supply and return connectors	1/2B self-sealing couplings
Dimensions	Refer to Appendix F
Weight	23kg

## 1.3 Vacuum Chamber Specifications

When the 20K cryocooler is used in the cryogenic range, it must be installed to the vacuum chamber to prevent heat load due to thermal conduction and condensation.

Vacuum chamber made of stainless or nickel-plated iron, specular finished inner surface is recommended. Make sure that there is no leakage.

It is recommended that a pressure relief valve is attached to the vacuum chamber to vent gases trapped inside vacuum system in case that the inner pressure exceeds atmospheric pressure.

This page intentionally left blank.

## 2. INSPECTION

2.1 Shipping Carton Contents .....	2-1
2.2 First Inspection of 20K cryocooler .....	2-1

### 2.1 Shipping Carton Contents

When the products are delivered, first inspect the exterior of the shipping carton for visible signs of damage. After removing the shipping carton, make sure that there is no damage or shortage of delivered items. Refer to Table 2-1 for the items included in the 20K cryocooler system. Please refer to the shipping list attached to the system for further details.

**Table 2-1 Shipping Carton Contents of 20K Cryocooler System**

Package	Package quantity	Item	Quantity
(1)	1	20K cryocooler (RSC50T)	1
(2)	1	Compressor unit (C30HVRT)	1
(3)	1	Accessory of compressor unit <sup>(*)</sup>	1 set
		This instruction manual	1
		Instruction manual of compressor unit (C30HVRT instruction manual)	1

<sup>(\*)</sup> Compressor (C30HVRT) power cable, refrigerator (RSC50T) power cable, 20A flexible hoses 20m x 2, and remote connector are included.

### 2.2 First Inspection of 20K cryocooler

Remove the package of the 20K cryocooler and confirm there is neither damage nor a dent in exterior, connector, and cold head of the 20K cryocooler unit, and make sure that all items are delivered.

If you find any missing items or damages of the product, please contact our Service Engineering Division or the nearest Customer Support Center.

This page intentionally left blank.



## 3. INSTALLATION

3.1	Auxiliary Equipments Required .....	3-1
3.2	Mounting 20K cryocooler to a Vacuum Chamber.....	3-4
3.3	Connecting Roughing Pump.....	3-5
3.4	Connecting Cooling Water Pipe.....	3-5
3.5	Connecting 20K cryocooler to Compressor Unit (Connecting Flexible Hose) .....	3-5
3.6	Connecting Remote Wiring .....	3-6
3.7	Connecting Electrical Cables .....	3-6

### 3.1 Auxiliary Equipments Required

For operating 20K cryocooler system, the following auxiliary equipments are required.

- ◆ Vacuum Chamber: It is recommended to supply a stainless-steel (or nickel plated iron) vacuum chamber that has mirror finish inner surface. To use a 20K cryocooler in a temperature range of 20K or lower at the 1st stage, it is necessary that the vacuum chamber maintains vacuum of  $1 \times 10^{-2}$  Pa or lower.

When the stages are warmed back to room temperature, inner pressure of the vacuum chamber may exceed atmospheric pressure. Therefore a vacuum chamber must have a pressure relief valve that is activated at the inner pressure of 10 - 20kPaG.

Refer to Figure 3-1 for the dimensions of recommended vacuum chamber flanges to mount a 20K cryocooler (for O-ring type).

- ◆ Roughing pump : Used for rough pump the vacuum chamber.  
To minimize heat transfer via gases, the roughing pump is required to be able to achieve 1Pa or lower.
- ◆ Roughing valve : Used to isolate the vacuum chamber from the roughing pump.
- ◆ Vacuum gauge for rough pumping : Used to measure the pressure during rough pumping.  
The measurement range must be from atmospheric pressure to 1Pa.
- ◆ High-vacuum pump : Used on an as-needed basis, such as when a large volume of outgas is emitted. A recommended pump is of oil-back-diffusion-free type, such as a turbo molecular pump.
- ◆ High-vacuum valve : Required for switching to the high-vacuum pump.
- ◆ Vacuum gauge for high-vacuum pumping : Used to measure the vacuum chamber pressure during 20K cryocooler system operation.  
Ionization gauge is recommended. Measurement range :  $10^{-1}$  -  $10^{-6}$ Pa
- ◆ Temperature sensor, Temperature display : Used to monitor the temperature of 20K cryocooler. Use sensors or indicators of necessary specifications.

20K Cryocooler RSC50T  
Recommended Vacuum Chamber Flange

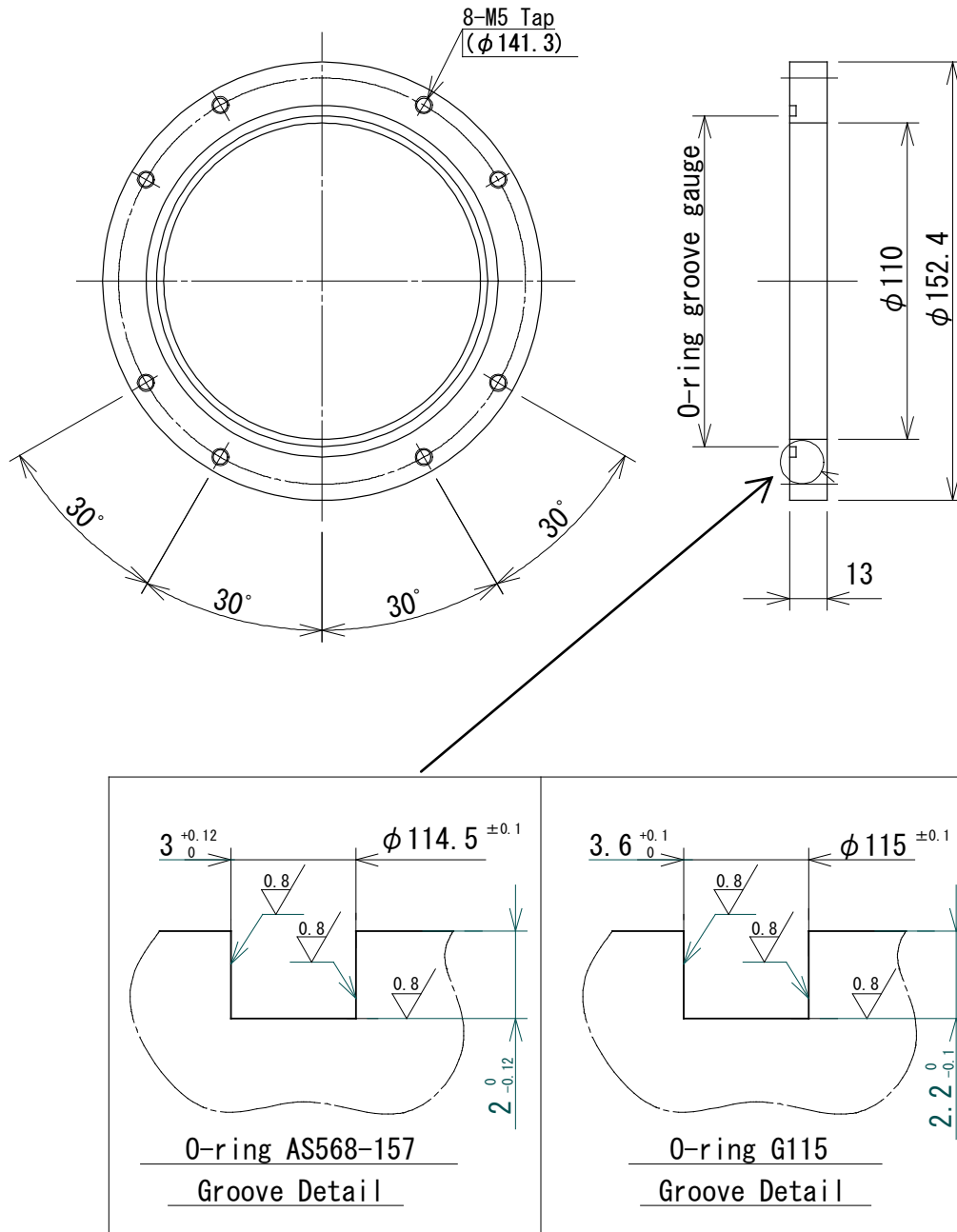
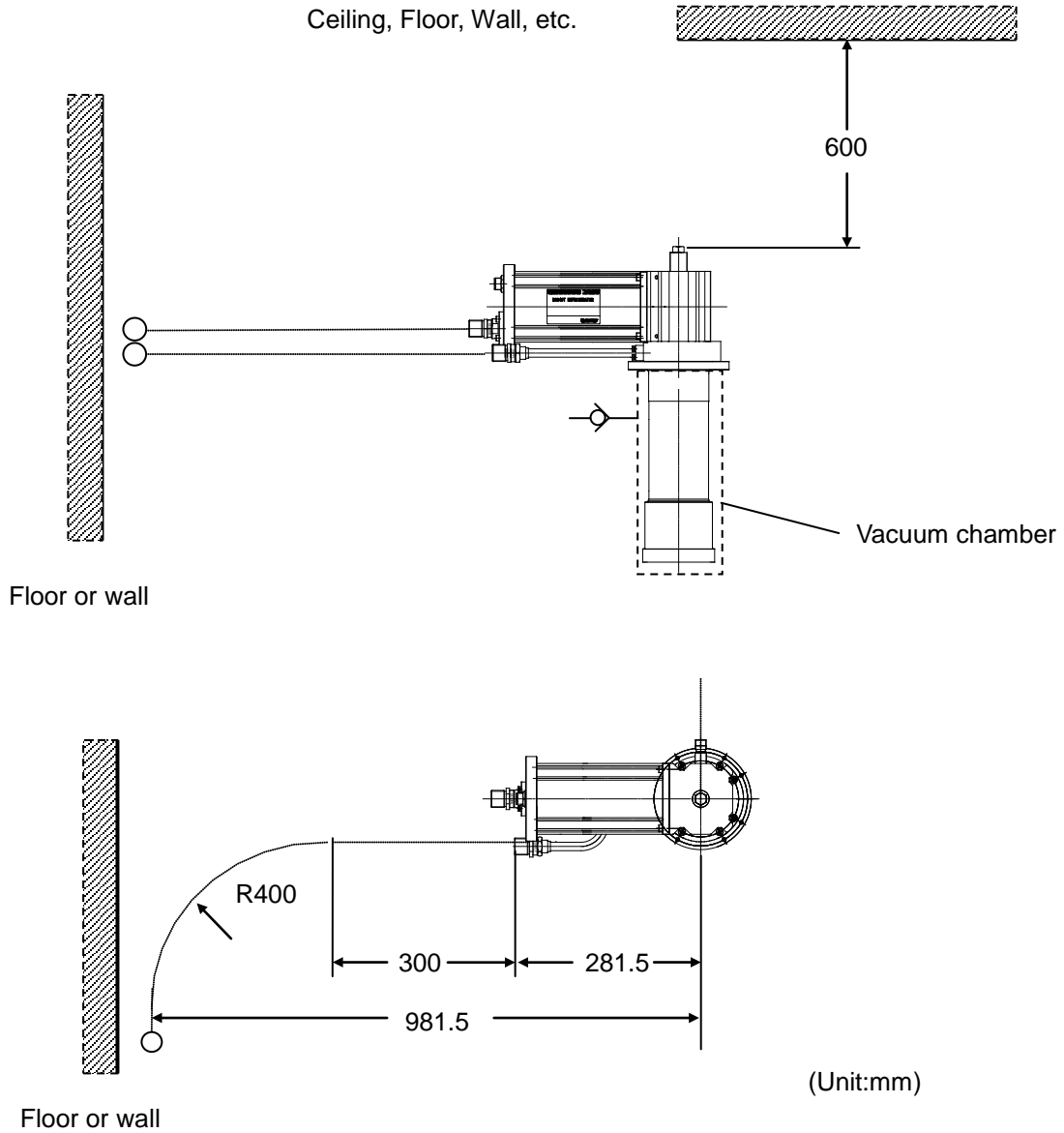

Figure 3-1 Mounting Flange for 20K Cryocooler RSC50T

**3.2 Mounting 20K cryocooler to a Vacuum Chamber**

- ◇ Install the 20K cryocooler in a vertical orientation with the first stage pointing down.
- ◇ When installing the 20K cryocooler, secure a maintenance space. Figure 3-2 shows a necessary space for maintenance.



**Figure 3-2 Maintenance space for the 20K Cryocooler**

### 3.3 Connecting Roughing Pump

1. Connect roughing pump system to the vacuum chamber.
2. Install a pirani gauge between vacuum chamber and roughing pump. It is recommended to install the gauge close to the vacuum chamber as much as possible.
3. It is recommended to add a fore-line trap in the roughing line in order to prevent the oil back stream into the vacuum chamber at rough pumping to 40Pa or lower by oil-sealed rotary pump. Regenerate the fore-line trap occasionally.

### 3.4 Connecting Cooling Water Pipe



#### CAUTION

Regarding cooling water of the compressor unit, observe the water quality criteria which is shown in the compressor unit instruction manual.

1. Connect cooling water pipe to the compressor unit. The connector thread size for both "COOLING WATER IN" and "COOLING WATER OUT" is Rc 3/8 female pipe thread.
2. Be careful not to mistake the inlet for the outlet.
3. Run the cooling water with the actual flow conditions, and make sure that there is no water leakage.

Please read the compressor unit instruction manual for more information on the connecting method or the requirements for water pressure and flow rate.

### 3.5 Connecting 20K cryocooler to Compressor Unit (Connecting Flexible Hose)



#### CAUTION

- Read the handling notes in appendix B about the connection of the flexible hoses.
- When connecting flexible hoses, always use two single open end spanners with width across flat 26mm and 30mm.
- Do not forcibly bend flexible hoses. They may be damaged and cause helium leakage.
- Do not connect or disconnect self-sealing coupling frequently. It may cause gas leakage. If there is a leakage, you may have to replace it with a new one according to the situation of the occurrence of Leakage.



1. Remove all dust plugs and caps from supply and return flexible hoses, compressor unit and 20K cryocooler. Clean flat rubber gaskets on the self-sealing couplings to be free from dust or metallic powder.
2. Connect the flexible hoses between the compressor unit and the Cryocooler as follows (see Figure 3-3):
  - a. Connect one end of the SUPPLY labeled flexible hose to high pressure side connection port of the compressor unit and another end to high pressure side connection port (labeled SUPPLY) of the cryocooler.
  - b. Connect one end of the RETURN labeled flexible hose to low pressure side connection port of the compressor unit and another end to low pressure side connection port (labeled RETURN) of the cryocooler.
3. Check the helium gas charge pressure on the compressor unit (\*Please refer to the compressor unit instruction manual). If the pressure is higher than the appropriate value, release helium gas by opening the gas charge valve slowly. If the pressure is too low, charge helium gas as described in Section 6.2 in this manual.

### 3.6 Connecting Remote Wiring

For remote operation, a remote wiring is necessary.

Please refer to the compressor unit instruction manual for the electric machine design specification concerning the remote operation.

### 3.7 Connecting Electrical Cables

	 <b>WARNING</b>
Do not connect the compressor unit power cable until all other connections have been made between the components and the 20K cryocooler system.	

1. Connect the refrigerator power cable from the compressor unit to the 20K cryocooler.
2. Connect the earth ground.
3. Connect the input power cable from the compressor unit to its power source.
4. The method of starting the compressor unit differs depending on the models. Read the compressor unit instruction manual for more information.



- ① Hold the coupling straight and tighten the self-sealing coupling by hand.

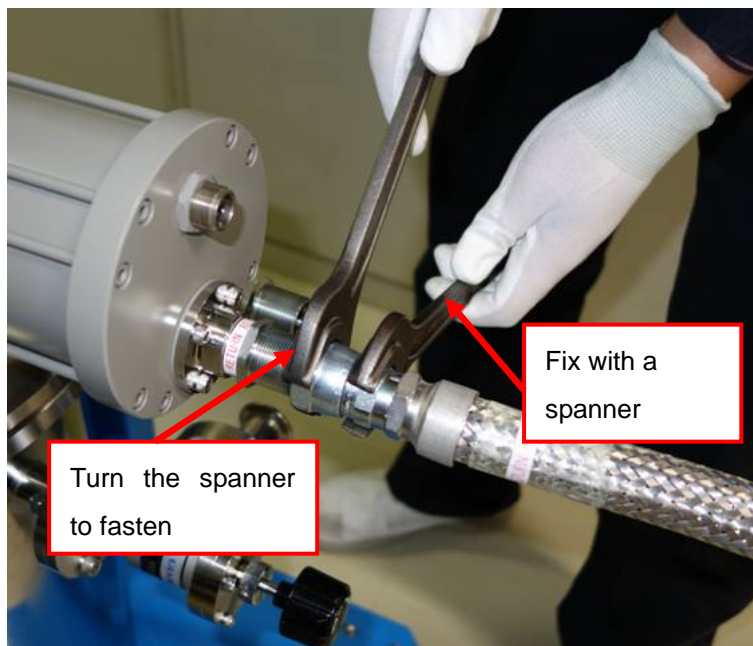

- ② Fix the hexagon part with a wrench
- ③ Turn the union nut with another wrench to fix. The recommended torque is  $20\text{N}\cdot\text{m}$ .

**Figure 3-3 Connecting Flexible Hoses**

This page intentionally left blank.



## 4. OPERATION

4.1	Prior to Startup .....	4-1
4.2	Mounting Test Samples .....	4-1
4.3	Rough Pumping.....	4-1
4.4	Startup and Cooldown .....	4-2
4.5	Normal Operation .....	4-2
4.6	Shutdown Procedures.....	4-3
4.7	Handling of Hazardous Materials.....	4-4

### 4.1 Prior to Startup

Before starting operation, check the followings:

1. The flexible hoses and cables are properly connected.
2. The gauges are mounted on each intended ports.
3. The roughing valves are closed.
4. The helium gas pressure gauge on the compressor unit shows the specified value.

It is recommended to carry out daily check and keep an operating log to notice the first sign of a trouble as early as possible. This will help you to get prompt technical assistance from us. The recommended operating log is attached to Appendix A.

### 4.2 Mounting Test Samples

Mount a sample (hereinafter "load") to be cooled on the 1st stage of the 20K cryocooler with indium sheet. Indium sheet is needed to improve thermal conduction between the load and the stage.

### 4.3 Rough Pumping

1. Start up the roughing pump.
2. Open the roughing valve and then rough pump the vacuum chamber to 1Pa or lower.
3. When rough pumping is completed, close the roughing valves and turn off the roughing pump.

(When the volume of outgas in the vacuum chamber is large, start the operation of the 20K Cryocooler while pumping the vacuum chamber with a high-vacuum pump.)

#### 4.4 Startup and Cooldown

1. Start up the compressor unit. The Cryocooler automatically starts operation.  
Collect data during the cooling operation every 5 minutes, and record it on the operation data sheet (Table A-2).
2. Wait until the 1st stage temperature of 20K cryocooler is stabilized. The ultimate temperature should be lower than 13K.

(Note) The cooldown time and the ultimate temperatures of the stages vary depending on the ambient conditions.

Refer to Table 1-2 for the cooldown time of the 20K cryocooler.



#### CAUTION

If a 20K cryocooler system runs at poor vacuum condition, water condenses inside the vacuum chamber. It may cause short-circuit if any electrical device is under the chamber.

#### † For Your Information †

- In order to minimize the cooldown time, avoid heat load (heaters, for example) to the testing sample during cooling.
- Cooldown failure or prolonged cooldown time may result when:
  - ① Testing sample is too large.
  - ② Incoming thermal load from radiation heat is too heavy.
  - ③ Pressure inside vacuum chamber is too high.

#### 4.5 Normal Operation

The 20K cryocooler can be operated without an operator.

Please record the operating data on operating logs during normal operation regularly.

Refer to corresponding instruction manuals for the operating pressure of the compressor unit.



#### 4.6 Shutdown Procedures







1. Shutdown the compressor unit. 20K cryocooler automatically stops. Exhaust gases that are condensed in the vacuum chamber.
2. It becomes at the normal temperature in the vacuum chamber, the exhausting gases is completed and the 20K cryocooler will be kept stop.
3. If you continue to conduct inspection, replacement, or repair of the 20K cryocooler, turn off the main power supply and stop circulating the cooling water before beginning the work required.

If there is no thermal load to the 20K cryocooler, it takes long to warm up the cryocooler to the room temperature. Although it depends on the thermal capacity of load, it takes at least 12 hours under vacuum thermal-insulating condition to bring the low-temperature part of the cryocooler up to room temperature after the cryocooler is stopped.

■ To reduce warm-up time

Introduce clean and dry gas such as nitrogen with dew point temperature of  $-40^{\circ}\text{C}$  or below or argon until the vacuum chamber reaches to atmospheric pressure.

	 <b>WARNING</b>
<p>When gas is introduced into the vacuum chamber to shorten the warm-up time, the condensed gas in the vacuum chamber evaporates as the cryocooler warms up, and the inside pressure may exceed atmospheric pressure. After pressure in the vacuum chamber becomes atmospheric pressure, exhaust the evaporated gas by opening a roughing valve etc.</p>	

					 <b>WARNING</b>
<p>When toxic, corrosive, flammable, and explosive gases were or may have been pumped with the 20K cryocooler, never use the warm-up method of exposing the vacuum chamber to the air after bringing it to atmospheric pressure. Exhaust the captured gas to the pre-installed dedicated duct or dedicated exhaust facility diluting it with inert gas, such as nitrogen that its dew point temperature is <math>-40^{\circ}\text{C}</math> or below or argon. Toxic or corrosive gases must be appropriately detoxified or made inert before they are exhausted outdoors.</p>					

**CAUTION**

Maximum allowable temperature of the refrigerator unit is 70°C. If you use a heater, make sure to control the heater temperature so that the temperature of the cold head (1st stage) does not exceed 70°C. If it exceeds 70°C, inside of the refrigerator may be damaged by the heat and the refrigerator replacement may be needed.

Please take appropriate measures to prevent the temperature of the cold head from unexpectedly becoming hot when baking or heating a vacuum chamber with a heater.

**4.7 Handling of Hazardous Materials****WARNING**

- ◆ Do not exhaust large amount of toxic, corrosive, flammable and explosive gases.  
Especially, the vacuum chamber should not exceed atmospheric pressure with those gases.  
Please refer to Safety Instructions for these hazardous gases.
- ◆ When exhausting toxic or corrosive gases, obtain proper instructions from a safety supervisor.
- ◆ Clearly identify toxic, corrosive, dangerous gases, or liquids on containers used to store or ship equipment after such exposure.
- ◆ Handle dangerous materials with care in accordance with applicable law and regulations.

## 5. DISCONNECTION AND STORAGE

5.1	Disconnecting Flexible Hose .....	5-1
5.2	Storage.....	5-2

### 5.1 Disconnecting Flexible Hose



#### CAUTION

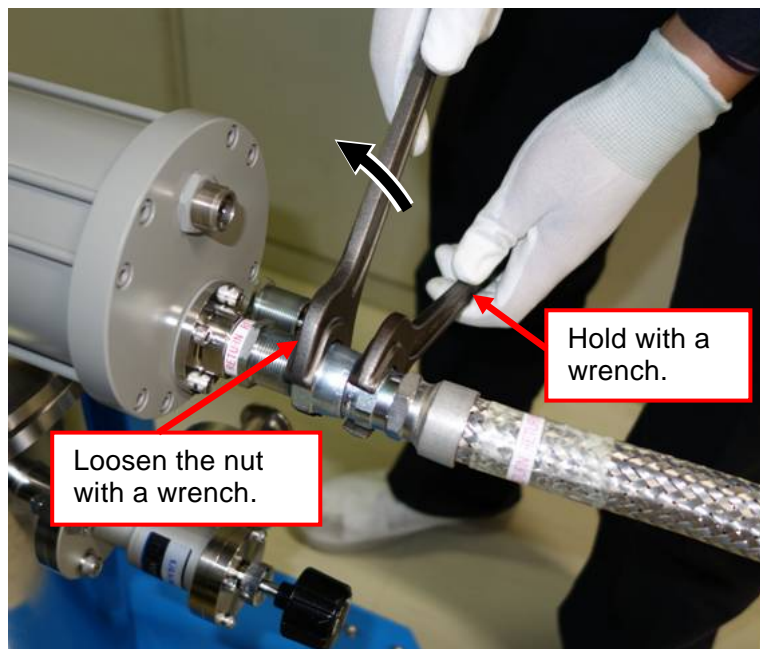

When disconnecting flexible hoses, be sure to use two single open end wrenches with width across flat 26 and 30.

1. Shut down the compressor unit.
2. Disconnect flexible hoses after the 1st stage of 20K cryocooler returns to room temperature.



Loosen the union nut using two spanners and disconnect the flexible hose by hand.

**Figure 5-1 Disconnecting Flexible Hose**

	 <b>WARNING</b>
<p>If the flexible hose is disconnected immediately after the 20K cryocooler is shutdown, low-temperature helium gas accumulated in the low-temperature part of the cryocooler expands as the temperature rises and the pressure in the cryocooler increases. This may activate the pressure relief valve of the cryocooler and cause helium leak. When you need to disconnect flexible hoses for maintenance or other purposes, check that the cryocooler warms up to room temperature before disconnecting. It takes at least 12 hours under vacuum insulated condition to bring the low-temperature part of the cryocooler to room temperature after the cryocooler system is shutdown although the time may vary depending on the type or weight of samples.</p> <p>* When helium gas replacement is to be performed, the flexible hose on the compressor unit side must be disconnected immediately after the operation is stopped. For the detail on helium gas replacement of the cryocooler, refer to Section 6.3.</p>	

## 5.2 Storage

- ◆ If a 20K cryocooler is stored attached to your vacuum chamber, the vacuum chamber should be kept in a vacuum (of 100Pa or less) or vacuum-encapsulate the chamber with dry nitrogen (atmospheric pressure) so that it will not be exposed to the air.
- ◆ If a 20K cryocooler is removed from your vacuum system,
  1. After a whole part of the cryocooler has reached room temperature, disconnect the flexible hoses.
  2. Before removing the cryocooler from the vacuum chamber, make sure that the cryocooler has reached room temperature after regeneration.
  3. Put the protective cap on the helium gas connector of the cryocooler .  
Be careful not to damage the 1st stage and sealing surface.
  4. Cryocooler should be kept away from direct sun light, high temperature, humidity, dust, vibration, radiation, wind and rain.

◆When storing a cryocooler over a long period

Connect the refrigerator cable and operate the cryocooler for about 10 minutes biannually. This work is effective in maintaining the grease lubrication of the bearings used in the cryocooler.

When the cryocooler has been placed without operating for one year or more, perform cryocooler decontamination before resumption of operation.

◆When transporting a 20K cryocooler

Return the cryocooler to the state at the time of shipment, and prevent excessive shock.

This page intentionally left blank.



## 6. MAINTENANCE

6.1	Scheduled and Unscheduled Maintenance .....	6-1
6.2	Charging Helium Gas .....	6-2
6.3	Helium Circuit Decontamination .....	6-5

### 6.1 Scheduled and Unscheduled Maintenance

- ◇ Scheduled Maintenance :
  - Replacement of maintenance parts in the 20K cryocooler
  - Replacement of the compressor adsorber
- ◇ Unscheduled Maintenance :
  - Adding helium gas
  - Helium Circuit Decontamination

Following items and helium gas are necessary for charging helium gas or helium line decontamination.

	Item	Volume	Item code
1	Helium charging adapter kit (Regulator, Charging hose 2.4M, Charging adapter)	1	A700B5101000
2	<Items independently available>		
	Regulator (for helium gas)	1	A700A5101700
	Charging hose 2.4M	1	A700A5101800
	Charging adapter	1	A700B5101100
3	Helium gas (with purity of 99.999% or above)	—	—

**Table 6-1 Recommended Maintenance Cycle and Parts**
**S:** Scheduled maintenance    **U:** Unscheduled maintenance or part replacement at fault

	Actions	Parts	Intervals	Notes
20K cryocooler				
<b>S</b>	Seal kit replacement	Seal kit	12,000hr	Maintenance intervals may differ depending on the frequency of operation.
<b>S</b>	Driver assembly replacement	Driver bearing, Valve bearing Set screw		
<b>S</b>	Motor bearing replacement	Motor bearing		
<b>S</b>	Displacer replacement	1 <sup>st</sup> stage displacer		
<b>S</b>	Valve body replacement	Intake/Exhaust valve body		
<b>S</b>	Cylinder bolts	Cylinder bolt		
<b>U</b>	Other parts replacement	Other parts	At fault	
Compressor unit				
<b>S</b>	Adsorber replacement	Adsorber	Refer to the compressor unit instruction manual.	

**NOTE**

Maximum allowable temperature of 20K cryocooler unit is 70°C. If you use a heater, make sure to control the heater temperature so that the temperature of the cold stages of the cryocooler does not exceed 70°C. If the cold head is heated over 50°C during regeneration repeatedly, more frequent maintenance is required since the displacer may deteriorate faster than usual.

## 6.2 Charging Helium Gas

Please supply the equipments for charging helium gas (regulators, charging hoses) that can be used at 2.0MPaG or above.

**CAUTION**

If the helium pressure gauge of the compressor unit shows 0 MPaG, contamination caused by air or moisture may occur in the system. If it occurs, contact our Service Engineering Division or customer support center.

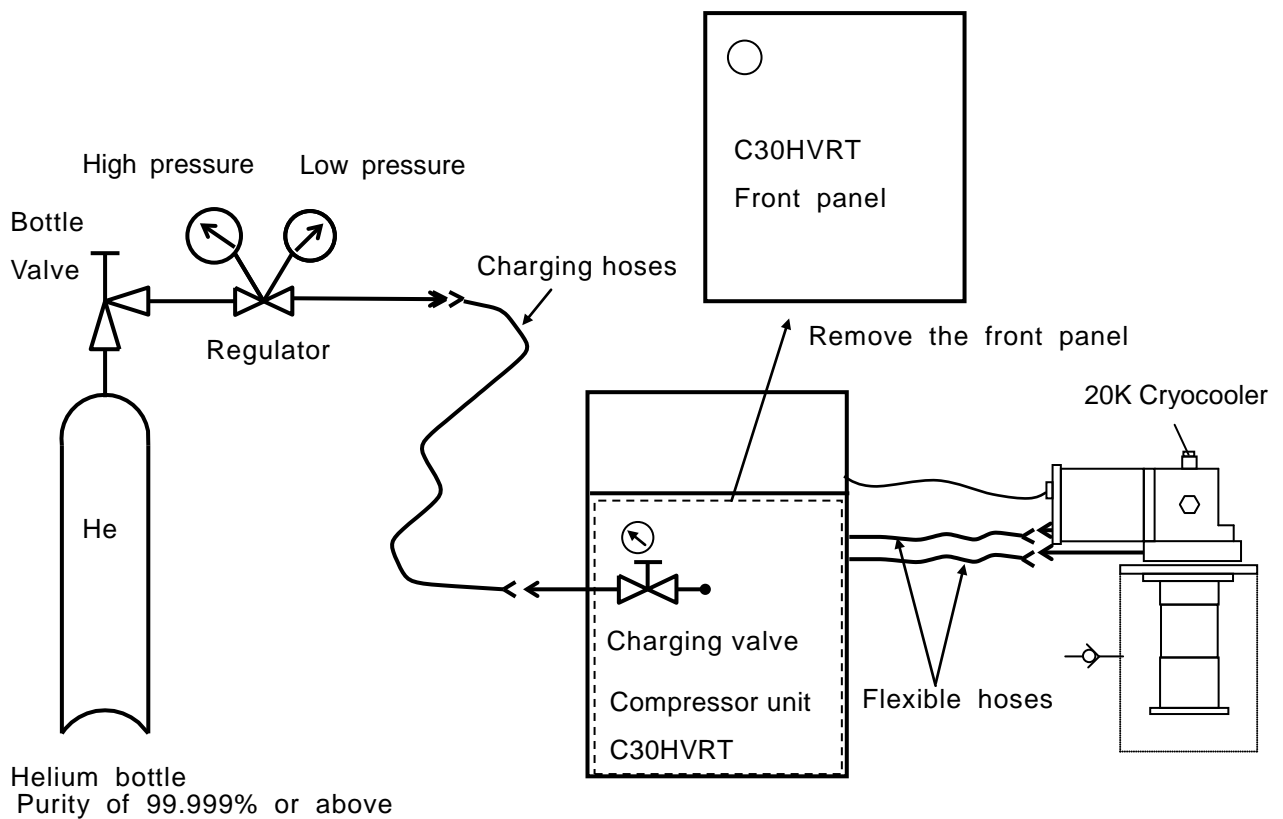

**Figure 6-1      Charging Helium Gas**

When helium gas pressure declines, it is necessary to add helium (Figure 6-1). Identify the cause of pressure down before adding helium gas. If there is a leakage, take an adequate measure before charging. Improperly connected self-sealing coupling might be one of the causes of the leakage.

- ◇A regulator with low-pressure side pressure gauge of 4-6 MPaG is recommended.
- ◇The gas charge fitting of the compressor unit is 1/4B male flare.
- ◇**Use helium gas with purity of at least 99.999%.**

Follow the procedures below to charge helium gas:

1. When mounting the regulator on a new helium bottle, perform the following procedures in order to purge the air and fill helium gas in the gas line between the regulator and the bottle valve.
  - a. Open the regulator a little. (The regulator normally opens by turning the handle clockwise.)
  - b. Slowly open the bottle valve, and purge the regulator and gas line for several seconds.
  - c. Turn the regulator handle counter-clockwise to close the regulator.

**CAUTION**

Do not open the bottle valve immediately after attaching a regulator, as it diffuses the air between the regulator and bottle valve into the helium bottle and contaminates helium gas.

**WARNING**

Never bring your face in front of the pressure gauge when opening the bottle valve or turning the regulator handle.

2. Make sure that the compressor unit is at room temperature, and remove the front panel.  
If it is not at room temperature, leave it for three hours so that it reaches to the room temperature before starting the work.
3. Connect the helium charging hose as follows:
  - a. Connect the charging hose to the regulator.
  - b. Loosely connect the charging hose to the charge inlet on the compressor unit.
  - c. Open the regulator until the low pressure side reaches 0.1 - 0.2 MPaG. Allow helium gas to flow out from the charging hose for about half a minute. Meanwhile, open the charge valve slightly in order to drive out the air that exists between the charge valve and the charge inlet.
  - d. Tighten the flair nut at the end of charging hose and close the charge valve. Helium gas charge in the line between the regulator and the charge valve on the compressor has been completed.
4. Adjust the low pressure side of the regulator to 1.8 MPaG.
5. Open the charge valve slowly and charge helium gas until it reaches to the static charge pressure.

**CAUTION**

If helium gas has been charged more than the prescribed pressure of 1.9MPaG or more, the pressure relief valve on the refrigerator may be activated. Therefore charge helium gas slowly so that the pressure relief valve should not operate. The pressure relief valve in the compressor unit is set at 2.5MPaG.

6. Close the charge valve after charging helium gas.
7. Close the regulator and remove the charging hose from the charge fitting.

### 6.3 Helium Circuit Decontamination

Customers are requested to supply the equipments for charging helium gas (regulators, charging hoses, adopters) that can be used at 2.0MPaG or above.

When helium gas in the 20K cryocooler system looks contaminated, it is necessary to replace the gas in the system with pure helium gas. (Refer to “Appendix A Trouble shooting”)

Contamination of helium gas in the cryocooler system is caused by inadequate helium decontamination at the time of cryocooler maintenance. If impurities in helium gas are coagulated and deposited into the cryocooler, the performance of cryocooler could be deteriorated and abnormal vibration of the motor (called Step-out\*) may occur. Please execute decontamination of the gas by the following method.

(\*) Step-out: means that a Cryocooler motor has an irregular or intermittent movement.

1. Turn on the cryocooler system and keep the system running for three to four hours.

NOTE: Since all impurities in the helium gas are condensed and solidified in the cryocooler during operation, it is required to cooldown the cryocooler for some time before performing helium decontamination procedures. If an irregular or abnormal sound or vibration arises during operation, proceed to the next step (2) immediately.

2. Shut down the Cryocooler system and turn off the compressor unit.

- a. Close the main valve of the vacuum system.
- b. Turn off the compressor unit.

3. Immediately after shutting down, remove both SUPPLY and RETURN flexible hoses from the connectors on the compressor side (see Figure 6-2). Keep both SUPPLY and RETURN flexible hoses connected on the Cryocooler side.

NOTE: The reason that the flexible hoses should be removed immediately is to prevent the impurities condensed and solidified inside the cryocooler from being evaporated and deteriorating the purity of helium gas in the compressor unit.

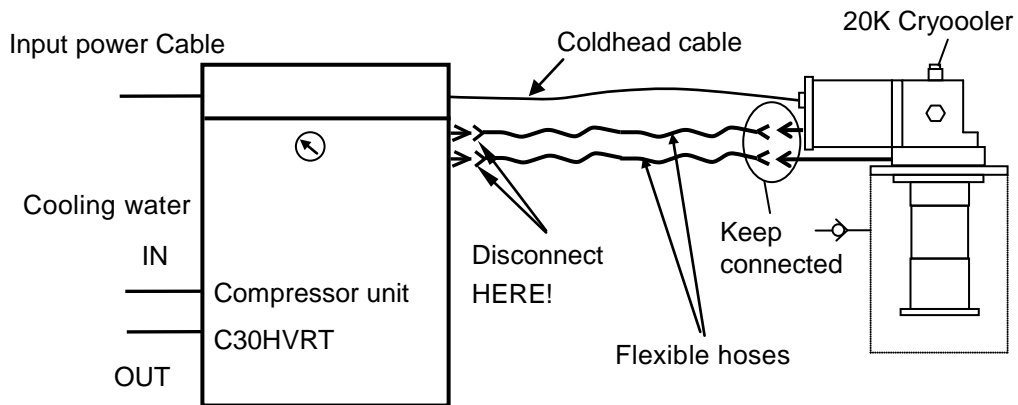

**Figure 6-2 Disconnecting Flexible Hose**

4. Attach the charging adaptor to the disconnected ends of the helium SUPPLY and RETURN flexible hoses. (See Figure 6-3)

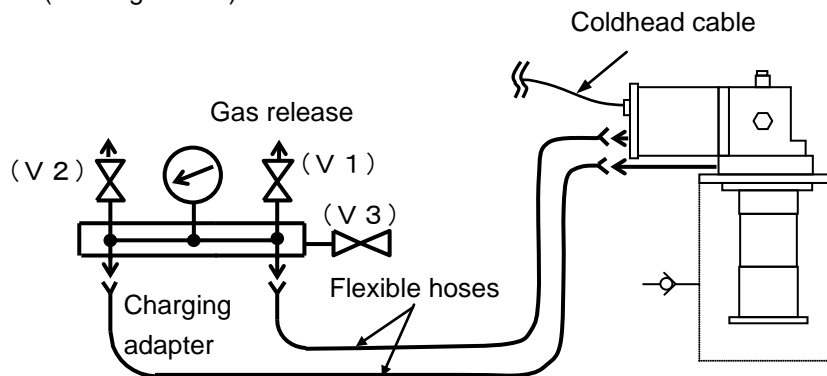

**Figure 6-3 Connecting Charging Adapter**

5. Reduce the pressure in the 20K cryocooler and the flexible hoses to a level of 0.3MPaG by opening the valve (V1) of the charging adaptor.

**NOTE:**

By cooling down the cryocooler at the beginning of the decontamination procedures, the temperature of helium gas in the cryocooler decreases and the density of the gas increases. After shutdown of the cryocooler system, the temperature of the helium gas in the cryocooler gradually returns to room temperature from cryogenic temperature and the inner pressure rises as the temperature increases. The cryocooler has a pressure relief valve which opens when inner pressure reaches 1.9MPaG. Once the pressure relief valve opens, it could cause a leakage depending on the surrounding environment such as dust. Therefore, ensure to reduce the inner pressure right after shutting down the cryocooler system in order to prevent the pressure relief valve from

working.

6. Leave the 20K cryocooler until it reaches room temperature. Although it depends on the weight of the cooled object, normally it takes about 12 hours under vacuum thermal-insulating condition

**Before proceeding to the next procedure, make sure that the cryocooler has reached room temperature.**

7. Connect the helium bottle and the regulator. Replace the air remained between the helium bottle valve and the regulator with helium gas as instructed in "Section 6.2 Charging Helium Gas".

**Use helium gas with purity of 99.999% or above.**

8. Perform decontamination procedures as follows:

Before proceeding decontamination, prepare the rough pumping system as indicated in Figure 6-4. A roughing pump with the pumping speed of 20L/min or more and the ultimate pressure of 10Pa is recommended.

A dry pump is recommended as a roughing pump as it does not cause backward flow of oil.

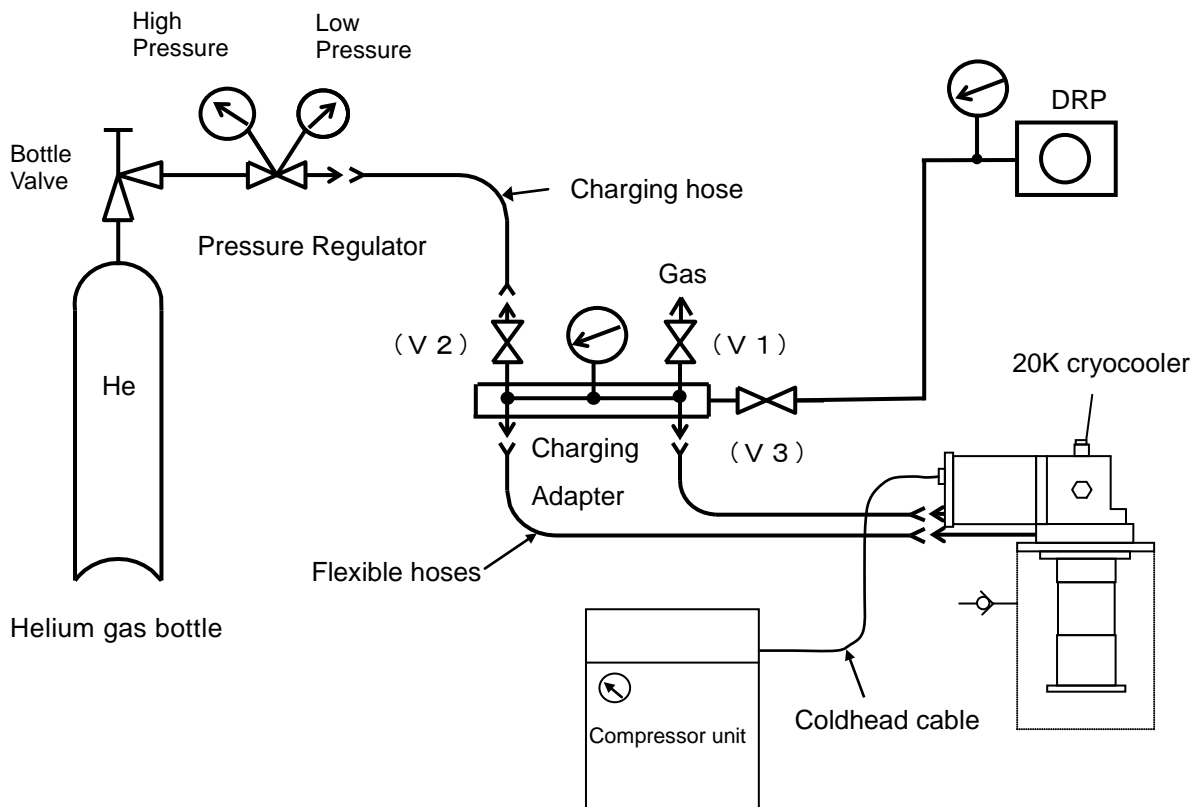

**Figure 6-4 Cryocooler Decontamination Procedures (1)**

- a. Loosely connect the charging hose to the charge valve (V2) on the charging adapter.
- b. Open the regulator that low pressure side of the regulator reaches 0.1 - 0.2 MPaG. Allow helium gas to flow out from the charging hose for about half a minute. Meanwhile, open the charge valve (V2) slightly in order to drive out the air trapped in the charge valve.
- c. Tighten the flair nut at the end of charging hose and close the valve (V2).
- d. Start the roughing pump and open the valve (V3) slightly. Exhaust the helium gas in the cryocooler while maintaining pressure below an allowable value of the roughing pump. After the pressure reaches below the atmospheric pressure, the valve (V3) can be fully opened. Monitor the pressure of the roughing pump with an appropriate pressure gauge. The maximum allowable pressure of ULVAC's small oil-sealed rotary pump and drypump is 0.01MPaG.

**CAUTION**

Make sure to open the valve slowly when exhausting the gas beyond the atmospheric pressure in order to maintain the pressure of the pump head below an allowable value. If it is opened quickly and widely, the roughing pump may break down.

- e. After rough pumping for more than 30 minutes, close the valve (V3). Shut off the roughing pump to bring it back to the atmospheric pressure.
- f. Adjust the low pressure side of the regulator at 1.8MPaG. Then open the valve (V2). Charge helium gas until the pressure gauge on the charging adapter reaches 1.5MPaG and then close the valve (V2).
- g. Start the compressor unit to operate the cryocooler. When operating the cryocooler, the helium gas is circulated through the cryocooler, the flexible hose, and the charging adapter. See Figure 6-5.



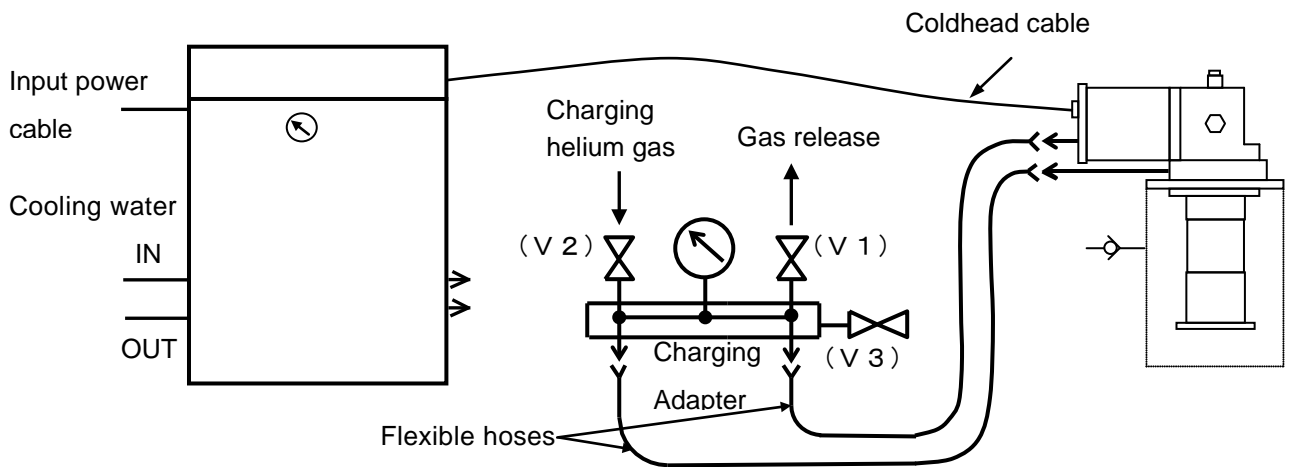

**Figure 6-5 Cryocooler Decontamination Procedures (2)**



### CAUTION

Do not operate the cryocooler unit when it is at negative pressure. It may cause a vacuum discharge in the motor of the cryocooler, and bring about a breakdown.  
Helium gas charge has to be completed before starting the cryocooler.

- h. While the 20K cryocooler is running, open the valve (V1) to release gas until the pressure goes down to 0.4MPaG, and then close the valve (V1).
- i. While running the Cryocooler, repeat the following operation 25 times slowly.
  - 1) Open the valve (V2) and charge helium gas until the pressure gauge shows 1.5MPaG and then close the valve (V2).
  - 2) Open the valve (V1) and depressurize to 0.4MPaG and then close the valve (V1).  
By taking helium gas in and out 25 times, the purity of helium gas inside the cryocooler and the flexible hoses will be improved.
9. Shut down the cryocooler and charge helium gas to the cryocooler and flexible hoses until the appropriate charge pressure of the compressor unit.
10. Remove both SUPPLY and RETURN flexible hoses from the charging adapter.
11. Make sure that the flat rubber gasket of the self-sealing couplings are properly set. Then connect each flexible hose to the compressor unit. (See Figure 6-6)

**CAUTION**

If the SUPPLY / RETURN flexible hoses are not properly connected to the SUPPLY / RETURN connectors on the compressor unit, the pressure relief valve on the cryocooler will work. If it works, maintenance work will be required. Make sure that the SUPPLY / RETURN flexible hoses are connected to the correct connectors.

12. Confirm that the pressure gauge of the compressor unit indicates the specified pressure.  
If not, charge helium gas through the charging valve of the compressor unit, or adjust the pressure by discharging helium gas.
13. Restart the cryocooler system.

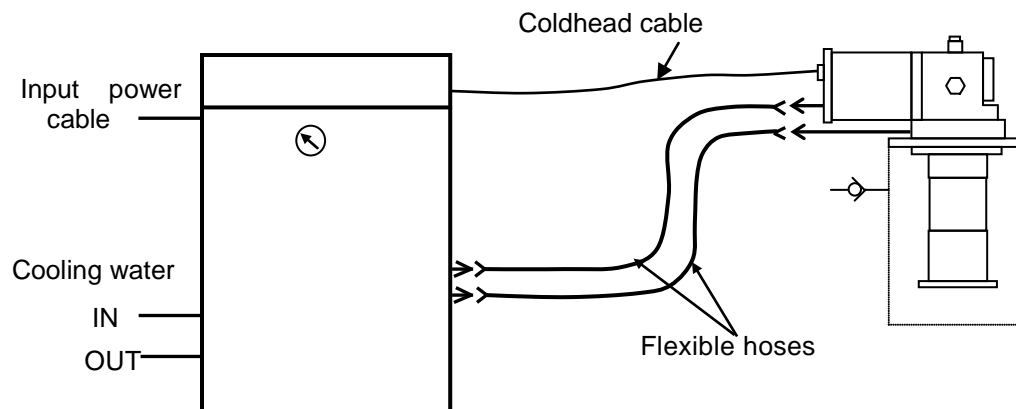

**Figure 6-6 Connecting Flexible Hoses**

## Appendix A

### Troubleshooting

Regarding various potential failures, each item I to IV in Table A-1 explains its cause and measure respectively. When the trouble cannot be solved, please contact our Service Engineering Division or the nearest customer support center.

	 <b>WARNING</b>
Shut down all power supply before troubleshooting.	

Table A-1 20K Cryocooler Fault Diagnosis

Problem	Possible Cause	Corrective Action
I. It takes longer than usual to cool down or the cryocooler is not cooled properly.	1) Helium Supply/Return line are not connected properly. Self-sealing coupling is not properly tightened.	Connect the flexible hoses properly referring to Section 3.5. Check that all self-sealing couplings are connected properly.
	2) Pressure in the vacuum chamber is too high.	Make sure that there is no leakage. The cryocooler may fail to cool down due to thermal load of the gas caused by a leakage.
	3) Helium fill pressure in the compressor unit is deficient.	Refer to Section 6.2 and add helium gas.
	4) Heat load to the cryocooler is too high.	Take measures to reduce the heat load.
	5) Helium gas is severely contaminated.	Perform decontamination as described in Section 6.3. Use helium gas with purity of 99.999% or more.
	6) Failure of the cryocooler or the compressor unit.	Contact our Service Engineering Division or the nearest CS center.

Problem	Possible Cause	Corrective Action
<p>II. Neither the compressor unit nor the cryocooler starts.</p>	<p>Refer to the instruction manual of compressor unit for details.</p>	
<p>III. A compressor unit starts, but a cryocooler doesn't start.</p>	<p>1) A cryocooler power cable is not connected to the cryocooler.</p>	<p>Turn off the compressor unit and connect the cryocooler power cable to the cryocooler.</p> <div style="border: 1px solid black; padding: 5px;"> <p> <b>CAUTION</b> Do not connect the cryocooler power cable to the cryocooler without turning off the compressor unit. The cryocooler motor may be damaged if this caution is not followed.</p> </div>
	<p>2) The drive motor of a cryocooler has mechanical damage.</p> <p>① Motor shaft failure or bearing defects.</p> <p>② Drive motor circuit failure.</p>	<p>Check whether you can hear motor running sound by turning on and off the switch of the cryocooler.</p> <p>When no sound or irregular beat comes from the motor, contact our Service Engineering Division or the nearest CS center.</p> <p>Measure resistance and insulation resistance between the drive motor connector pins (Impressed voltage: 500V) and Inform us the measured values with S/N of the cryocooler.</p>
<p>IV. Cryocooler drive motor is making irregular or intermittent motion.</p>	<p>1) Helium gas is heavily contaminated.</p> <p>2) Input voltage to the motor is low.</p>	<p>Perform Cryocooler decontamination procedures as described in Sec.6.3. Use helium gas with purity of 99.999% or more.</p> <p>Check the input voltage to the cryocooler.</p>



This page intentionally left blank.

## Appendix B

### FLEXIBLE HOSE

#### 1. Specifications

- Gas : Helium Gas (Purity : 99.999% or more)
- Pressure : Max. 2.4MPaG
- Temperature : 0 - 70°C
- Material : SUS304
- Length : 20m (standard)
- Minimum Bending Radius : 250mm
- Recommended Torque for Connecting: 20N·m

**Fasten self-sealing couplings until tight enough.**

- Connection : 1/2B self-sealing coupling

#### 2. Precautions in Handling



#### CAUTION

- When carrying the flexible hose, hold the braid support of the hose. If it is bended forcibly at an acute angle, it may be damaged.
- Avoid twisting the flexible hose especially when making final connection.
- Keep away from water and salt to prevent corrosion. Do not put heavy things on flexible hoses in order to prevent being deformed or crushed.

This page intentionally left blank.



## Appendix C

### PRINCIPLE OF CRYOCOOLER OPERATION

Helium gas is used as heat-medium gas of a refrigeration cycle in Cryocooler system, because it does not liquefy even 10K.

First, after the helium gas is compressed into high pressure and being continuously cooled by water-cooling or air cooling to room temperature within the compressor unit, it will be introduced into the refrigerator when the valve A opens. Then the helium gas is cooled by heat exchange between the regenerator and led to an expansion chamber with a rise of a displacer. Next, because the valve B opens at the same time the valve A closes, the high-pressure helium gas in the expansion chamber is exhaled toward the low pressure part of the compressor unit with the differential pressure. During this process, the pressure and temperature of the helium gas in the expansion chamber decreases (called Simon expansion). The cooled low-pressure helium gas is discharged completely from the expansion chamber by the descent of the displacer. As the helium gas passes through the regenerator again, it will be warmed up to room temperature and return to the compressor. At this moment, however, the regenerator is cooled down conversely. In this way, a refrigeration cycle returns to the first state. By repeating this refrigeration cycle, cryogenic temperature is obtained.

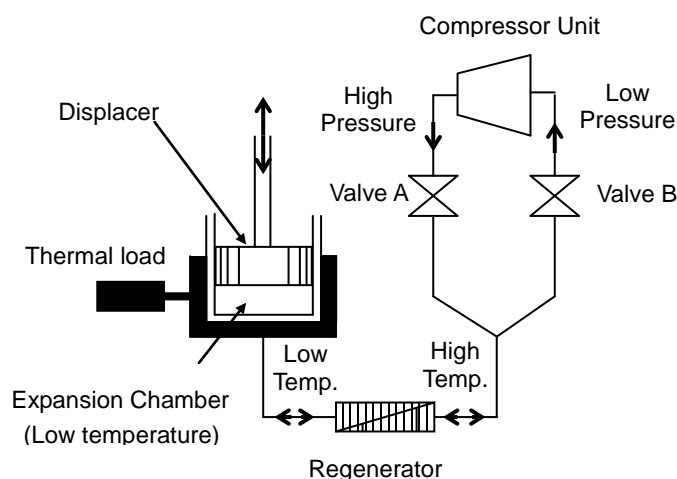

Figure C-1 Principle of Refrigeration

#### G-M Cycle

Gifford and McMahon developed the concept of G-M cycle in the late 1950's. In the driving method of G-M cycle, there are a way which drives mechanically and a way

which drives using the differential-pressure of the operational gas. Since the GM cycle is efficient, it can make drive speed late. Moreover, the load concerning the seal currently used for an inside is also light. Therefore, it is a highly efficient and reliable refrigeration cycle. In this manual, the refrigeration cycle with the mechanical driving system adopted by ULVAC CRYOGENICS INC is explained.

Figure C-2 shows the principle of G-M cycle & P-V chart (P: pressure, V: volume in the expansion chamber).

- A The displacer is first positioned at the bottom of the cylinder.  
 ↓  
 The low-pressure valve is closed and the high- pressure valve is opened.  
 ↓  
 a The compressed helium is introduced into the warm end and the cold end (the expansion chamber) of the cylinder.  
 ↓  
 B Pressure inside the cylinder increases.  
 ↓  
 b When moving a displacer up, the cold end (expansion room) is filled up with the helium gas of room temperature, being cooled by the regenerator.  
 ↓  
 C The volume of the cold end (the expansion chamber) is now maximum.  
 ↓  
 At this time the high- pressure valve is closed and low-pressure exhaust valve opened.  
 ↓  
 c The compressed helium in the cold end (the expansion chamber) is expelled through the regenerator causing a temperature decrease by Simon expansion.  
 ↓  
 D The cold end obtains the lowest pressure.  
 ↓  
 d The displacer is moved to the initial lower position and the low-temperature helium is transferred to the compressor. The temperature of the gas returns to room temperature by heat exchange between the regenerator.  
 ↓  
 A One cycle of the helium gas circulation is completed.

The P-V diagram of idealized G-M cycle shows a quadrangle.

The ideal refrigeration ability “ $Q_{ideal}$ ” is as follows when indicating the period of one cycle as “t” minutes:

$$Q_{ideal} = W / t$$

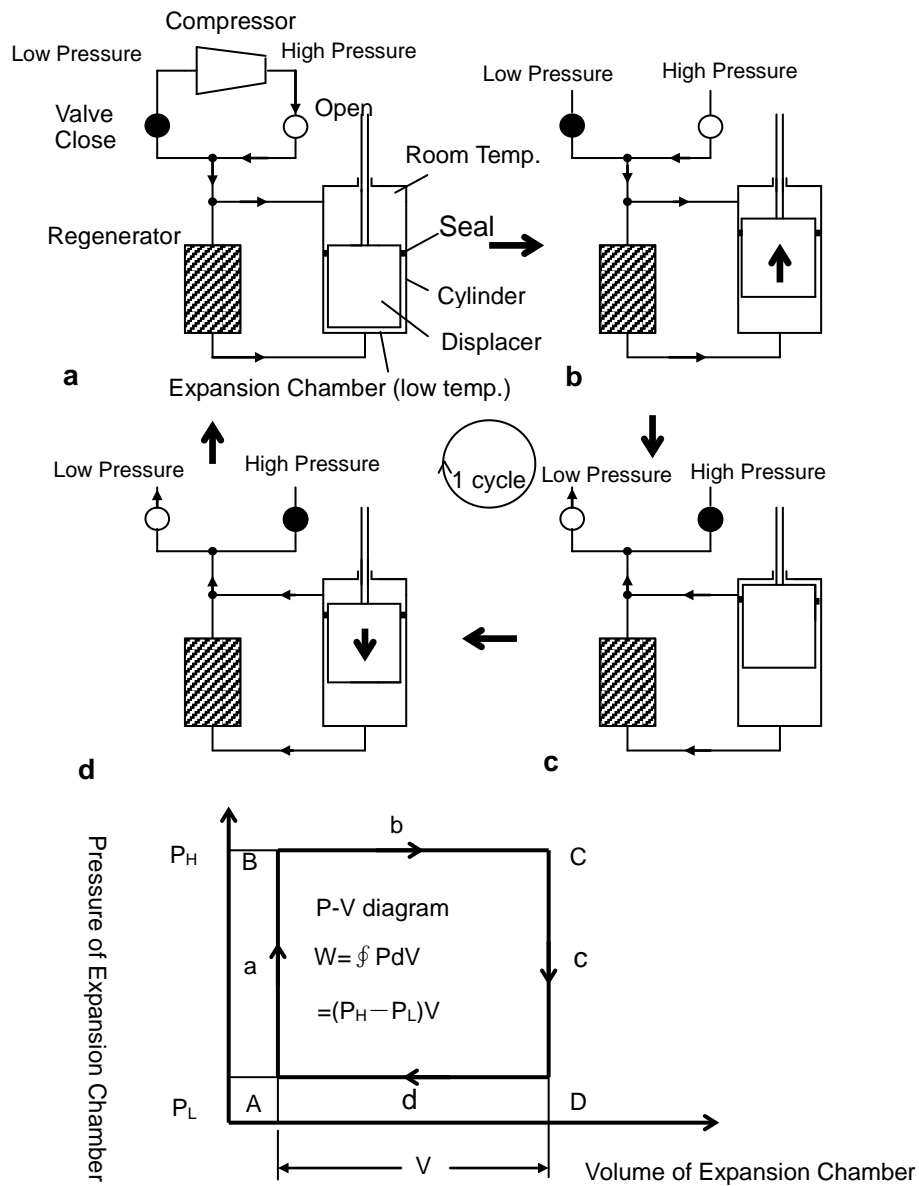

Figure C-2 Principle of G-M Cycle Operation

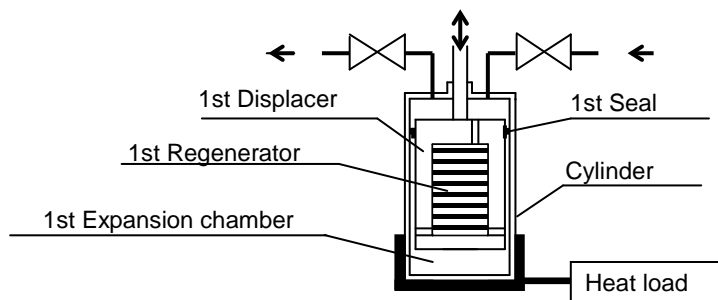

Figure C-3 Single stage cryocooler

This page intentionally left blank.

---

## Appendix D

### TYPICAL PERFORMANCE CURVE

(when installed in a vertical orientation with the first stage pointing down)

The performance curves of a cryocooler shown in this chapter are typical examples and these capacities are not always guaranteed.

RSC50T (C30HVRT) 50/60Hz..... D-2

**RSC50T (50/60Hz)**

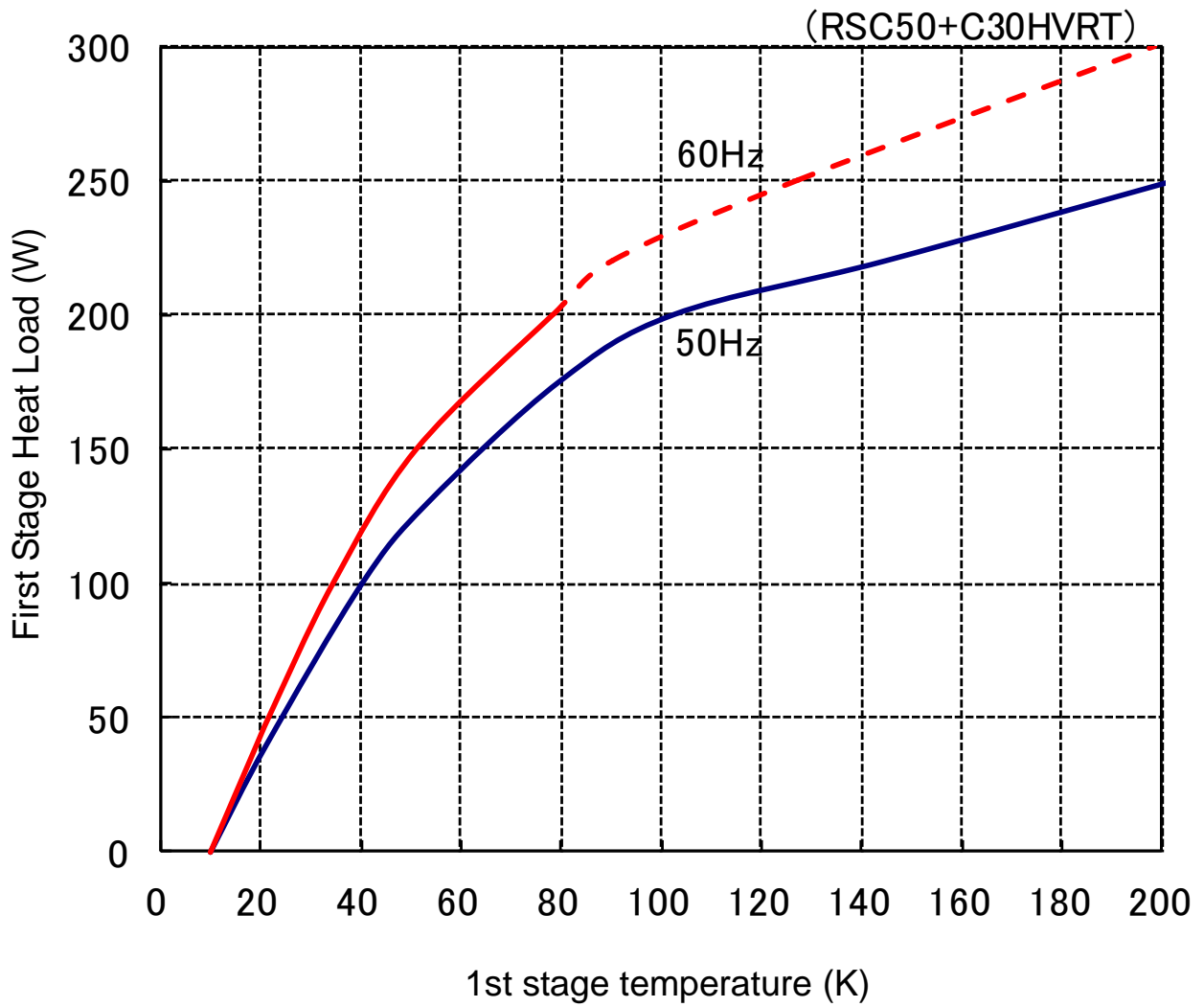

NOTE: Please contact us if you consider using the RSC50T with power frequency of 60Hz and temperature of above 77K.

---

## Appendix E

### COOLDOWN CHARACTERISTICS

(when installed in a vertical orientation with the first stage pointing down)

The performance curves of a cryocooler shown in this chapter are typical examples and these capacities are not always guaranteed.

RSC50T (C30HVRT) 50/60Hz..... E-2

**RSC50T (C30HVRT)**

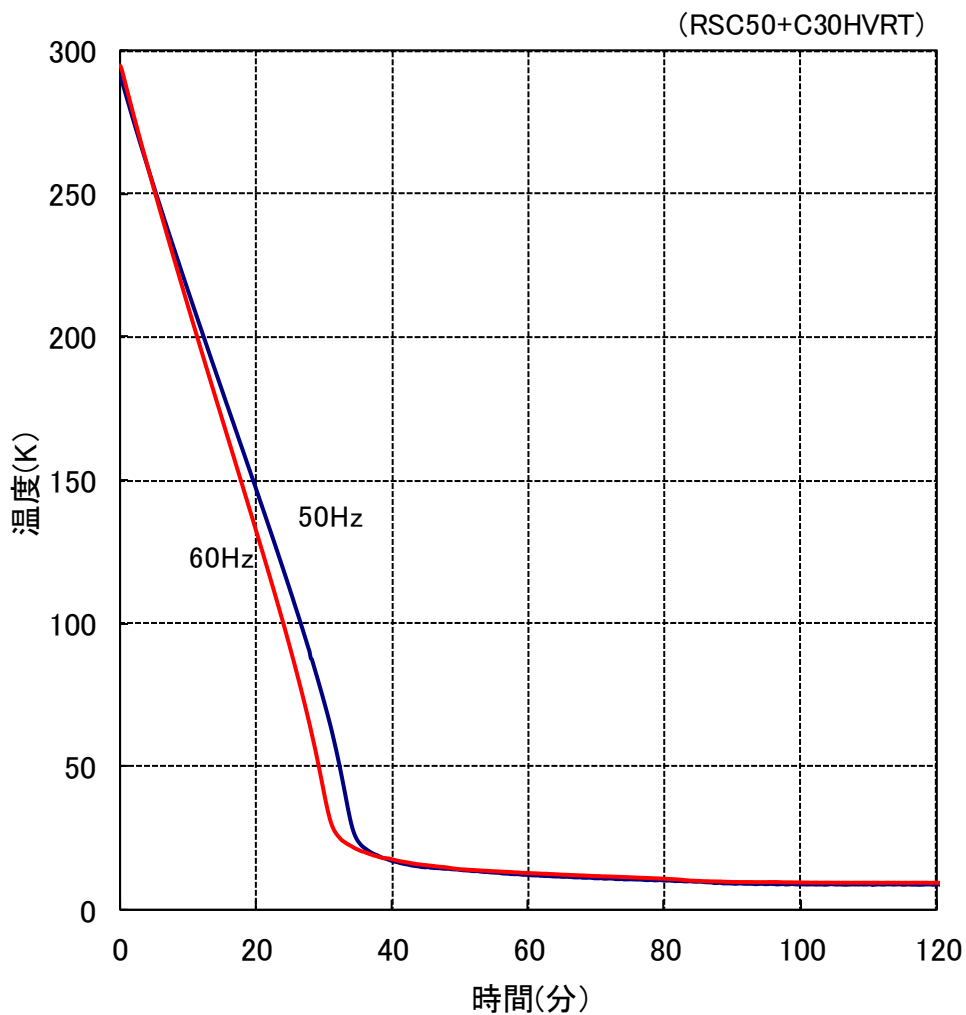

RSC50T Typical Cooldown Time (50/60Hz)



## **Appendix F**

### **DIMENSIONAL DRAWING**

1. 20K Cryocooler RSC50T.....F-2

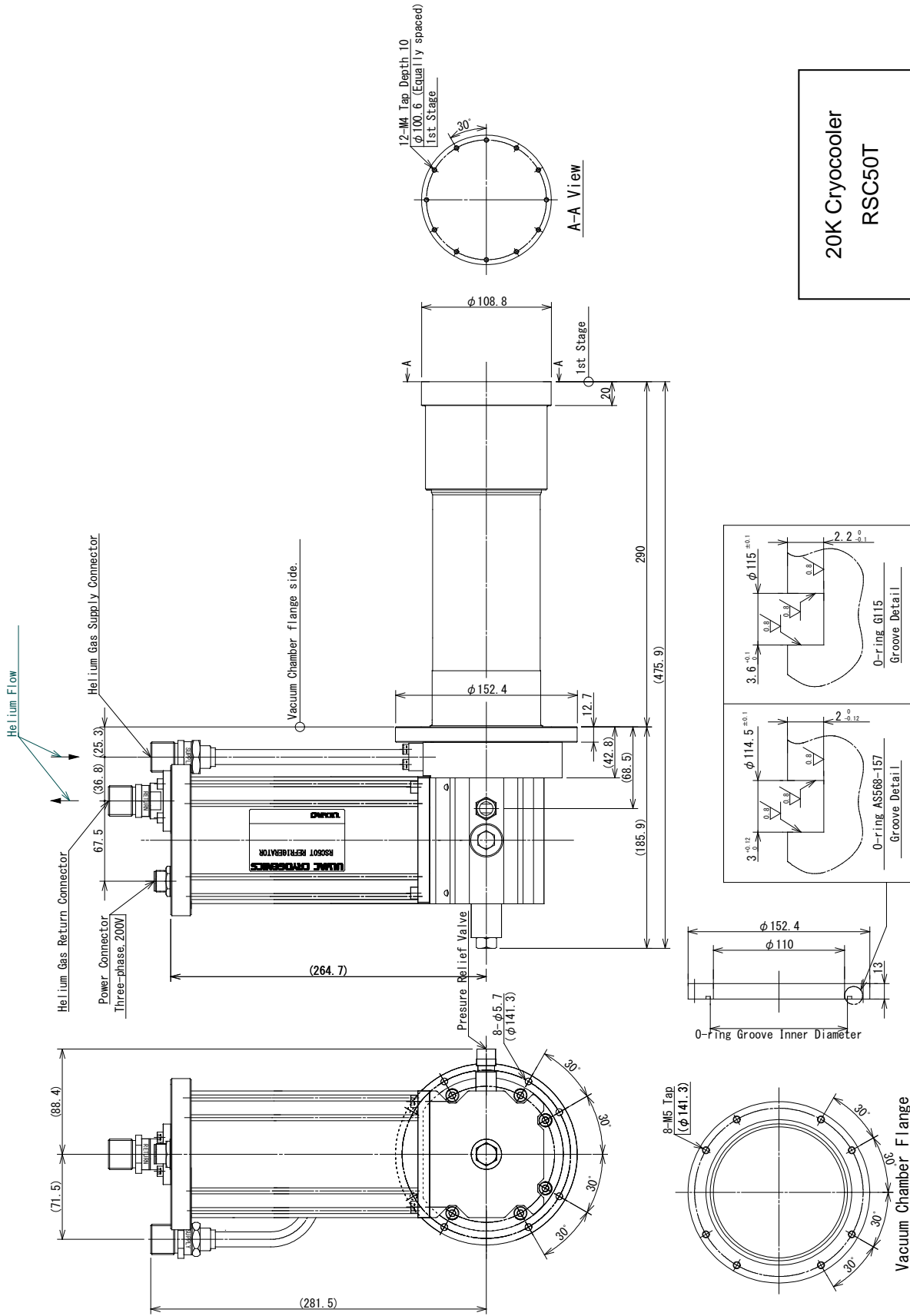

20K Cryocooler  
RSC50T

---

## SERVICE NETWORK

- For technical support, servicing or additional contact information, visit us at [www.ulvac-cryo.com](http://www.ulvac-cryo.com).

ULVAC CRYOGENICS INC.

[www.ulvac-cryo.com](http://www.ulvac-cryo.com)

1222-1 Yabata, Chigasaki, Kanagawa 253-0085, Japan

<Sales>

Tel: +81-467-85-8884

<Service Engineering Division>

Tel: +81-467-85-9366

Fax: +81-467-83-4838

ULVAC CRYOGENICS KOREA INC.

[www.ulvac-cryo.co.kr](http://www.ulvac-cryo.co.kr)

107, Hyeongoksandan-ro, Cheongbuk-Myeon, Pyeongtaek-si,  
Gyeonggi-Do, Korea, 17812

Tel: +82-31-683-2926

Fax: +82-31-683-2956

ULVAC CRYOGENICS (NINGBO) INC.

[www.ulvac-cryo.com](http://www.ulvac-cryo.com)

No.888 Tonghui Road, Jiangbei District, Ningbo, China, 315020

Tel: +86-574-879-03322

Fax: +86-574-879-10707

This page intentionally left blank.

**Revision History**

Date	Revision No.	Contents
2018-09-27	2018.09	First edition.

This page intentionally left blank.