

4K GM CRYOCOOLER

Instruction Manual

UHE10
357130121(C)

Export Control Policy

When applying a refrigerator to a cryocooler for optical sensors, the cryocooler falls under row 6.A.2.d.2 of the control list established by The Wassenaar Arrangement, which is equal to row 10(2) of appended table 1 of Japan's Export Trade Control Order.

Customers must follow all related rules and regulations such as Foreign Exchange and Foreign Trade Act and take appropriate procedures when exporting or re-exporting our refrigerators.

Introduction

Thank you for choosing our products. This instruction manual gives information and precautions on handling, installation, operation, and maintenance of the product.

This product is intended for use by qualified personnel who recognize shock hazards and are familiar with the safety precautions required to avoid possible injury. To ensure proper use of this product, read this instruction manual carefully and keep this manual close at hand so that you can use for reference during operation.

If you purchased our other products and/or optional devices with this product, read relevant instruction manuals carefully.

1. About the personnel who are involved in handling our products

All personnel involved in handling our products should take a general safety education and training that is officially accepted in the country where our product is used. The personnel are also required to have specialized knowledge/skills and qualification on the electricity, the machinery, the cargo handling, and the vacuum. Especially, the personnel should be familiar with handling a cryopump in order to use it safely. Since we offer a training session (which is subject to fees) as needed for people who use cryopumps for the first time, please do not hesitate to contact our Service Engineering Division to join the training session.

2. Warranty

2.1 Gratis warranty period and Warranty coverage

【Gratis warranty period】

Note that an installation period of less than one year after installation in your company or your customer's premises or a period of less than 18 months (counted from the date of production) after shipment from our company, which is shorter, is selected.

【Coverage】

(1) Failure diagnosis

As a general rule, diagnosis of failure should be done on site by customer.

However, ULVAC CRYOGENICS or our service network can perform this service for an agreed fee upon the customer's request. There will be no charge if the cause

of the breakdown is found to be a fault of ULVAC CRYOGENICS.

(2) Damage during transportation

When damage by delivery/transportation is admitted, the product will be repaired free of charge within the range of the guarantee expressed in the sales contract.

(3) Breakdown repairs

There will be a charge for breakdown repairs, replacements and on-site visits for the following seven conditions. In those cases the cost shall be your own expense even though the product is within the warranty period.

- ① Breakdowns due to improper storage or handling, careless accident, software or hardware design by the customer.
- ② Breakdowns due to modifications of the product without consent of the manufacturer.
- ③ Breakdowns due to maintenance of the product without authentic parts or breakdowns resulting from using the product outside the specified specifications of the product.
- ④ Breakdowns due to contamination or corrosion caused by user's use conditions.
- ⑤ Breakdowns due to natural disasters (such as fire, earthquake, flood, lightning, salt damage, and so on) , environmental pollution, irregular voltage, and /or usage of undesignated power source.
- ⑥ Breakdowns that are outside the terms of warranty.
- ⑦ Consumables and/or replacement service.

Since the above services are limited to within Japan, diagnosis of failures, etc are not performed abroad. If you desire the after service abroad, please contact ULVAC CRYOGENICS and consult us for details in advance.

2.2 Exclusion of opportunity loss from warranty liability

Regardless of the gratis warranty term, compensation to opportunity losses incurred to your company or your customers by failures of ULVAC CRYOGENICS products and compensation for damages to products other than ULVAC CRYOGENICS products and other services are not covered under warranty.

2.3 Repair period after production is discontinued

ULVAC CRYOGENICS shall accept product repairs for seven years after production of the product is discontinued.

3. Service Form

After the products are delivered, please fill out the following information in the blanks. If you have any questions or technical problems, please feel free to contact the nearest Customer Support Center or headquarters. Please refer to "Service Network".

Cryopump/Super trap Model	:	_____
Cryopump/Super trap Serial No.	:	_____
Refrigerator Model	:	_____
Refrigerator Serial No.	:	_____
Compressor Model	:	_____
Compressor Serial No.	:	_____
Temperature controller/Thermal display Model	:	_____
Temperature controller/Thermal display Serial No.	:	_____
Option Part Model	:	_____
Optional Part Serial No.	:	_____

4. Notes for repair and maintenance requests

We may decline your request for the repair or the maintenance of our products if you refuse to give us information about the presence of the hazardous substance and/or contaminant.

Also, please be aware that we do not accept liability for damages by the contaminant, which might be caused during transportation to our office or the nearest customer support center. To avoid such accident, please pay careful attention to packing of the product

5. In case of breakdown and accident

When breakdown or accident occurs, we may ask for keeping the product on site as it is or retrieving the product to investigate its cause. Also we may ask for reporting the detailed process and/or the operating condition. When unidentified malfunction was generated, please contact our Service Engineering Division or

the nearest customer support center with reference to the chapter of Service Network. We ask for cooperation about the above.

6. General Precautions

- (1) It is strictly prohibited to duplicate, open, and transfer this instruction manual or any of its parts to a third person without written permission from ULVAC CRYOGENICS.
- (2) Information in this document might be revised without a previous notice for the specification change and the improvement of the product.
- (3) If you have any questions or comments on this document, please do not hesitate to contact us. The phone numbers of local customer support centers are listed at the end of this manual.

Safety Considerations

Our products have been designed to provide extremely safe and dependable operation when properly used. Following safety precautions must be observed during normal operation and when servicing them.

**WARNING**

A warning describes safety hazards or unsafe practices which could result in severe injury or loss of life.

**CAUTION**

A caution describes safety hazards or unsafe practices which could result in personal injury or equipment damage.

**Toxic gas or chemicals used.**

There is a risk of severe injury upon contact.

**Corrosive chemicals used.**

There is a risk of severe injury upon contact.

**Flammable gas used.**

There is a danger of fire or burn injury.

**Explosive gas used.**

There is a risk of fire or explosion.

**Hazardous voltage .**

Electric shock may cause severe injury or loss of life.

**Hot heating part present.**

There is a risk of burn injury.

This page intentionally left blank

Table of Contents

Safety Instructions.....	1
Disposal Considerations	2
1. Principle and Features	3
2. Component Description.....	4
3. Cryocooler System Configuration	5
4. Specifications.....	6
4.1 Cryocooler.....	6
5. Installation.....	7
5.1 Installation.....	7
5.2 Connecting Flexible Hoses	9
6. Operation	11
6.1 Before Startup.....	11
6.2 Startup and Shutdown.....	11
7. Maintenance.....	12
7.1 Daily Inspections	12
7.2 Scheduled and Unscheduled Maintenance.....	12
7.3 Charging Helium Gas	12
8. Troubleshooting.....	15
9. Carton Contents and Accessories.....	17
9.1 Carton Contents	17
9.2 20A Flexible Hose Specifications.....	17
10. External Drawing	18

Figures

Figure 2-1	4K Cryocooler Component Description.....	4
Figure 3-1	Flow Diagram.....	5
Figure 5-1	Recommended Dimensions of Mounting Flange (O-ring).....	7
Figure 5-2	Maintenance space for a cryocooler (mm).....	9
Figure 5-3	Connecting flexible hoses.....	10
Figure 7-1	Charging Helium Gas to 4K Cryocooler System.....	13
Figure 10-1	UHE10 External Drawing.....	18

Tables

Table 7-1	Maintenance Intervals.....	12
Table 9-1	Carton Contents When Purchasing 4K Cryocooler System.....	17
Table 9-2	Carton Contents When Purchasing 4K Cryocooler Alone.....	17

Safety Instructions

This section describes safety information especially necessary when using our cryocoolers. Before using the system, read this section carefully to fully understand how to use the system properly and safely.

1. Danger of gas explosion exists. Release gas before disassembling.



The refrigerator and flexible hoses contain helium gas with the pressure of 1.5MPaG. Make sure to release gas at the time of disposal. Optional charging adopters are required to release gas.

Refrain from using the equipment in the atmosphere of corrosive gases such as chlorine.

2. Danger of explosion exists. Do not expose to corrosive gases



This system contains high pressure helium gas. Make sure to release the gas at the time of disassemble or disposal of the system or parts. There is no need to release gas for regular maintenance works. Never install the system in the atmosphere of corrosive gases such as hydrochloride or chlorine gases. When connecting flexible hoses, never twist them, and the bend radius should not be less than 250mm.

3. Danger of frostbites or burn injury exists



There are high temperature areas inside the equipment that might cause burn injury. In the coldhead where cold gas is generated, there is ultra-low temperature area that might give burn injury. Be sure to put protective wears such as leather gloves at the time of inspection during operation or disassembling for repair.

4. Danger of electric shock exists. Do not touch live parts



High voltage is applied to the power source of this system that can cause serious injuries or electrocute. It is extremely dangerous to touch uninsulated areas inside. Ensure to turn off the power supply before conducting installation, maintenance, or repair works. Ground wire must be connected to the grounding of power source breaker. (D-class grounding work is required.)

Disposal Considerations

Regulations and the ordinance concerning industrial waste treatment are provided in the country and region to discard. When disposing our products, please process abandonment according to relevant regulations and ordinance, etc.

				WARNING
<p>When it seems that the refrigerator has been used to evacuate a toxic or dangerous material, you must contact a safety supervisor before discarding, and discard it after removing the poisonous material according to directions of the safety supervisor.</p>				

We will offer Safety Data Sheet (called SDS) of our products upon your request. If you have any questions, please contact our Service Engineering Division or the nearest customer support center.

1. Principle and Features

4K GM Cryocooler

The UHE10 Cryocooler System is closed cycle refrigeration system driven by G-M cycle.

The system consists of a 4K cryocooler, a compressor and flexible hoses to connect them. Helium gas works as the refrigerant. Compressed helium gas is cooled by expansion in the coldhead, and provides ultra-low temperature of below 4 Kelvin.

2. Component Description

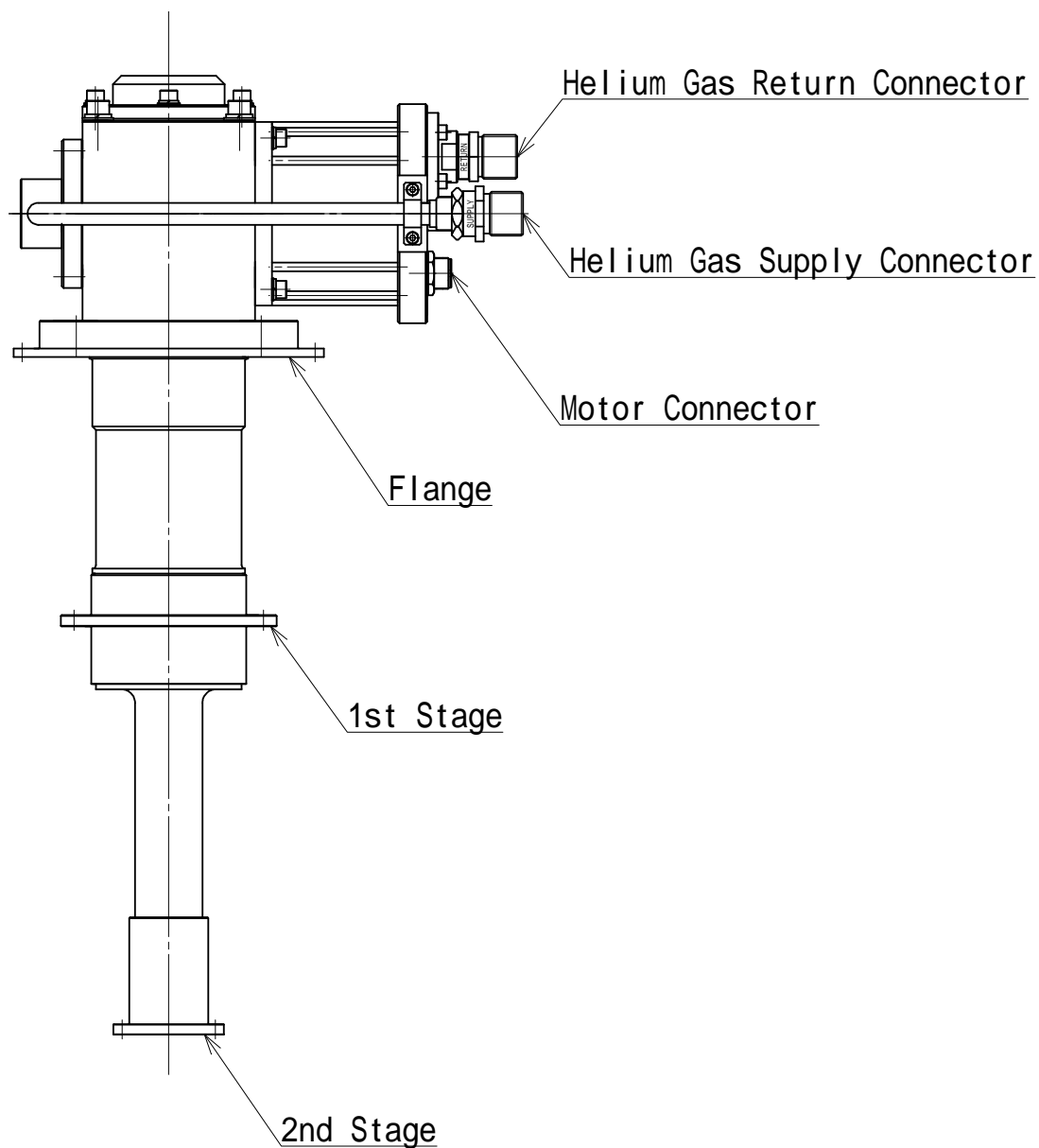

Figure 2-1 4K Cryocooler Component Description

3. Cryocooler System Configuration

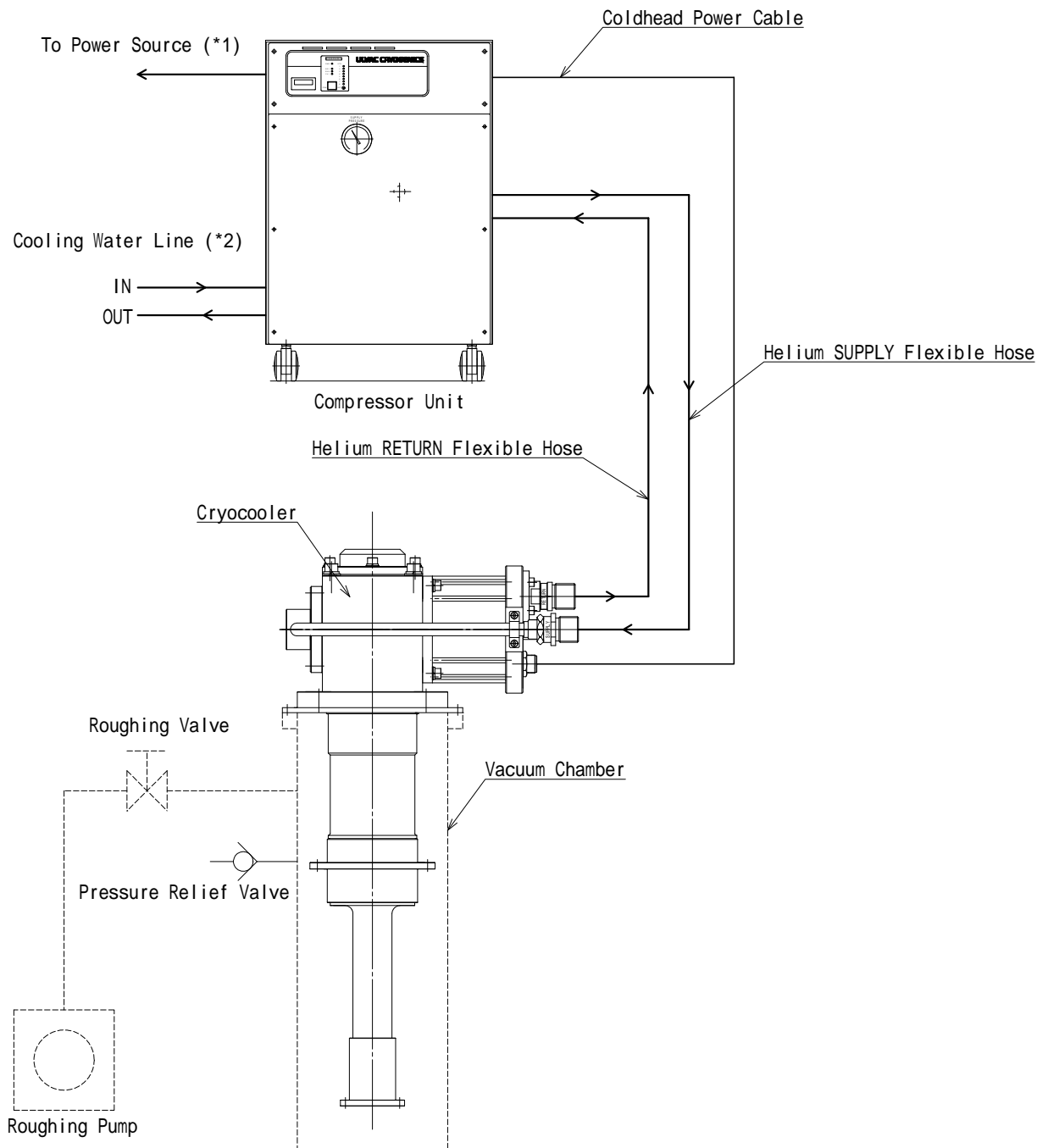

Figure 3-1 Flow Diagram

- Note 1:** Refer to the Compressor Unit Instruction Manual for the specifications of power source.
- Note 2:** Refer to the Compressor Unit Instruction Manual for the requirements for cooling water. Cooling water lines are not required for air-cooled compressors.
- Note 3:** It may be needed to connect conversion cables to coldhead cable. Refer to the Delivery Specifications.

4. Specifications

4.1 Cryocooler

Model	: UHE10
Cooling Capacity (*1)	: 2nd stage 1.0W at 4.2K 1st stage 40/50W at 43K (50/60Hz)
Ultimate Temperature (*2)	: 2nd Stage Below 2.7K
Cooldown Time (*2)	: 2nd Stage Less than 60 minutes to 4.2K
External Dimensions	: 296W x 180D x 556H
Weight	: 17kg
Ambient Conditions	: Temperature 10°C - 35°C Humidity 5% - 90% (No condensation) Allowable magnetic field Less than 500G Altitude Less than 1000m Free from metallic dust, dust, combustion gas or corrosive gas Vacuum level when using cryostats At startup Below 1Pa
Usage	: For cooling down super conducting magnet or objects placed inside an insulated vacuum chamber of a cryostat, etc.
Prohibited Use	: To Use in an environment other than the above conditions
Noise Level (1m distance)	: Maximum 65dB (The noise level may be larger depending on the ambient conditions)
Power Supply	: Three-phase, 200V, Supplied from the compressor



Note 1: These are achieved when operated with the 2nd stage pointing down. The refrigeration capacity slightly varies depending on the orientation of the coldhead.

Note 2: These are achieved when the cryocooler is in operation with no heat load. Cooldown time varies depending on the heat load of the object to be cooled, and the ultimate temperature may vary depending on incoming heat from the ambient atmosphere.

5. Installation

5.1 Installation

- 1) The system must be installed indoors, in a clean (with as few dust as possible) place.
- 2) Power source should be located close to the system.
- 3) Select a place where well ventilated and shielded from direct sunshine.

		WARNING
<p>High voltage is applied to the power source of this system that can cause serious injuries or electrocute. It is extremely dangerous to touch uninsulated areas inside. Ensure to turn off the power supply before conducting installation, maintenance, or repair works. Ground wire must be connected to the grounding of power source breaker. (The D-class grounding work is required.)</p>		

	CAUTION
<p>When the cryocooler is mounted horizontally, the object attached directly to the second stage should be lighter than 2kg. The cryocooler might not cooldown properly with an object heavier than 2kg. Please contact us if you wish to attach an object that weighs more than 2 kg directly.</p>	

Following equipments are required to use the 4K cryocooler.

- ◆ **Vacuum Chamber** : We recommend stainless-steel (or nickel-plated iron with mirror finished inner surface) vacuum chambers. The chambers should be designed to keep vacuum level of lower than 1×10^{-2} Pa in order use the cryocooler in the temperature range below 50K at the 1st stage, and below 4.2K at the 2nd stage. The pressure inside the vacuum chamber may exceed the atmospheric pressure when warming up the stages to room temperature. A pressure relief valve that works when the inner pressure is 10-20kPaG should be installed. The recommended dimensions of mounting flange of the vacuum chamber for UHE10 cryocooler are shown in the figure below.

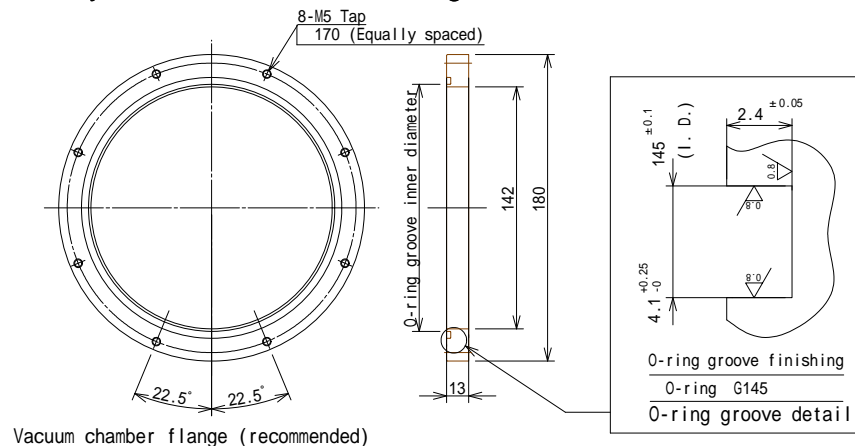

Figure 5-1 Recommended Dimensions of Mounting Flange (O-ring)

- ◆ Roughing Pump :A vacuum pump to initially rough pump a vacuum chamber. The pump need to produce vacuum lower than 1Pa to minimize the heat transfer by gases.
 - ◆ Roughing Valve :Used to isolate a vacuum chamber from roughing pump.
 - ◆ Vacuum Gauge for Roughing :Used to measure the rough pumping pressure. This gauge is required to measure from atmospheric to 1Pa.
 - ◆ High Vacuum Pump :Used as required, when outgas is large. A pump that is free from the backstream of pump oil, such as a turbo molecular pump, is recommended.
 - ◆ High Vacuum Valve :Necessary to switch pumps when using a high vacuum pump.
 - ◆ High Vacuum Gauge :Used to monitor the pressure of vacuum chamber when the 4K cryocooler is running. The gauge that works for 10^{-1} Pa to 10^{-6} Pa is needed. Ionization gauge is recommended.
 - ◆ Temperature Meter and Display :To monitor the temperature of a coldhead.
- ◇ It is recommended to install the 4K cryocooler with the cold end pointing down to maximize the refrigeration capacity although it can be installed in any orientation.
- ◇ The cryocooler system needs space for maintenance works. The space shown in figure5-2 must be cleared.

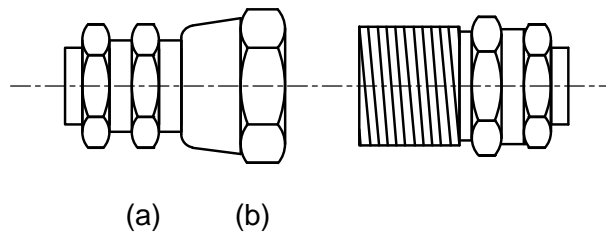

Figure 5-3 Connecting flexible hoses



CAUTION

Flexible hoses must be first connected to the compressor side and then to the cryocooler as described in the following steps 2, 3, and 4.



CAUTION

When connecting flexible hoses to the cryocooler, always connect in the order of 3 to 4 below, from the RETURN connector (labeled "RETURN"). Connecting in the reverse order may result in floating valves, leading to malfunctions.

5.2.1 Connecting the Cryocooler and the Compressor

Follow the steps below to connect flexible hoses.

- 1) Check that the connection parts are clean, and the gasket has no damage.
- 2) Connect the flexible hose to the helium connector on the compressor.

Connect the SUPPLY labeled flexible hose to helium supply connector on the compressor.

Connect the RETURN labeled flexible hose to helium return connector on the compressor.

- 3) Connect the RETURN labeled flexible hose to the RETURN connector on the cryocooler.
- 4) Connect the SUPPLY labeled flexible hose to the SUPPLY connector on the cryocooler.
- 5) Check the pressure meter on the compressor to confirm that the pressure of flexible hoses is within the range of 1.46 - 1.54 MPaG.
The helium pressure is declined when gas leaks during the connection work. Add helium gas if the pressure is lower than specified.
When the helium pressure is low although the connection is successful, there may be gas leakage in compressor unit, flexible hoses or cryocooler. Conduct the inspection for the leakage.

6. Operation

6.1 Before Startup

Check the following before starting up the cryocooler.

- 1) The power source of the compressor is correctly connected.
- 2) The cryocooler power cable and the flexible hoses are connected properly as described in 5.2.1 **Connecting the Cryocooler and the Compressor** steps 3 and 4.
- 3) The pressure of the compressor unit is within the range of 1.46 - 1.54MPaG.
- 4) The compressor cooling water flow rate is appropriate.

6.2 Startup and Shutdown

6.2.1 Startup

Turn on the compressor. Refer to the Compressor Unit Instruction Manual for the procedure. When the compressor has an operating box, refer to the Instruction Manual of the operating box as well.

The compressor unit and the cryocooler start up and refrigeration takes place.

6.2.2 Shutdown

Turn off the compressor. Refer to the Compressor Unit Instruction Manual to learn how to stop. When the compressor has a control box, refer to the corresponding Instruction Manual as well.

The compressor and cryocooler stop.

The system also stops when one or more of the alarms are activated.

Refer to the instruction manual of the compressor unit for the detail of alarms.



CAUTION

Never disconnect flexible hoses immediately after shutdown of the 4K cryocooler. This may invite hazards as helium gas of ultra low temperature inside the coldhead expands as temperature rises and the pressure inside the cryocooler sharply increases. If it is necessary to disconnect flexible hoses for purposes such as maintenance, make sure that the coldhead returns to the room temperature before disconnecting flexible hoses. In a vacuum insulated environment, it takes about 12 hours although the time may vary depending on the weight of the object to cool.

NOTE: When performing decontamination of a cryocooler, disconnect the flexible hoses on the compressor side immediately after shutdown.

7. Maintenance

7.1 Daily Inspections

Check the following conditions on a daily basis.

- 1) The working sound is normal.
- 2) The helium pressure is from 1.46MPaG to 1.54MPaG.

7.2 Scheduled and Unscheduled Maintenance

Perform scheduled and unscheduled maintenance work at the intervals in table 7-1.

Table 7-1 Maintenance Intervals

Action	Content	Maintenance Intervals
Scheduled Maintenance	Adsorber replacement	Refer to the instruction manual of the compressor unit.
	Coldhead maintenance (O-ring, seal, etc.)	Every 10,000 hours (The interval may vary depending on the operating conditions.)
Unscheduled Maintenance	Adding helium gas	When the charge pressure decreases
	Replacing other parts	At appropriate intervals
Inspections	Electrical system, Piping	Every two years

7.3 Charging Helium Gas

Charging Helium Gas to the 4K Cryocooler System

Following items and helium gas are necessary for charging helium gas.

	Item	Volume	Item code
1	Helium charging kit (Regulator, Charging hose)	1 set	-
2	<Items independently available> Regulator (for helium gas) Charging hose 2.4M	1 1	A700A5101700 A700A5101800
3	Helium gas (with purity of 99.999% or above)	-	-

Customers are requested to supply equipments such as pressure regulator or charging hose that can be used at 2.0MPaG or above.



CAUTION

If the helium pressure gauge shows 0MPaG, the air or moisture in the air may invade in the system and cause contamination. Contact us if such condition is observed.

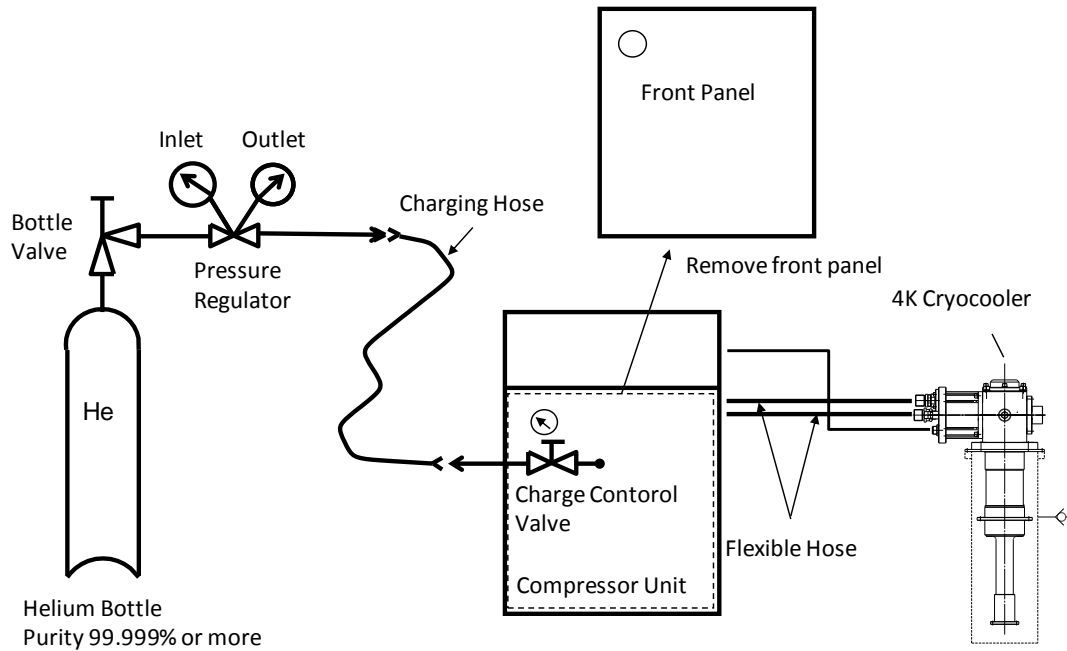

Figure 7-1 Charging Helium Gas to 4K Cryocooler System

When helium gas pressure is low, use the following procedure to charge helium gas (Refer to Figure 7-1). Before starting charging, locate the cause of pressure decrease. If there are leaks, clear the cause of the leaks and charge. Leaks are often caused by improperly connected self-sealing couplings.

- ◆ Recommended pressure regulators are with the pressure gauge on the outlet pressure of 4-6MPaG.
- ◆ Helium charge fitting is 1/4B male flare.
- ◆ Use helium gas with the purity of 99.999% or above.

Steps to charge helium gas are as follows;

1. When mounting the regulator on a new helium bottle, perform the following procedures in order to purge air and fill helium gas in the gas line between the regulator and the bottle valve.
 - (a) Open the regulator slightly, normally by turning the handle clockwise.
 - (b) Slowly open the bottle valve, and purge the regulator and line for several seconds.
 - (c) Close the pressure regulator.



CAUTION

If the bottle valve is opened without performing the procedure 1, the air between the regulator and the bottle valve diffuses into the helium bottle and lowers the purity of helium gas.

2. Remove the front panel of the compressor unit.
3. Connect the helium charging hose as follows:
 - (a) Connect the charging hose to the regulator.
 - (b) Loosely connect the charging hose to the charge inlet on the compressor unit so that helium gas can be slightly blown out here.
 - (c) Open the regulator to make the outlet pressure to be 0.1 to 0.2 MPaG. Allow helium gas to flow out from the flare fitting of the charging hose for about 30 minutes. Meanwhile, open the charging valve on the compressor unit slightly in order to drive out the air between the charge control valve and the charge port.
 - (d) Tighten the flare nut at the end of charging hose and close the charge valve. Helium line decontamination between the regulator and the charge control valve on the compressor has been completed.
4. Adjust the outlet pressure of the regulator at 1.8 MPaG. The safety valve attached to the pressure regulator should be set to 2.4MPaG.
5. Check that the compressor unit is suspended. Open the charge control valve of the compressor unit slowly and charge helium gas until it reaches to the static charge pressure.



CAUTION

If helium gas has been charged more than 1.9MPaG or more, the pressure relief valve on the cryocooler may work. Charge helium gas slowly to prevent the pressure relief valve from being activated. The pressure relief valve in the compressor unit is set to operate at 2.5MPaG.

6. Close the charge valve after charging helium gas.
7. Close the regulator and remove the charging hose from the charge inlet of the compressor unit.

8. Troubleshooting

Problem	Possible Cause	Corrective Action
Operating sound is not heard	The coldhead cable is not connected correctly	Connect the cable correctly.
	Flexible hoses are not connected.	Connect the hoses correctly.
	Flexible hose is connected from the supply connector first.	Please contact us.
	Flexible hoses are connected to the wrong connectors, SUPPLY and RETURN conversely. (If a compressor is operated with the above condition, The compressor might not operate properly even after the hoses are correctly connected again.)	Connect the hoses correctly and start again. Please contact us if the equipment does not operate normally.
	Circuit protector or fuse of compressor is blown.	Follow the instruction manual to replace these parts.
	The power source of the compressor is not connected, or connected in a wrong way.	Connect the power cable if it is not connected. The system does not start if the phase is wrong. Connect each phase correctly.
	Motor failure	Please contact us.
Operating sound is heard but the temperature does not go down.	Helium pressure decline due to helium leakage of the compressor.	Add helium gas. Refer to the Compressor Unit Instruction Manual for the procedure.
	Maintenance of the 4K cryocooler is needed.	Check the elapsed time meter of the compressor. Maintenance work is required after operating 10,000 hours. Please contact us.
	Contamination inside the system	Adsorber of the compressor need, or flexible hoses are contaminated. Please contact us.
	Ambient temperature is above 35°C and refrigeration cannot take place.	Cool down the ambient temperature to below 35°C.

Operating sound is heard but the temperature does not go down.	Initial evacuation of the vacuum chamber is not sufficient.	Check the vacuum level of the chamber. When the vacuum level is not sufficient, evacuate the refrigerator chamber. If the vacuum level is not improved, helium may leak from the chamber itself.
	Other 4K cryocooler failure	Please contact us.
Deterioration of the coldhead	Deterioration of the vacuum level of the chamber	Check the vacuum level of the chamber.
	Maintenance of the 4K cryocooler is needed	Check the elapsed time meter of the compressor. Maintenance work is required after 10,000 hours of operation. Please contact us.
	4K cryocooler failure	Please contact us.
Abnormal sound is heard	4K cryocooler failure	Please contact us.

9. Carton Contents and Accessories

9.1 Carton Contents

Table 9-1 Carton Contents When Purchasing 4K Cryocooler System

Carton	Number of Package	Content	Volume
(1)	1	4K Cryocooler	1
(2)	1	Compressor Unit	1
(3)	1	Accessories of the compressor (*1)	1 set
		Instruction Manual (this book)	1
		Compressor Unit Instruction Manual	1

(*1) Power cable, coldhead cable, remote connector, a set of wrenches, flexible hoses, conversion connectors, etc.

The content may vary according to the compressor model.

Please refer to the Compressor Unit Instruction Manual for the detail.

Table 9-2 Carton Contents When Purchasing 4K Cryocooler Alone

Carton	Number of Package	Content	Volume
(1)	1	4K Cryocooler	1
		Instruction Manual (this book)	1

9.2 20A Flexible Hose Specifications

- ◆ Gas to Transfer : Helium gas (purity of 99.999% or above)
- ◆ Maximum Working Pressure : 2.45MPaG
- ◆ Working Temperature : 0-70°C
- ◆ Material : SUS304
- ◆ Length : 10m (standard)
- ◆ Minimum Bend Radius : 250mm
- ◆ Recommended torque for connection : 20N·m
- ◆ End fitting : 1/2B self-sealing coupling

Cautions for handling



CAUTION

- ◆ When carrying flexible hose, hold around the braid support to prevent damage. Bending it forcibly at an acute angle may result in damage.
- ◆ Avoid twisting the flexible hose especially when making continuous bend connections.
- ◆ Keep away from water or salt to prevent corrosion. Do not place heavy things on the flexible hoses to prevent deforming or crushing.

10. External Drawing

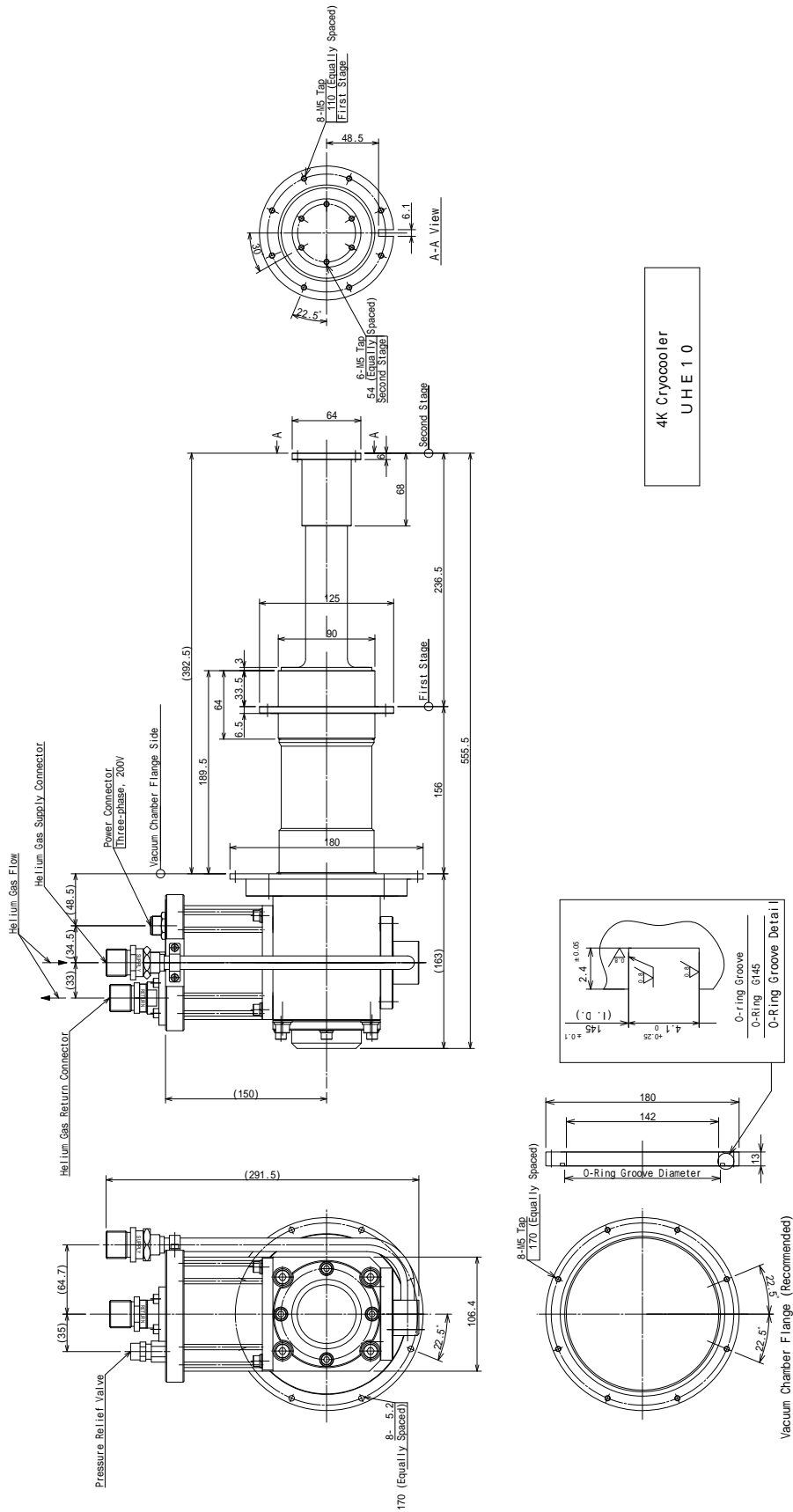

4K Cryocooler
UHE 10

Figure 10-1 UHE10 External Drawing

SERVICE NETWORK

- For technical support, servicing or additional contact information, visit us at www.ulvac-cryo.com.

ULVAC CRYOGENICS INC.

www.ulvac-cryo.com

1222-1 Yabata, Chigasaki, Kanagawa 253-0085, Japan

<Sales>

Tel: +81-467-85-8884

<Service Engineering Division>

Tel: +81-467-85-9366

Fax: +81-467-83-4838

ULVAC CRYOGENICS KOREA INC.

www.ulvac-cryo.co.kr

107, Hyeongoksandan-ro, Cheongbuk-Myeon, Pyeongtaek-si,
Gyeonggi-Do, Korea, 17812

Tel: +82-31-683-2926

Fax: +82-31-683-2956

ULVAC CRYOGENICS (NINGBO) INC.

www.ulvac-cryo.com

No.888 Tonghui Road, Jiangbei District, Ningbo, China, 315020

Tel: +86-574-879-03322

Fax: +86-574-879-10707

This page intentionally left blank.

Revision History

Date	Revision No.	Contents
2018-05-27	2018.05	First edition

This page intentionally left blank