

## Liquid Nitrogen Generator Instruction Manual

EMP-14W

### Export Control Policy

When applying a refrigerator to a cryocooler for optical sensors, the cryocooler falls under row 6.A.2.d.2 of the control list established by The Wassenaar Arrangement, which is equal to row 10(2) of appended table 1 of Japan's Export Trade Control Order.

Customers must follow all related rules and regulations such as Foreign Exchange and Foreign Trade Act and take appropriate procedures when exporting or re-exporting our refrigerators.



## Introduction

Thank you for choosing our products. This instruction manual gives information and precautions on handling, installation, operation, and maintenance of the product.

This product is intended for use by qualified personnel who recognize shock hazards and are familiar with the safety precautions required to avoid possible injury. To ensure proper use of this product, read this instruction manual carefully and keep this manual close at hand so that you can use for reference during operation.

If you purchased our other products and/or optional devices with this product, read relevant instruction manuals carefully.

### General Precautions

- (1) It is strictly prohibited to duplicate or reproduce this manual either partially or entirely, or disclose or transfer to a third party without written permission from ULVAC CRYOGENICS.
- (2) Information in this document is subject to change without notice, along with the specification change or improvement of the product.
- (3) If you have any questions or comments on this document, please contact us. The contact details are listed at the end of this book.

## Safety Conventions

Our products have been designed to provide extremely safe and dependable operation when properly used. Following safety precautions must be observed during normal operation and when servicing them.



### WARNING

A warning describes safety hazards or unsafe practices which could result in severe injury or loss of life.



### CAUTION

A caution describes safety hazards or unsafe practices which could result in personal injury or equipment damage.



Toxic gas or chemicals used.

There is a risk of severe injury upon contact.



Corrosive chemicals used.

There is a risk of severe injury upon contact.



Flammable gas used.

There is a danger of fire or burn injury.



Explosive gas used.

There is a risk of fire or explosion.



Hazardous voltage .

Electric shock may cause severe injury or loss of life.



Hot heating part present.

There is a risk of burn injury.



Low-temperature area present.

There is a risk of frostbite. Do not touch.

## Table of Contents

Safety Instructions .....	1
Disposal Considerations.....	3
1. General Description of the System .....	5
1.1 Liquid nitrogen generator (EMP-14W) .....	5
1.2 Helium gas compressor (model:SW115) .....	5
1.3 PSA (Pressure Swing Adsorption) Nitrogen Generator .....	5
1.4 Membrane Nitrogen Generator (type IM-120) .....	5
2. Component Description .....	6
2.1 Front view of EMP-14W (Figure 2-1) .....	7
2.2 Operation panel of EMP-14W (Figure 2-2) .....	7
2.3 Inside view of EMP-14W front door and lower panel .....	10
2.4 Inside the lower back panel of EMP-14W .....	10
2.5 EMP-14W Electric Circuit (Figure 2-4) .....	11
2.6 Top of the EMP-14W (Figure 2-5) .....	11
3. Flow Diagram .....	12
4. Specifications.....	13
4.1 Liquid nitrogen generator .....	13
4.2 PSA (Pressure Swing Adsorption) nitrogen gas generator .....	13
4.3 Membrane nitrogen gas generator .....	13
5. Utilities .....	14
5.1 Power source (for EMP-14W) .....	14
5.2 Power source for GN-10i (when using GN-10i) .....	14
5.3 Dry air for IM-120 (when using IM-120) .....	14
6. Installation .....	15
6.1 Conditions for installation place .....	15
6.2 Connection of GN-10i to power source .....	16
6.3 Dry air connection of IM-120 .....	16
6.4 Utility connection of EMP-14W .....	16

7. Electric Wiring.....	19
8. Operation.....	21
8.1 Checks prior to operation .....	21
8.2 Preparation for operation .....	21
8.3 Shutdown .....	22
8.4 When suspending for long time (for 1 to 2 weeks) and resuming EMP-14W .....	22
8.5 Corrective action in the event of an error .....	23
9. Dispense Liquid Nitrogen Manually.....	25
9.1 Connecting liquid nitrogen supply flexible hose .....	25
9.2 Supply of liquid nitrogen .....	25
9.3 Disconnection of the flexible hose .....	26
10. Automatic Transfer of Liquid Nitrogen .....	27
10.1 Inspections before starting automatic transfer .....	27
10.2 Automatic transfer .....	27
10.3 Time limit of automatic transfer .....	27
11. eco Mode .....	28
11.1 eco mode .....	28
12. Maintenance and Inspection .....	29
12.1 Daily inspection .....	29
12.2 Periodical maintenance/inspection .....	29
12.3 Regular customer inspection .....	30
13. Troubleshooting .....	31
14. Accessories .....	35
15. Warranty .....	36

## Safety Instructions

### 1. Danger of electric shock: Do not touch the live part.



To this unit, voltage that would cause electrocution or serious injuries is applied. It is extremely dangerous to touch the live part inside the unit. Make sure to turn OFF the main power source before performing installation, maintenance or repair. Contacting the internal parts that are not insulated may damage human body or equipments such as electrical shock.

Connect the earth wire to D type grounding.

### 2. Danger of oxygen deficiency: Ventilate well.



Nitrogen gas itself is not toxic to human bodies but it reduces the oxygen level in the atmosphere (the oxygen concentration of 18% or below is defined as an oxygen-depleted state). Choose a well-ventilated and good-air-circulated location to install the EMP-14W, and install a ventilator with a capacity of at least 1000 m<sup>3</sup>/hr airflow. In addition, do not stay together with a dewar containing liquid nitrogen in a sealed space, such as an elevator or a car.

### 3. Danger of explosion: Do not seal LN<sub>2</sub>.



The volume of nitrogen gas is 700 times of liquid nitrogen. Confining atmospheric pressure liquid nitrogen in an airtight space produces high-pressure gas as high as 700 Atm, possibly resulting in explosion. Use liquid nitrogen in the condition constantly open to air.

**4. Danger of burns or frostbites: Never touch high and ultra-low temperature area.**

Liquid nitrogen provides temperature as low as  $-196^{\circ}\text{C}$ . If liquid nitrogen is directly handled, frostbites, loss of sight, and others are foreseen. Always wear leather gloves, goggles, trousers without turnips, etc. to handle liquid nitrogen. In addition, use cautions to liquid nitrogen transport lines, too. In this unit, there is a part with danger of burns if it is touched directly.





**5. Danger of Explosion: DON'T expose to corrosive gases.**

In this unit, high-pressure Helium gas is filled. To disassemble or dispose of the unit, parts, and others, be sure to discharge gas (under regular maintenance, there is no need to discharge gas). In addition, never attempt to install the apparatus under the atmosphere of hydrochloric acid-based, chlorine gas-based, and other corrosive gases.



## Disposal Considerations

Disposal of our products must be done in accordance with applicable national and local laws and regulations.

				<b>WARNING</b>
<p>The cryocooler may contain residue of hazardous substances resulting from actual use. Contact your safety supervisor and follow the instructions to remove such toxic substances before disposing.</p>				

We provide Safety Data Sheet (SDS) of our products upon your request. Please contact us if necessary.

This page intentionally left blank.

# 1. General Description of the System

## 1.1 Liquid nitrogen generator (EMP-14W)

EMP-14W Liquid Nitrogen Generator provides liquid nitrogen by cooling down, condensing and liquefying nitrogen gas with the cold head (Model:S050).

Liquid nitrogen is stored the inside the dewar, and can be dispensed to another container with easy operation. With the optional automatic transfer system, liquid nitrogen can be automatically transferred to the dewars of customers' equipments.

Nitrogen gas source can be selected from two types; (1) PSA nitrogen generator, (2) Membrane nitrogen generator.

Liquid nitrogen generator is hereafter referred to as "EMP-14W" in this manual.

## 1.2 Helium gas compressor (model:SW115)

This unit is located on the lower part of EMP-14W, compress helium gas to supply to the cold head to provide cryogenic temperatures. It is automatically turned on and off by the control circuit of EMP-14W.

Helium gas compressor is hereafter referred to as "SW115" in this manual.

For details of this equipment, please refer to the operation manual for "SW115".

## 1.3 PSA (Pressure Swing Adsorption) Nitrogen Generator (type GN-10i)

PSA Nitrogen Generator GN-10i generates highly concentrated nitrogen from air using adsorber and supply the gas to EMP-14W. The nitrogen generated here is used as the material for liquid nitrogen and is also used to take out liquid nitrogen.

PSA nitrogen generator is hereafter called "GN-10i" in this manual. When we describe things that are in common with membrane nitrogen generators, they are collectively referred to as "nitrogen generators".

Please refer to the operation manual of GN-10i for details.

## 1.4 Membrane Nitrogen Generator (type IM-120)

Membrane Nitrogen Generator IM-120 takes in dry air from user's equipments and generates highly concentrated nitrogen with membrane separation technology. The nitrogen generated here is used as the material for liquid nitrogen and is also used to take out liquid nitrogen.

Membrane nitrogen generator is hereafter called "IM-120" in this manual. When we describe things that are in common with PSA nitrogen generators, they are collectively referred to as "nitrogen generators".

Refer to the operation manual of IM-120 for details.

## 2. Component Description

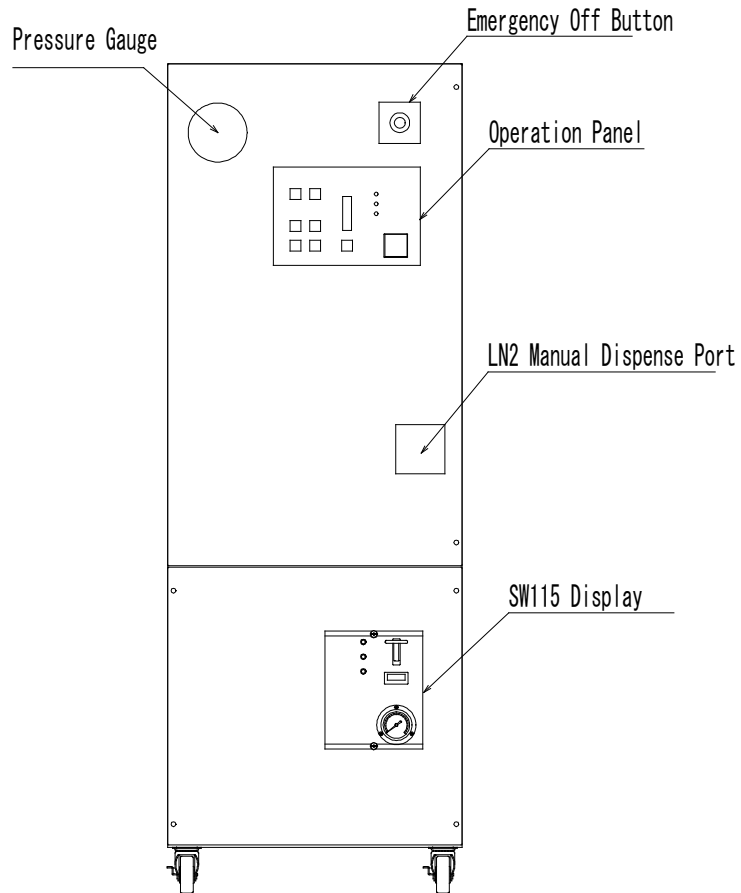

Figure 2-1 Front view of EMP-14W

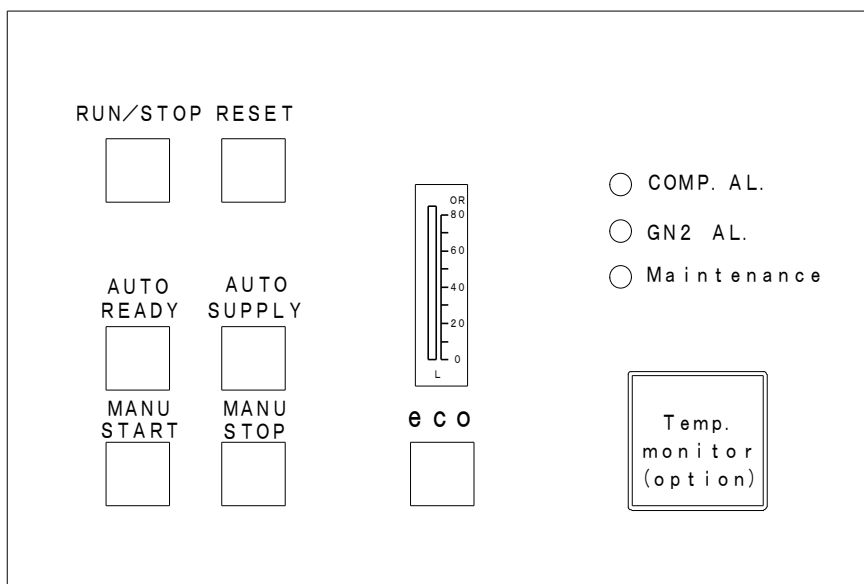

Figure 2-2 Operation panel of EMP-14W

## 2.1 Front view of EMP-14W (Figure 2-1)

Emergency off button	:Press this button to interrupt power supply to the control circuit to stop such operations as liquid nitrogen supplying, etc.
Front door	:Remove two screws to open this door. Inside the door, there are a liquid nitrogen dewar, a cold head and electric circuits. Open this door only for periodic inspection, maintenance and repair services.
LN <sub>2</sub> manual dispense port	:Press the panel to open. Inside the panel, there is a tube connector used to connect liquid nitrogen dispense flexible hose. Since the port may reach extremely low temperature, use cautions not to touch the port during or immediately after dispensing LN <sub>2</sub> .
Pressure Gauge	: The pressure gauge indicates the pressure inside the dewar.
Display of SW115	:The status of the compressor is displayed. When the alarm state is cleared at the compressor, press the <RUN/STOP> button to reset.

## 2.2 Operation panel of EMP-14W (Figure 2-2)

RUN/STOP	:Use this button to start or stop the main unit. Green light illuminates during normal operation, and flickers when the error occurs. In addition, the light will turn off when the machine is in eco-mode standby.
RESET	: This switch is used to reset the EMP-14W error state after removing the cause of a trouble.
AUTO READY	: Use this button to use the optional automatic transfer function. While turning ON this function, the EMP is in stand-by state, and automatic transfer to the set destination is possible by receiving the signal. While in stand-by state, this button lights in green. When the level sensor of the target dewar detects any trouble, green light blinks.

AUTO SUPPLY	: When you use the optional auto-transfer function with our level sensor, use this button to start transfer of liquid nitrogen at your convenience while the EMP is in standby mode for automatic transfer. This button illuminates in white while automatic transfer is taking place.
MANUAL START	: Press this button to manually dispense liquid nitrogen from LN <sub>2</sub> manual dispense port. (To be referred to as “manual dispense”) The manual dispense is terminated automatically in 10 minutes. This button lights in green while liquid nitrogen is manually supplied and starts blinking from 30 seconds before terminating automatically. When you wish to supply more, press this button again while it is blinking to extend the supply by 10 minutes..
MANUAL STOP	: Press this button to stop the manual dispense of liquid nitrogen.
Indicator	: Displays the approximate amount of liquid nitrogen in the dewar.
eco	: Press this button to switch to eco-mode operation and the button lights in blue. For eco mode, please refer to "13.eco mode".
COMP. AL.	: Red light illuminates when the SW115 is in error state. The RUN/STOP button blinks at the same time.
GN2 AL.	: Red light illuminates when nitrogen gas generator stops due to faults. The RUN/STOP switch also blinks.
Maintenance	: This light turns on when the GN-10i is approaching the maintenance interval.
Temperature meter	:This shows the temperature inside the dewar.

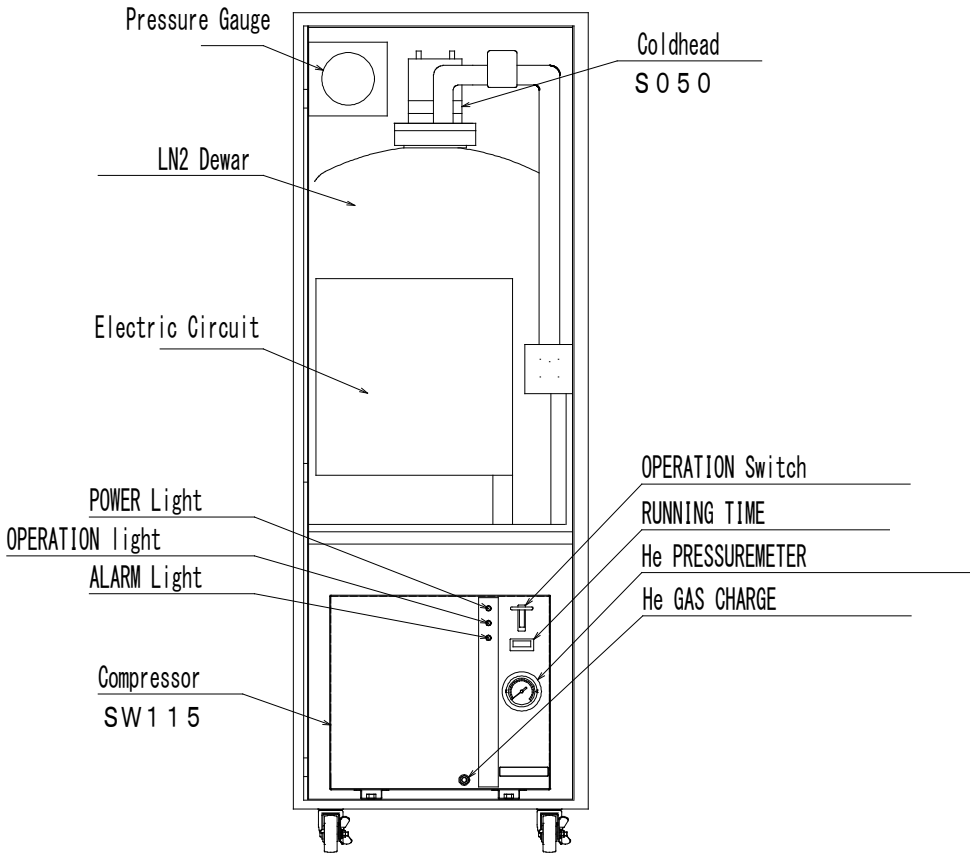

Figure 2-3 Inside view of EMP-14W front door and lower panel

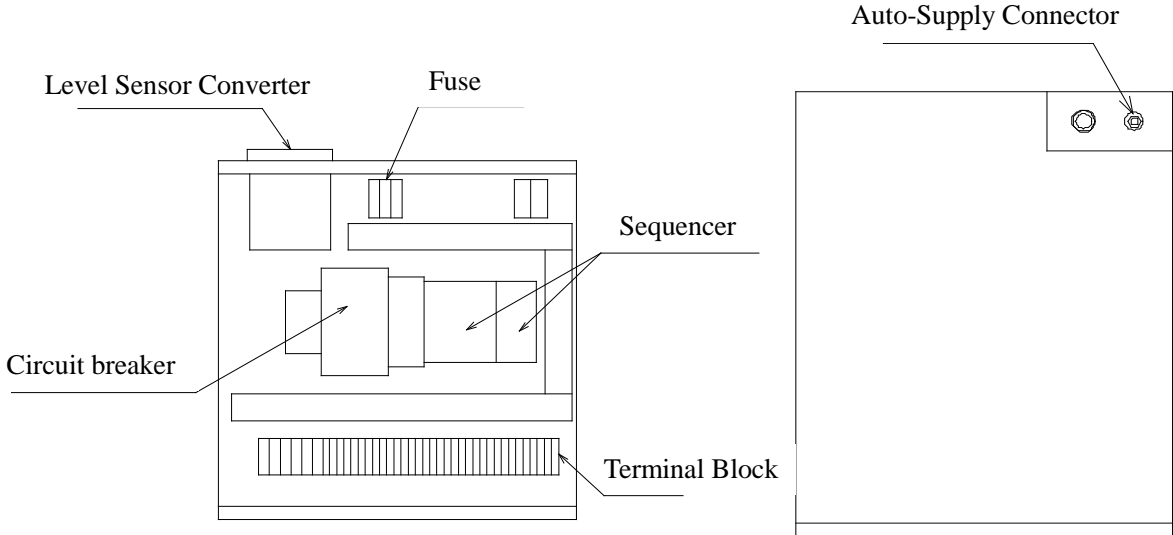

Figure 2-4 Electrical circuit

Figure 2-5 Top of EMP-14W

### 2.3 Inside view of EMP-14W front door and lower panel (Figure 2-3)

LN <sub>2</sub> Dewar	:Stores liquid nitrogen up to 40 liters.
Cold head (S050)	:The cold head works in conjunction with the compressor to generate ultra-low temperature. The cold head needs maintenance services according to the time in operation.
Pressure gauge	:Displays the pressure inside the Dewar.
He PRESSUREMETER	:Displays the helium pressure of the SW115.
He GAS CHARGE	:Use this port when charging helium gas. Do not use except when needed as it may result in helium leak.
OPERATION switch	:Use this lever to turn ON and OFF the SW115. Always keep the lever ON (pressed to the upper side). This switch can be used as the reset switch when the SW115 is in error state.
RUNNING TIME	:Displays the total operation time of the SW115. Use this information to perform maintenance work properly.

### 2.4 Inside the lower back panel of EMP-14W

L/R Switch	Use this to switch between REMOTE or LOCAL operation of SW115. When REMOTE is selected, turning ON and OFF the SW115 is done from the control circuit of the EMP-14W. When LOCAL is selected, the SW115 is turned ON and OFF with the SW115 <RUN/STOP> button. Normally, set this switch to REMOTE. If switched to LOCAL, EMP-14W cannot control the SW115.
------------	---



## 2.5 EMP-14W Electric Circuit (Figure 2-4)

Circuit breaker	: The circuit breaker protects the control circuit of EMP-14W. It is tripped when an electric leak or short-circuit occurs.
Fuse	: The EMP14W has protective fuses for AC circuit (F-1, 2: 3A) and protective fuses for DC circuit (F3: 2A).
Sequencer	: The sequencer controls the entire system. This receives the signals from the sensors and runs necessary equipments. In case the system is in error state, inform us whether the input/output light of the sequencer is turned ON (or blinking) or OFF.
Level sensor converter	: The level sensor converter is the electronic device to monitor the LN <sub>2</sub> level inside the Dewar. Do not touch the buttons as they are precisely adjusted.
Terminal Block	: The terminal block connects the signal lines between electric devices or Dewars.

## 2.6 Top of the EMP-14W (Figure 2-5)

Auto-Supply Connector (Optional)	: The Auto-supply connector is the joint (Swagelok) to connect the LN <sub>2</sub> automatic supply tube. Use cautions as it reaches to extremely low temperature during and immediately after LN <sub>2</sub> transfer.
-------------------------------------	--

### 3. Flow Diagram

This may vary depending on the customers' specifications.

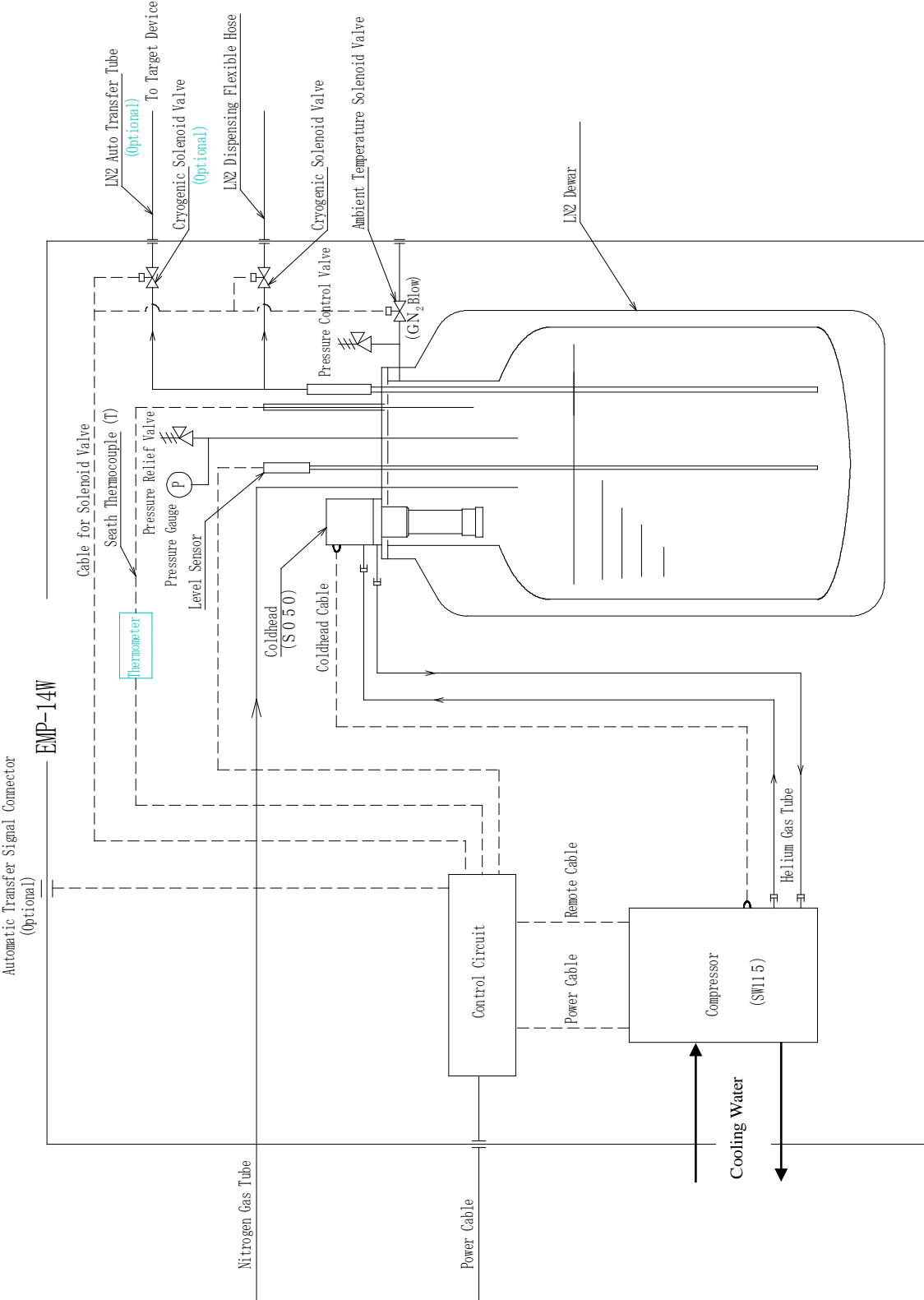

Figure 3-1 Flow Diagram

## 4. Specifications

### 4.1 Liquid nitrogen generator

Type	: EMP-14W
Amount of liquid nitrogen generated	: 14L/day (50/60Hz)
High pressure gas processing capacity	: 9.1 m <sup>3</sup> /day
Dimensions	: 600[W]*750 [D] * 1688 [H]
Weight	: Approx. 230 kg
LN2 storage capacity	: Maximum 40L
Cold head	: S050
Compressor	: SW115
Cooling method	: Water-cooled
Environment requirement	: Ambient temperature: 10 – 35°C Relative humidity: 80% or below (Non-condensation except on LN <sub>2</sub> dispense port)

- The EMP-14W must be installed indoors.

### 4.2 PSA (Pressure Swing Adsorption) nitrogen gas generator

Type	: GN-10i
Dimensions	: 400[W] ×460[D] ×900[H]
Weight	: Approx.60kg
Cooling method	: Air-cooling (Inhale from the front, exhaust from the back)

- GN-10i must be installed indoors.
- GN-10i must not be used in the atmosphere with organic solvents or corrosive gases.
- Air inhaled from the front is discharged to the backside. Do not block the front and backside.

### 4.3 Membrane nitrogen gas generator

Type	: IM-120
Dimensions	: 150[W] ×300[D] ×800[H]
Weight	: Approx.20 kg

- IM-120 must be installed indoors.
- IM-120 must not be used in the atmosphere with organic solvents or corrosive gases.

## 5. Utilities

### 5.1 Power source (for EMP-14W)

Voltage	: 200 VAC , three-phase
Power capacity	: 20A or above
Power consumption	: 1.6/1.9 kW ( 50/60 Hz )
Connection	: Round type crimping terminal for M5
Cooling water	: 4–6L/min, 5-35°C, Maximum pressure 1MPa

<NOTE> Refer to the instruction manual of the SW115 for the detailed information on the cooling water requirements.



**CAUTION**

Use Class-D earthing for safety.

### 5.2 Power source for GN-10i (when using GN-10i)

Voltage	: 100 VAC, single phase
Power capacity	: 15 A or above
Power consumption	: 400W ( 50/60 Hz )
Connection	: 3-pin outlet plug with ground wire



**CAUTION**

Use Class-D earthing for safety.

### 5.3 Dry air for IM-120 (when using IM-120)

Pressure	: 0.5MPa – 1.0MPa
Flow Rate	: 120L/min or more
Dew Point	: -17 °C or below (at the atmospheric pressure)
Air Quality	: Oil-free

**NOTE:** Use compressors equipped with a dryer.

**Supply dry air continuously.**

## 6. Installation

### 6.1 Environmental requirements

- (1) Install the equipment indoors, at a level and stabilized place. Power supply or other utilities should be located nearby.
- (2) Install the equipment at a well-ventilated place where the ambient temperature is 10 – 35°C and humidity is 80% or less (without condensation in other than cooling-water hoses).
- (3) Secure the following spaces for maintenance work.

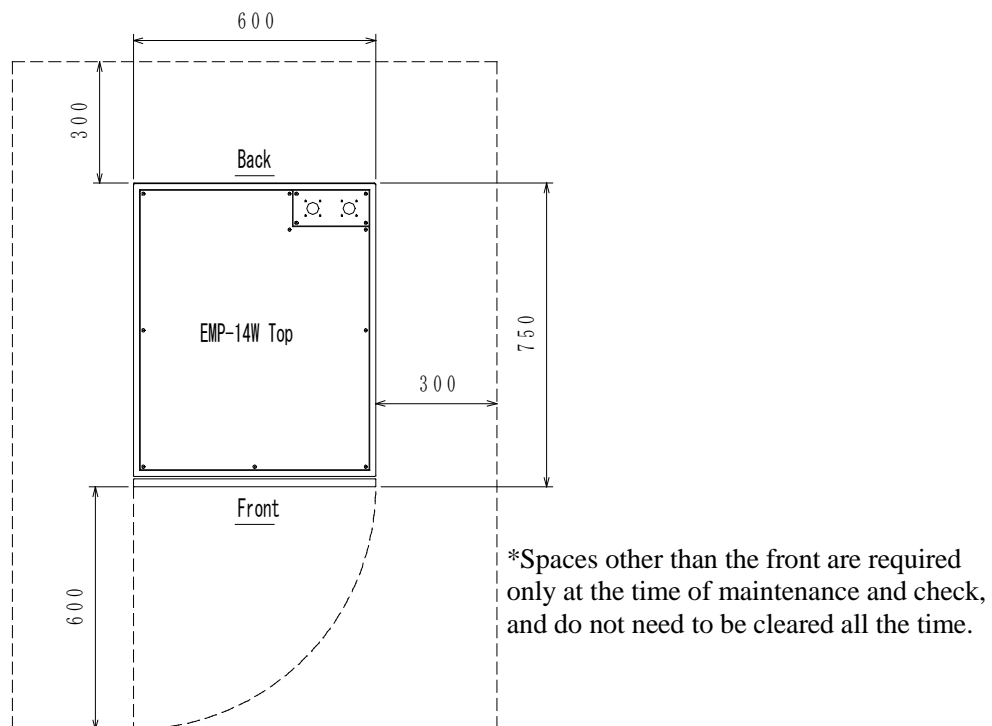

**Figure 6-1 Maintenance space for EMP-14W**

- (4) Lock the wheels to fix the equipment.

6.2 Connection of GN-10i to power source

	 <b>WARNING</b>
<p>Ensure that main power source is disconnected before making the connection to power-supply.</p>	

 <b>CAUTION</b>
<p>For safety and stable system performance, read this instruction manual and other necessary information carefully before performing maintenance work.</p>

 <b>CAUTION</b>
<p>Only the qualified personnel for electric connections who have sufficient knowledge on the structure and the risk accompanied to this equipment can perform the following works. Ignoring this caution may result in serious body injury or death.</p>

- Supply Voltage :100 VAC ± 10% (50/60Hz), Single-phase
- Power capacity :15 A or more
- Power consumption :Approx.400W (50/60 Hz )

- (1) Use a circuit tester or others to confirm that the .supply voltage is within the scope of the above.
- (2) Plug the power-supply cable which comes out from the back of GN-10i
- (3) Turn on the power breaker inside the GN-10i.

6.3 Dry air connection of IM-120

- (1) Attach the connector for tubes to the dry air valve. Screw size is R1/4.
- (2) Onto the connector attached as in the step (1), attach the tube for dry air supply. Connect the other side of the tube to "AIR IN" connector on the back side of IM-120.

6.4 Utility connection of EMP-14W

Remove the back panel of EMP-14W and locate opening for utility connection on the bottom. Connect cables of power-supply, nitrogen tube and remote cables of nitrogen gas generation system through this opening.

## 6.4.1 Power-supply connection of EMP-14W



	 <b>WARNING</b>
Ensure that main power source is disconnected before making the connection to power-supply.	

- Supply Voltage :200 VAC  $\pm$  10% (50/60Hz), Three-phase
- Power capacity :20 A or more
- Power consumption :1.6 / 1.9kW (50/60 Hz )

(1) Confirm that the power-supply voltage is within the above scope by using testers or other devices.

(2) Connect the crimping terminal side of power cables to EMP-14W through the holes on the bottom. Make sure that the marks on the terminal block (R, S, T, E) correspond to the marks of power cables, and connect them to the terminal block. If the connection is inadequate, it may result in damage by a fire while the equipment is in operation.

(3)When the connection to the terminal board is made, attach the power cable to the circuit breaker and supply electricity by turning on the breaker in the electric circuit part of EMP-14W. Be sure to confirm that the power is supplied to the sequencers or other parts in the electric circuit of EMP-14W.

	 <b>WARNING</b>
Do not connect the earth ground wire to power lines. It may result in electric shock or electric leakage.	

 <b>CAUTION</b>
When you operate multiple devices with one power source, be aware of the total capacity. Lack of capacity invites overcurrent (voltage drop) and may result in damaging the equipments.

 <b>CAUTION</b>
Only the personnel who have sufficient knowledge and skill on electric connections or cables can perform the work to extend power cables.

#### 6.4.2 Connection of Nitrogen gas tube

Place Nitrogen gas tube from the bottom hole and connect it to the gas connector of Dewar along Helium gas pipe. Connect the other side to the Nitrogen gas supply port of a Nitrogen gas generator.

#### 6.4.3 Connection of “Nitrogen gas generator” remote cable

Connect a remote cable to the remote connector inside EMP-14W and the signal connector from the back of GN-10i or “PRESSURE SWITCH OUT” connector on the back of IM-120.

Attach the back panel when all the connections have been made.



# 7. Electric Wiring

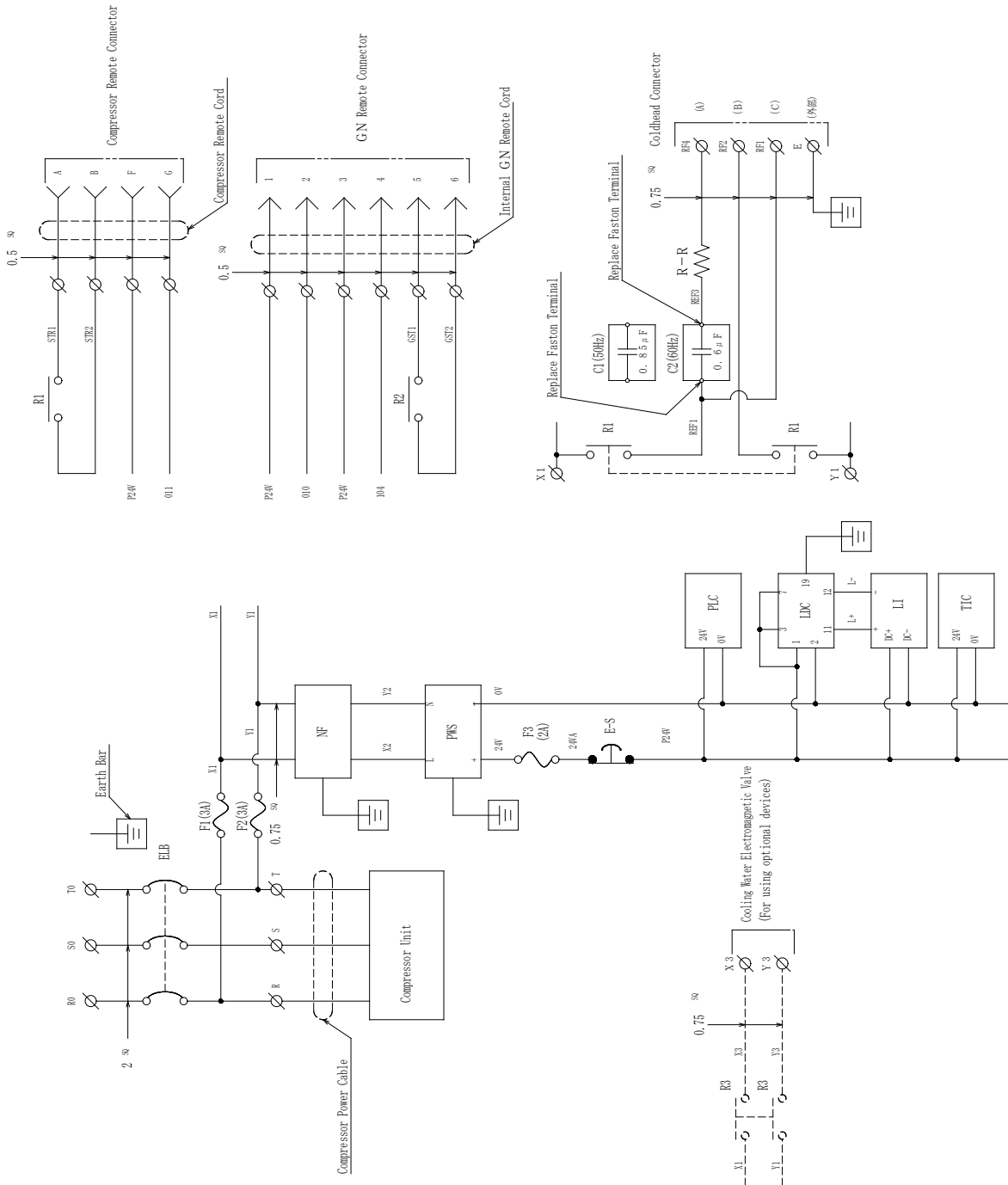

Symbol	Name
ELB	Earth Leakage Breaker
NF	Terminal Cover
PFS	Noise Filter
PLC	Power Supply
LDC	Programmable Controller
LI	Capacitance Level Meter Converter
TIC	Level Indicator
E-S	Temperature Indicator
F-1, 2, 3	Emergency Off Switch
R1	Fuse Holder
R2, (R3)	Relay
PBL1, 4	Relay
PBL2	Lighting Button
PBL3	Lighting Button
PBL5	Lighting Button
PBL1, 3	Lighting Button
PB2	Button Switch
PL1, 2	Button Switch
PL3	Indicator Light
C1	Indicator Light
C2	Condenser
C2	Condenser
R-R	Register
SV1, (SV2)	Cryogenic Electromagnetic Valve
SV3	Room Temperature Electromagnetic Valve

Figure 7-1 EMP-14W Electric wiring-1

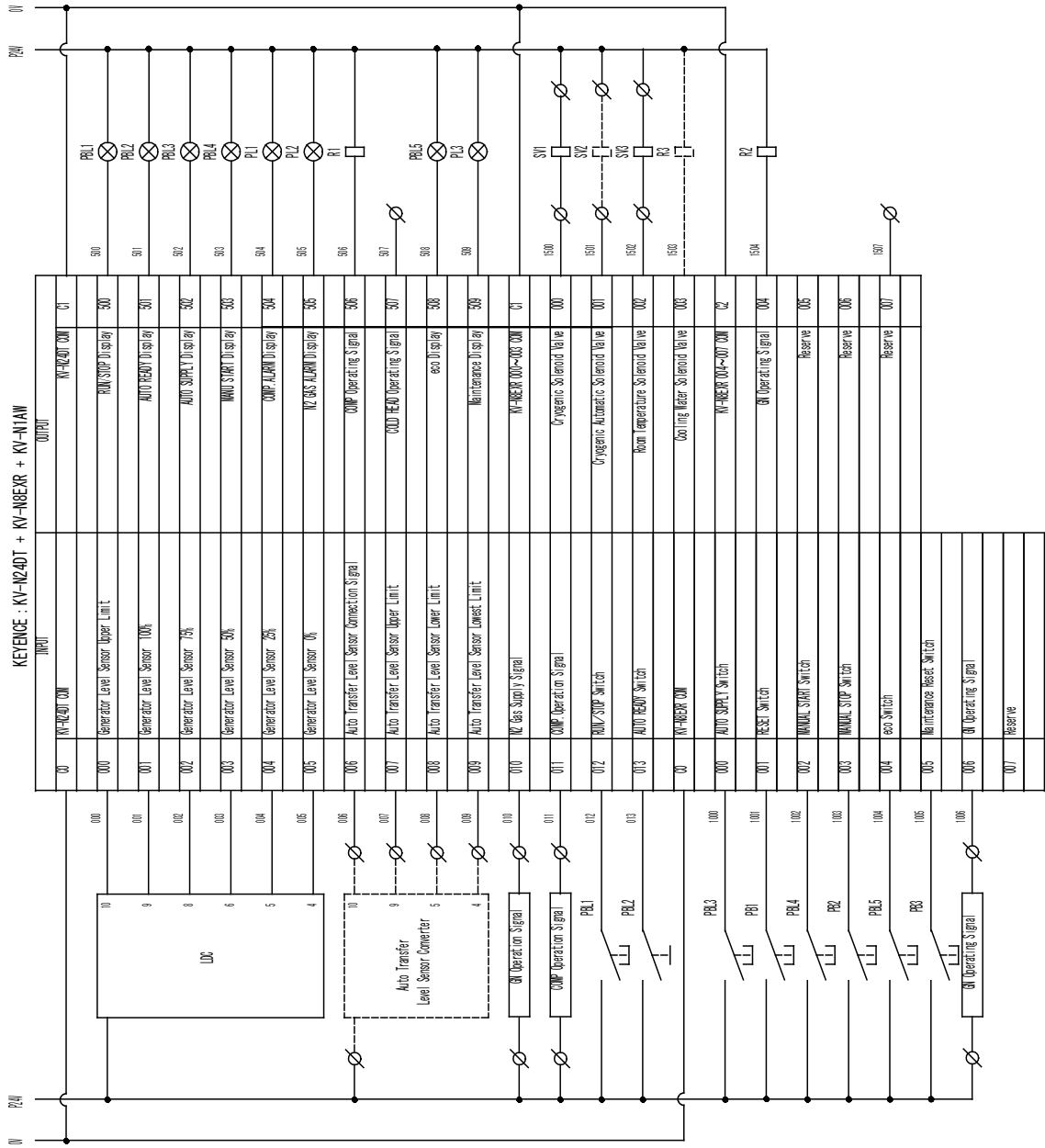

Figure 7-2 EMP-14W Electric wiring-2 (Sequencer)

## 8. Operation

### 8.1 Checks prior to operation

Check the following before starting the operation.

- (1) The power source of the EMP-14W and GN-10i is connected correctly.
- (2) The air inlet and outlet openings of EMP-14W and GN-10i are cleared.
- (3) Cooling water hose is connected properly between EMP-14W and water supply.
- (4) The nitrogen gas tube is connected properly between EMP-14W and the nitrogen generators.
- (5) The RUN/STOP switch of EMP-14W is turned off (lights off).
- (6) The main power source of EMP-14W and GN-10i are ON.
- (7) If IM-120 is used, a tube is properly connected between IM-120 and the dry air main valve
- (8) Nitrogen generator remote cables are properly connected between EMP-14W and Nitrogen generators.

### 8.2 Preparation for operation

#### 8.2.1 Start supplying nitrogen gas with GN-10i

- (1) Press RUN/STOP button of **EMP-14W** (not of GN-10i).

GN-10i starts up. When it starts operation normally, the POWER button of EMP-14W flashes with long term light-on and short term light-off.

Note: Once operation starts, RUN/STOP switch does not work for the next six minutes. If you wish to stop, press the emergency off button of EMP-14W.

- (2) 6 minutes later from the start of GN-10i, the ball in the flow meter in the front rises, and nitrogen-gas supply starts. Check that the center of the ball is in the position of 10NL/min. When shifted, refer to the operation manual of GN-10i and adjust the flow rate by control valve.

- When supplying nitrogen with type IM-120

- (1) Open the dry air valve and supply dry air to IM-120. The supply air pressure gauge "AIR INLET PRESSURE" shows dry air supply pressure.
- (2) At nitrogen gas pressure regulator, adjust the nitrogen gas pressure gauge "GN<sub>2</sub> OUTLET PRESSURE" to 0.2 MPa. Also, adjust nitrogen gas flow meter "GN<sub>2</sub> OUTLET FLOW" to 10 NL/min



### CAUTION

Use nitrogen gas with recommended flow rate and pressure. Otherwise, liquid nitrogen generation may be hindered.

### 8.2.2 Start-up

- (1) When nitrogen gas is supplied to EMP-14W, the RUN/STOP button lights in green and SW115 starts to produce liquid nitrogen.

If production does not start and the COMP.AL. illuminates, the power supply may be connected in reverse phase. In such a case, turn OFF the breakers of main power source and the electric circuit of EMP-14W, alternate two cables out of three on the main power source, and turn on the power again.

- (2) Since inside of liquid nitrogen dewar is at room temperature at the initial start-up, it is necessary to take the time to cool inside of the dewar. (It normally requires about half a day.) As the temperature inside the dewar goes down, accumulation of LN<sub>2</sub> starts. The production continues until LN<sub>2</sub> in the dewar reaches 40L (100%). After that, production starts when the amount of remaining LN<sub>2</sub> is below 30L (75%), and stops when it reaches to 40L (100%). This cycle goes on repeatedly.

### 8.3 Shutdown

When the EMP-14W is turned OFF with the RUN/STOP button, the RUN/STOP light flashes with shorter light on and longer off, and RUN/STOP button lights off and all the operations stop.

### 8.4 When suspending for long time (for 1 to 2 weeks) and resuming EMP-14W



#### CAUTION

When the system is suspended operation for a long time, liquid nitrogen in the dewar will be replaced by the air. If the device is resumed in such a condition, the liquefaction efficiency deteriorates due to the moisture in the air. Follow the procedure below when resuming.

(For GN-10i)

- (1) Take the remote cable off from GN-10i before you press the RUN/STOP switch of EMP-14W and open the front panel of GN-10i.
- (2) Turn the REMOTE/LOCAL switch to "LOCAL".
- (3) Press the button on the front side of GN-10i to startup and keep supplying nitrogen to EMP-14W for at least one hour.
- (4) Stop GN-10i, turn the REMOTE/LOCAL switch to "REMOTE", and connect the remote cables for nitrogen generators.
- (5) Press RUN/STOP button of EMP-14W to reboot the entire system.

(For IM-120)

- (1) Open the dry air valve to supply dry air to IM-120.
- (2) Supply nitrogen gas to EMP-14W for at least one hour.
- (3) Press the RUN/STOP switch of EMP-14W to reboot the entire system.

**NOTE: Please inform us in advance when the system is to be suspended for longer than two weeks.**

## 8.5 Corrective action in the event of an error

When errors occur in the equipments, please follow the procedure below and in "13.Trouble Shooting".

### 8.5.1 Corrective action when electric power failure occurs

EMP-14W and GN-10i will be automatically restored in the event of a power-failure and they will be rebooted automatically when the electricity comes back. However, when the amount of liquid nitrogen inside is 75% or more, liquid nitrogen production may not be resumed at the time of rebooting.

### 8.5.2 Corrective action when COMP. AL. occurs

- (1) Check the electric supply voltage and capacity.
- (2) Remove the transparent panel on the compressor display of the EMP-14W, press down the OPERATION switch, and the press it up.
- (3) Press RESET button of EMP-14W.
- (4) When the trouble is temporary, SW115 re-starts. When it stops due to abnormal temperature, it may be unable to re-start about 30 minutes until the temperature of a detection part falls. When SW115 does not start at all, but COMP.AL lights up again, check each part according to "14.Trouble shooting."

### 8.5.3 Corrective action when GN2 AL. occurs

(For GN-10i)

- (1) Turn off the RUN/STOP switch of EMP-14W.
- (2) Conduct reset operation of GN-10i.
- (3) Turn ON the RUN/STOP switch to re-start EMP-14W.
- (4) When Nitrogen gas begins to flow from GN-10i, GN2 AL. lights off.

(For IM-120)

- (1) Turn OFF the RUN/STOP switch of EMP-14W.
- (2) Check that the supply pressure of dry air is 0.5 MPa or above.
- (3) When the nitrogen gas pressure is 0.2MPa and flow rate is 10NL/min, turn ON the RUN/STOP switch of the EMP-14W to restart.

#### 8.5.4 Emergency off

In case of an emergency, press the Emergency Off button on the front to disconnect the control power supply and stop all the operations.







#### CAUTION

An emergency shutdown might damage the equipment. Do not use this button except in emergency.

To restart, turn the emergency off button to the right.

## 9. Dispense Liquid Nitrogen Manually

				 <b>WARNING</b>
<ul style="list-style-type: none"> <li>• When dispensing liquid nitrogen, make sure to keep the room well ventilated in order to prevent oxygen shortage.</li> <li>• Never attempt to seal liquid nitrogen.</li> <li>• When dispensing liquid nitrogen, be sure to put on protective fittings such as leather gloves. Also, use caution with handling liquid nitrogen supply flexible hose as it is in extremely low temperature right after dispensing.</li> </ul>				

### 9.1 Connecting liquid nitrogen supply flexible hose

Connect the joint (coupler joint) of attached flexible hose to LN<sub>2</sub> manual dispense port located at the front of EMP-14W. When connecting to the coupler joint, do so while pushing the outer ring part of the EMP-14W side.

### 9.2 Dispense liquid nitrogen

To manually dispense liquid nitrogen, insert the head end of flexible hose in your liquid nitrogen container, and press-and-hold the MANUAL START button for 3 seconds. With the above steps, liquid nitrogen flows out of head end of flexible hose.

The dispense operation stops automatically in 10 minutes from the start of supply. The MANUAL START button flickers 30 seconds in advance of the automatic termination. When more liquid nitrogen is needed, press MANUAL START button again to extend the operation for another 10 minutes. Press MANUAL STOP button to stop dispensing.



### CAUTION

Never leave the place while manually dispensing liquid nitrogen. Keep the place well ventilated for prevention of lack of oxygen.

- ◇ LN<sub>2</sub> production stops while dispensing manually.
- ◇ When nitrogen-gas supply stops, liquid nitrogen cannot be dispensed.
- ◇ When the automatic supply is selected (when the AUTO READY is turned on), manual dispense is limited to 25%. Also, you cannot manually dispense liquid nitrogen while automatic transfer is taking place. Manual dispense can be started after the automatic transfer finishes.

## 9.3 Disconnection of the flexible hose





**CAUTION**

When disconnecting flexible hoses, make sure that they return to room temperature. Note that disconnecting hoses right after dispensing liquid nitrogen may result in damaging the O-ring inside the coupler joint.

Disconnect flexible hoses in the opposite procedure to connecting. Push down the outer ring of the joint on the side of EMP-14W and pull out the flexible hose to disconnect.



## 10. Automatic Transfer of Liquid Nitrogen

					WARNING
<ul style="list-style-type: none"> <li>• While liquid nitrogen is being dispensed, be sure to ventilate the room to prevent a decrease in oxygen levels.</li> <li>• Never seal liquid nitrogen in the target devices.</li> <li>• Liquid nitrogen supply pipes reach extremely low temperature during and right after the supply. Caution is also advised for the extremely cold gas released from the nitrogen gas release port in the target container.</li> </ul>					

### 10.1 Inspections before starting automatic transfer

Before starting automatic supply, make sure of the following:

- (1) The level indicator cable is correctly connected between EMP-14W and the level sensor of the target device.
- (2) Liquid nitrogen supply tube is correctly connected between EMP-14W and the container of the target device.
- (3) The nitrogen gas exhaust port of the target device is open to the atmosphere.

### 10.2 Automatic transfer

(1) Turn ON the EMP-14W AUTO READY (Standby mode).

(2) Automatic transfer will start when the level sensor of the target device detects the LN<sub>2</sub> level is 25% or lower. If our level sensor is used, Automatic transfer can be started forcibly by pressing AUTO SUPPLY button.

AUTO SUPPLY button lights up in white while automatic transfer is taking place.

(3) When the level sensor of the target device detects the LN<sub>2</sub> level reaches 100%, automatic transfer will be terminated. Automatic transfer will also be terminated when the RUN/STOP or AUTO READY of EMP-14W are turned OFF, the LN<sub>2</sub> level of EMP-14W is 0%, or supply of nitrogen gas stops.

- ◇ Liquid nitrogen cannot be dispensed manually during automatic transfer.
- ◇ When the device is in standby mode by pressing AUTO READY button, manual dispense of liquid nitrogen will be limited to 25%.

### 10.3 Time limit of automatic transfer

Automatic transfer is suspended when the fixed time (defaulted to 10 minutes) passes from the start and the AUTO READY and the AUTO SUPPLY blink alternately. Blinking will stop by pressing the AUTO READY button. Check the amount of liquid nitrogen of the target dewar, and contact us when any abnormal conditions are found. Please refer to the “Service Network” at the end of this manual for the contact detail.

## 11. eco Mode

### 11.1 ECO mode

The operation of EMP-14W will be turned to eco mode by pressing “eco” button in the operation panel. EMP-14W is operated as follows in eco mode.

- ◇ When EMP-14W does not receive any requests of LN<sub>2</sub> production or the automatic transfer, it operates the nitrogen gas generator in a cycle of suspending for 22 hours and running for two hours.
- ◇ When the signal to request automatic transfer is input during eco mode, EMP-14W will start automatic transfer to the target device six minutes later than signal input.
- ◇ Manual dispense is not available during eco mode. To dispense manually, reset the eco mode and wait for 6 minutes until the nitrogen gas generator resumes operation.
- ◇ When the liquid nitrogen level of EMP-14W goes down to 30L (75%) or less, it resumes LN<sub>2</sub> production automatically. Ten minutes later from the time liquid nitrogen level reaches to 40L (100%), EMP-14W returns to eco mode.



### CAUTION

When resumed after long-term suspension or newly purchased, do not turn to “eco” mode as it may result in failure.

Set to eco mode after operating continuously for 2 weeks to 1 month. When the suspended term is about 6 months, operate 2 weeks. If it has been suspended longer, operate 1 month before setting to eco mode.

## 12. Maintenance and Inspection

### 12.1 Daily inspection

Check for the following items for daily inspection.

- (1) The operation sound generated from each unit is normal.
- (2) The pressure and flow rate of nitrogen gas are 0.2 MPa and 10 NL/min. respectively.
- (3) The He gas pressure of SW115 is within the appropriate range.

When suspended: 1.95 – 2.05 MPa

When in operation: 2.10 – 2.30 MPa

- (4) The alarm light of EMP-14W is not lit.

### 12.2 Periodical maintenance/inspection

#### (1) EMP-14W

Parts	10,000 hours	30,000 hours	40,000 hours
Coldhead Cylinder *1	✓		
Oil adsorber		✓	
Helium tube joint			✓

◇ Check the total operation time of EMP-14W with the hour meter on SW115.

\*1... Maintenance parts are normally to be replaced “Once every 10,000 hours of operation”, however, even if 10,000 hours is not reached, replace them with new ones once every 5 years as the internal parts may become deteriorated.

#### (2) GN-10i

	8,000hours or 2 years (Shorter)	20,000 hours *3
GN-10i Air Compressor	✓	
GN-10i Filter *2	✓	
GN-10i Solenoid valve		✓

◇ Check the total operation time of the GN-10i shown in the sequencer display in the electric circuit of EMP-14W. In addition, the GN-10i operation light flashes when the maintenance interval approaches,



\*2...Clean the GN-10i air-intake filter every month.

\*3... Maintenance intervals vary according to the operating conditions. As an example, in the case of use by consecutive running, it replaces them with new ones every two years.

(3) IM-120

Parts	1year	2years	5years
IM-120 Membrane			✓
IM-120 Prefilter	✓		
IM-120 tube, joint		✓	
IM-120 Fixed throttle valve		✓	
IM-120 Check Valve		✓	

	 <b>WARNING</b>
Be sure to turn off the main power source before performing the maintenance work.	

	 <b>WARNING</b>
Since helium is filled in this equipment as well as in the maintenance parts (cold head, oil adsorber), do not disassemble these parts. When you have to disassemble or dispose such parts, discharge helium using the optional charging adapter kit.	

### 12.3 Regular customer inspection

The EMP-14W is a high pressure manufacturing equipment. Please follow the applicable laws or regulations when operating and maintaining this equipment.

### 13. Troubleshooting

When any failure or unusual phenomenon occurs in the equipment, execute at first the fault diagnosis shown in the following table. When making contact with or making an inquiry to us, please check the lighting status of PLC lamp arranged to the electrical circuit in advance.

			<b>WARNING</b>
<p>Ensure that main power is disconnected before inspecting the power source or inside of the equipment. Some parts of the equipment may remain in high temperature right after stopping operation. Use caution to avoid burn injury.</p>			

Problem	Possible Cause	Corrective Action
(1) Equipment fails to start even if the RUN/STOP switch is turned on (The RUN/STOP switch lamp fails to come on.)	The main power source (breaker) is turned OFF.	Turn ON the main power source.
	The power cord is not connected.	Connect the power cord correctly.
	The circuit breaker of EMP-14W is turned OFF.	Turn ON the circuit breaker.
	The fuse of electrical circuit of EMP-14W is blown.	Replace the fuse with a new one. If the fuse is blown repeatedly, please contact us.
	The emergency stop button is pressed.	Reset the emergency stop switch by turning it in direction of arrow, and close the power source again.
(2) Equipment fails to start even if the RUN/STOP switch lights up.	The remaining LN <sub>2</sub> level is not decreased down to the re-starting level.	When the remaining LN <sub>2</sub> is decreased to 75% or less, the liquefaction starts automatically.
(3) Power breaker is tripped.	Short-circuit or electric leakages occur.	Please contact us.
(4) GN2 AL. lights on. The RUN/STOP lamp flickers at the same time.	GN-10i is suspended.	Check the electric wiring of GN-10i, or Suspend and resume EMP and GN-10i.
	IM-120 is suspended.	Check the dry air supply pressure.
	Nitrogen gas supply decreases, or the pressure is lowered temporarily.	Refer to “8-5-3. Corrective action when GN2 AL. occurs” and restart EMP-14W.

Problem	Possible Cause	Corrective Action
(5) COMP.AL lights on, and the liquefaction does not start. (RUN/STOP button starts to blink.)	The voltage is lowered and power supply fell short as multiple devices run simultaneously with one power source.	Engage one power source per one device. Fix the power supply to meet the specified value when it is not sufficient.
	Cooling water supply is not sufficient, or water temperature is too high.	Keep the appropriate cooling water conditions (water flow rate of 4-6L/min, 5-35°C)
	Electric parts of SW115 break down.	Please contact us.
	Helium charge pressure of SW115 is lower than specified.	Charge helium gas to the appropriate pressure of SW115. Contact us for more information on charging.
(6) RUN/STOP blinks and EMP does not start LN <sub>2</sub> production (Alarm light is not lit).	Less than 6 minutes have passed since RUN/STOP switch is pressed.	Wait for 6 minutes until GN2 is filled from GN-10i.
	Level sensor of EMP-14W is damaged.	Please contact us.
(7) Liquid Nitrogen cannot be dispensed.	No liquid nitrogen such as at the time of initial start-up. (LN <sub>2</sub> amount is displayed as 0 %)	Please wait until liquid nitrogen is accumulated.
	Level sensor malfunctions due to ice or frost in the dewar.	Please contact us..
	Solenoid valve breaks down (Solenoid valve does not sound operating.)	Please contact us.
	AUTO READY is turned OFF (When LN <sub>2</sub> cannot be supplied automatically.)	Turn ON the AUTO READY switch.
	eco mode is ON. (When LN <sub>2</sub> cannot be dispensed manually.)	Cancel eco mode and wait for 6 minutes.

Problem	Possible Cause	Corrective Action
(8) Liquid Nitrogen does not increase.	The equipment is in initial start-up.	Wait for about 12 hours until the dewar temperature is lowered enough to store liquid nitrogen.
	The helium gas piping and refrigerator cables are not connected correctly.	Connect the helium gas lines and refrigerator cables correctly.
	The level sensor fails to detect correctly.	Please contact us.
(9) The rate of Liquid Nitrogen production has reduced.	Cold head and oil adsorber exceed the recommended maintenance interval.	Conduct the maintenance according to the operation time.
	Helium charge pressure of SW115 is lowered.	Add helium to the specified pressure. Please contact us when this trouble occurs frequently.
	Amount of evaporation from dewar increased.	Please contact us.
	EMP absorbs special gas such as helium.	Please contact us.
	Ice or frost adheres to inside the dewar or around the cold head.	Please contact us.
	The purity of Nitrogen gas is not sufficient.	Check the purity of nitrogen gas supplied.
(10) AUTO READY button blinks.	The level sensor cable of the target device is disconnected or not connected.	Check the level sensor cable of the target device.
	The level sensor of the target device breaks down.	Please contact us.
(11) MANU START button blinks.	Only 30 seconds left until the time limit of 10 minutes of manual dispense.	Press MANU START button again to continue dispensing manually.

---

Problem	Possible Cause	Corrective Action
(12) AUTO READY button and AUTO SUPPLY button blink alternately.	The level sensor of the target device continues sending the signal to supply although the time limit of automatic supply is over.	Press AUTO READY button to cancel automatic supply mode and check the amount of liquid nitrogen in the target device. Please contact us if any problem is found.
(13) Other failures		Please contact us.



## 14. Accessories

The accessories below are delivered along with the equipments.

### EMP-14W

Flexible Hose for Dispensing LN <sub>2</sub>	1 (0.8m)
Cooling Water Hose	2 (5m)
Cooling Water Coupling	2 (Screw size R1/2)
Nitrogen Gas Tube	1 (5m)
Single Head Wrench	2 (25A x 1, 30A x 1)
Glass Fuse	3 (3A x 2, 2A x 1)
Instruction Manual	1 (This book)

### GN-10i

Remote Cable for Nitrogen Generator	1 (5m)
Instruction Manual	1

### IM-120

Remote Cable for Nitrogen Generator	1 (5m)
Connector for Tubes	1 (Screw size: R1/4)
Dry Air Supply Tube	1 (5m)
Instruction Manual	1

- The above accessories may be changed according to the directions by customers.

## 15. Warranty

### 1. Gratis warranty period and warranty coverage

#### **Gratis warranty period**

Gratis warranty period is one year starting from the date of delivery.

#### **Coverage**

##### (1) Failure diagnosis

As a general rule, diagnosis of failure should be done on site by customer.

However, ULVAC CRYOGENICS or our service network can perform this service for an agreed fee upon the customer's request. There will be no charge if the cause of the breakdown is found to be a fault of ULVAC CRYOGENICS.

##### (2) Damage during transportation

When damage by delivery/transportation is admitted, the product will be repaired free of charge within the range of the guarantee expressed in the sales contract.

##### (3) Breakdown repairs

There will be a charge for breakdown repairs, replacements and on-site visits for the following seven conditions. In those cases the cost shall be your own expense even though the product is within the warranty period.

- 1) Breakdowns due to improper storage or handling, careless accident, software or hardware design by the customer.
- 2) Breakdowns due to modifications of the product without consent of the manufacturer.
- 3) Breakdowns due to maintenance of the product without authentic parts or breakdowns resulting from using the product outside the specified specifications of the product.
- 4) Breakdowns due to contamination or corrosion caused by user's use conditions.
- 5) Breakdowns due to natural disasters (such as fire, earthquake, flood, lightning, salt damage, and so on), environmental pollution, irregular voltage, and /or usage of undesignated power source.
- 6) Breakdowns that are outside the terms of warranty.
- 7) Consumables and/or replacement service.

Since the above services are limited to within Japan, diagnosis of failures, etc are not performed abroad. If you desire the after service abroad, please contact ULVAC CRYOGENICS and consult us for details in advance.

## 2. Exclusion of opportunity loss from warranty liability

Regardless of the gratis warranty term, compensation to opportunity losses incurred to your company or your customers by failures of ULVAC CRYOGENICS products and compensation for damages to products other than ULVAC CRYOGENICS products and other services are not covered under warranty.

## 3. Repair period after production is discontinued

ULVAC CRYOGENICS shall accept product repairs for seven years after production of the product is discontinued.

**Manufacturer:      ULVAC CRYOGENICS INCORPORATED**

Please refer to the SERVICE NETWORK at the end of this book for our contact information.

This page intentionally left blank.

---

## SERVICE NETWORK

- For technical support, servicing or additional contact information, visit us at [www.ulvac-cryo.com](http://www.ulvac-cryo.com).

ULVAC CRYOGENICS INC.

[www.ulvac-cryo.com](http://www.ulvac-cryo.com)

1222-1 Yabata, Chigasaki, Kanagawa 253-0085, Japan

<Sales>

Tel: +81-467-85-8884

<Service Engineering Division>

Tel: +81-467-85-9366

Fax: +81-467-83-4838

ULVAC CRYOGENICS KOREA INC.

[www.ulvac-cryo.co.kr](http://www.ulvac-cryo.co.kr)

107, Hyeongoksandan-ro, Cheongbuk-Myeon, Pyeongtaek-si,  
Gyeonggi-Do, Korea, 17812

Tel: +82-31-683-2926

Fax: +82-31-683-2956

ULVAC CRYOGENICS (NINGBO) INC.

[www.ulvac-cryo.com](http://www.ulvac-cryo.com)

No.888 Tonghui Road, Jiangbei District, Ningbo, China, 315020

Tel: +86-574-879-03322

Fax: +86-574-879-10707

This page intentionally left blank.

**Revision History**

Date	Revision No.	Contents
2019 / 1 / 15	2019.01	First edition

This page intentionally left blank.